

AHRI 1230-2023 (I-P)

**2023 Standard for
Performance Rating of Variable
Refrigerant Flow (VRF)
Multi-split Air-conditioning and
Heat Pump Equipment**



we make life better®

2311 Wilson Boulevard, Suite 400
Arlington, VA 22201, USA
www.ahrinet.org
PH 703.524.8800
FX 703.562.1942



©Copyright 2023, by Air-Conditioning, Heating, and Refrigeration Institute
Registered United States Patent and Trademark Office
Printed in USA

**IMPORTANT
SAFETY DISCLAIMER**

AHRI does not set safety standards and does not certify or guarantee the safety of any products, components or systems designed, tested, rated, installed, or operated in accordance with this standard/guideline. It is strongly recommended that products be designed, constructed, assembled, installed, and operated in accordance with nationally recognized safety standards and code requirements appropriate for products covered by this standard/guideline.

AHRI uses its best efforts to develop standards/guidelines employing state-of-the-art and accepted industry practices. AHRI does not certify or guarantee that any tests conducted under its standards/guidelines will be non-hazardous or free from risk.

ICS codes: 23.120, 27.080

Note:

This standard supersedes AHRI Standard 1230-2021 (I-P).

AHRI CERTIFICATION PROGRAM DISCLAIMER

AHRI Standards are developed independently of AHRI Certification activities and can have scopes that include products that are not part of the AHRI Certification Program. The scope of the applicable AHRI Certification Program can be found on AHRI's website at www.ahrinet.org.

Foreword

Major changes made from the previous version, AHRI Standard 1230-2021 (I-P), are as follows

- Updates to definitions including the addition of Dessicant Dehumidification Components, Economizers, Fresh Air Dampers, Hail Guards, and Low Ambient Cooling Dampers.
- Expansion of Appendix C to add more information regarding CVP testing
- Updates to include Example piping size for Table D2
- Changes to Appendix E to clarify the changes needed for VRF testing
- Format changes to align with latest style guide.

TABLE OF CONTENTS

SECTION	PAGE
Section 1. Purpose.....	1
Section 2. Scope.....	1
Section 3. Definitions.....	1
Section 4. Classifications	9
Section 5. Test Requirements	9
Section 6. Rating Requirements.....	15
Section 7. Determination of Published Ratings.....	27
Section 8. Operating Requirements	28
Section 9. Marking and Nameplate Data	34
Section 10. Conformance Conditions	34
Section 11. Calculations.....	35
Section 12. Symbols, Subscripts, and Superscripts	36
Section 13. Minimum Data Requirements for Published Ratings	38
Section 14. Verification Testing Acceptance Criteria	38

TABLES

Table 1. Classification of VRF Systems.....	9
Table 2. Tolerances for Head Pressure Control Time Average Test	12
Table 3. Test Condition Tolerance for Charging Hierarchy	12
Table 4. Piping Requirements from Outdoor Unit to Each Indoor Unit.....	14
Table 5. Refrigerant Piping Length Correction Factors at Cooling.....	14

Table 6.	Minimum External Static Pressure (ESP) for Individual Ducted Indoor Units.....	15
Table 7.	Nominal Indoor Unit Cooling Capacity Buckets.....	17
Table 8.	Operating Conditions for Standard Rating and Performance Operating Tests for VRF Air-Source Systems	21
Table 9.	Operating Conditions for Standard Rating and Performance Operating Tests for the Determination of Cooling Capacity for VRF Water-source Heat Pumps.....	24
Table 10.	Operating Conditions for Standard Rating and Performance Operating Tests for the Determination of Heating Capacity for VRF Water-source Heat Pumps.....	24
Table 11.	Simultaneous Heating and Cooling Test Conditions	25
Table 12.	Test Operating Tolerances and Test Condition Tolerances	26
Table 13.	Values of Full System Rated Capacity	27
Table 14.	Statistics	27
Table 15.	Maximum Cooling Test Conditions for Systems that use VRF Water-source Heat Pumps	32
Table 16.	Maximum Heating Test Conditions for VRF Water-source Heat Pumps	33
Table 17.	Minimum Cooling Test Conditions for VRF Water-source Heat Pumps.....	34
Table 18.	Tolerance on Part-load Percent.....	36
Table 19.	Uncertainty Allowances.....	39

FIGURES

Figure 1.	Test Room Layout.....	15
Figure 2.	Voltage Tolerance Test Power Interrupt Procedure.....	29

APPENDICES

Appendix A.	References – Normative.....	40
Appendix B.	References – Informative.....	41
Appendix C.	Controls Verification Procedure – Normative	42
Appendix D.	Development of Supplemental Testing Instructions for Set-up and Testing – Informative	47
Appendix E.	Method of Testing Variable Refrigerant Flow Products – Normative	52
Appendix F.	Unit Configuration for Standard Efficiency Determination – Normative	70
Appendix G.	Examples of IEER Calculations – Informative.....	72
Appendix H.	Example Calculations for Critical Parameter Budget Method – Informative.....	80

TABLES FOR APPENDICES

Table C1.	Indoor Dry Bulb Temperature Tolerances – R2 Period.....	44
Table C2.	Measurement Apparatus and Data Collection Intervals for CVP Parameters	45
Table C3.	Critical Parameter Nominal Point Values.....	46
Table D1.	Example Template for Reporting Format for Critical Parameters.....	49
Table D2.	Example Piping for Heat Recovery System.....	51
Table E1.	Temperature Measurement Requirements	53
Table E2.	Criteria for Air Distribution and Control of Air Temperature	58
Table E3.	Outlet Plenum Maximum Diameter.....	61
Table G1a.	Example 1: Test Results.....	72
Table G1b.	Example 1: IEER Rating Points and Degradation Calculations	73
Table G2a.	Example 2: Test Results.....	74

Table G2b.	Example 2: IEER Rating Points and Degradation Calculations	75
Table G3a.	STI-Reported Critical Parameter Values	75
Table G3b.	Example 3: Initial Test Results	76
Table G3c.	Example 3: Test Results with Compressor Speed Adjustments	76
Table G3d.	Example 3: Power Outputs	77
Table G4a.	STI-Reported Critical Parameter Values	78
Table G4b.	Example 5: Initial Test Results	78
Table G4c.	Example 5: Adjusted Test Results	78
Table H1.	STI-Reported Critical Parameter Values	80
Table H2.	75% Instantaneous Parameter Variation Calculation	80
Table H3.	Instantaneous Parameter Point Calculation	80
Table H4.	Measurement Period Point Total Average	81

FIGURES FOR APPENDICES

Figure C1.	Controls Verification Procedure (CVP) Schematic	43
Figure D1.	Example Wiring Diagram for Heat Pump	49
Figure D2.	Example Wiring Diagram for VRF Heat Recovery System.....	50
Figure D3.	Example Piping Diagram for VRF Heat Recovery System.....	50
Figure E1.	Example Air Sampling Tree (Informative).....	54
Figure E2.	Example of an Aspirating Psychrometer (Informative).....	55
Figure E3.	Single Module Air Sampling Tree Placement Example (Informative)	59
Figure E4.	Multiple Module Air Sampling Tree Placement Example (Informative).....	59
Figure E5.	Example Configurations for Manifolding the Static Pressure Taps (Informative).....	62
Figure E6.	Example Setup for Wall Mounted Indoor Units (Informative)	65
Figure E7a.	Example Indoor Units Installation Based on Different Static Pressures (Informative).....	66
Figure E7b.	Example Indoor Units Installation for IDUs of Same Chassis Size (Informative).....	66

Figure E7c.	Example Indoor Units Installation for IDUs of Different Chassis Size (Informative).....	67
Figure E8.	Schematic of Test Setup for Ducted Indoor Units with Common Duct (Informative).....	67
Figure E9a.	Example Return Air Measurement Setup for Non-Ducted Units, Sampling Tree at Unit (Informative).....	68
Figure E9b.	Example Return Air Measurement Setup for Non-Ducted Units, Sampling Tree Common (Informative).....	68
Figure E10.	Example Return Air Measurement Setup for Ceiling Cassette (Informative).....	69
Figure E11.	Example VRF System Setup in Laboratory (Informative).....	69

PERFORMANCE RATING OF VARIABLE REFRIGERANT FLOW (VRF) MULTI-SPLIT AIR-CONDITIONING AND HEAT PUMP EQUIPMENT

Section 1. Purpose

1.1 Purpose. This standard establishes definitions, classifications, test requirements, rating requirements, determination of Published Ratings, operating requirements, marking and nameplate data, conformance conditions, and minimum data requirements for Published Ratings and calculations for Variable Refrigerant Flow (VRF) Multi-split Air Conditioners and Heat Pumps.

1.1.1 Intent. This standard is intended for the guidance of the industry, including manufacturers, engineers, installers, contractors, and users.

Specific interests include, but are not limited to, federal/state/provincial regulations and efficiency standards developed by ASHRAE, the International Energy Conservation Code (IECC), the Canadian Standards Association (CSA), and the United States Department of Energy (DOE).

1.1.2 Review and Amendment. This standard is subject to review and amendment as technology advances.

Section 2. Scope

2.1 This standard applies to VRF Multi-split Air Conditioners and Multi-split Heat Pumps using distributed refrigerant technology, including VRF Water-source Heat Pump systems of any Cooling Capacity and VRF Air-source systems with Cooling Capacity $\geq 65,000$ Btu/h, as defined in Section 3 and referenced as the Basic Model.

If this standard is used to demonstrate regulatory compliance, stakeholders shall abide by all published requirements applicable to the regulated product. For example, for products that contain one or more design characteristics that either prevent testing according to this standard or cause this standard to evaluate the equipment in a manner unrepresentative of the equipment's true energy consumption characteristics, DOE requires the manufacturer submit a petition for waiver that includes an alternative method of test.

2.2 This standard applies to VRF Systems defined in Section 3.2.47.

2.3 Exclusions. This standard does not apply to the rating and testing of:

- Individual assemblies, such as separate condensing units or indoor units;
- Air-conditioners and Heat Pumps, with capacities less than 65,000 Btu/h as defined in AHRI 210/240;
- Water-source Heat Pumps (other than Multi-split Systems) as defined in AHRI/ASHRAE/ISO 13256-1 (RA 2012);
- Unitary Air-conditioners and Unitary Heat Pumps as defined in AHRI 340/360, with capacities $\geq 65,000$ Btu/h;
- Units equipped with desuperheater/water heating devices as defined in AHRI 470; and
- Commercial and Industrial Condensing units with a capacity greater than 135,000 Btu/h as defined in AHRI 365 (I-P).

2.4 Energy Source. This standard applies only to electrically operated, vapor compression refrigeration systems.

Section 3. Definitions

All terms in this document shall follow the standard industry definitions in the ASHRAE Terminology website unless otherwise defined in this section.

For this standard, the terms “equipment” and “systems” are used throughout to refer to Multi-split Air-conditioners or Multi-split Heat Pumps, or both unless otherwise specified.

3.1 Expression of Provisions

Terms that provide clear distinctions between requirements, recommendations, permissions, options, and capabilities.

3.1.1 “Can” or “Cannot”. Express an option or capability.

3.1.2 “May”. Signifies a permission expressed by the document.

3.1.3 “Must”. Indication of unavoidable situations and does not mean that an external constraint referred to is a requirement of the document.

3.1.4 “Shall” or “Shall not”. Indication of mandatory requirements to strictly conform to the standard and where deviation is not permitted.

3.1.5 “Should” or “Should not”. Indication of recommendations rather than requirements. In the negative form, a recommendation is the expression of potential choices or courses of action that are not preferred but not prohibited.

3.2 Standard Specific Definitions

3.2.1 *Air Sampling Device(s)*. A combination of Air Sampling Tree(s), conduit, fan and Aspirating Psychrometer or Dew point Hygrometer used to determine dry-bulb temperature and moisture content of an air sample from critical locations.

3.2.1.1 *Air Sampling Tree*. An assembly consisting of a manifold with two or more branch tubes with multiple sampling holes that draws an air sample from the unit under test from a critical location such as an indoor air inlet, indoor air outlet, or outdoor air inlet.

3.2.1.2 *Aspirating Psychrometer*. An instrument used to determine the humidity of air by simultaneously measuring both the wet-bulb and dry-bulb temperatures. The difference between these temperatures is referred to as the wet-bulb depression.

3.2.1.3 *Dew Point Hygrometer*. An instrument used to determine the humidity of air by detecting visible condensation of moisture on a cooled surface.

3.2.2 *Airflow-control Setting(s)*. Programmed or wired control system configurations that control a fan to achieve discrete, differing ranges of airflow—often designated for performing a specific function such as cooling, heating, or constant circulation—without manual adjustment other than interaction with a user-operable control such as a thermostat as specified in the Manufacturer’s Installation Instructions.

3.2.3 *Approach Temperature*. The refrigerant temperature at the outdoor liquid service port minus the outdoor ambient temperature.

3.2.4 *Basic Model*. All units manufactured by one manufacturer within a single equipment class, that have the same or comparably performing compressor(s), a common Nominal Cooling Capacity, and the same heat rejection medium such as air or water.

3.2.5 *Bubble Point*. Refrigerant liquid saturation temperature at a specified pressure.

3.2.6 *Capacity*

3.2.6.1 *Cooling Capacity*. The capacity associated with the change in air enthalpy that includes both the Latent Capacity and Sensible Capacity expressed in Btu/h.

3.2.6.2 *Heating Capacity*. The capacity associated with the change in dry-bulb temperatures expressed in Btu/h.

3.2.6.3 *Latent Cooling Capacity*. The rate that the equipment removes latent heat to reduce the moisture content of the air passing through the equipment under specified conditions of operation, Btu/h.

3.2.6.4 *Nominal Cooling Capacity* (for Indoor Unit and Outdoor Unit). The approximated cooling capacity, when referenced, at Standard Rating Conditions, as published in product literature, Btu/h.

3.2.6.5 *Percent Load*. The ratio of the part-load Cooling Capacity over the measured full load Cooling Capacity at Standard Rating Conditions, expressed in units of percent, %.

3.2.6.6 *Rated Capacity*. The capacity achieved at the Standard Rating Conditions, Btu/h.

3.2.5.6.1 *Standard Rating Cooling Capacity*. The capacity of the system when all Indoor Units and Outdoor Units are all operated in cooling mode, in the Standard Rating Conditions Cooling, Btu/h.

3.2.5.6.2 *Standard Rating Heating Capacity*. The capacity of the system when all Indoor Units and Outdoor Units are operated in heating mode, in the Standard Rating Conditions (High Temperature Heating Steady-state Test and Low Temperature Heating Steady-state Test), Btu/h.

3.2.5.7 *Sensible Cooling Capacity*. The rate that the equipment lowers the dry-bulb temperature (removes sensible heat) of the air passing through the equipment under specified conditions of operation, Btu/h.

3.2.5.8 *Total Cooling Capacity*. The capacity associated with the change in air enthalpy that includes both the latent and sensible capacities expressed in Btu/h.

3.2.7 *Coefficient of Performance (COP)*. A ratio of the Heating Capacity in Btu/h to the power input values in Btu/h at any given set of Rating Conditions expressed in Btu/h/Btu/h.

3.2.7.1 *Coefficient of Performance at High Temperature (COP_H)*. The Coefficient of Performance, not including supplementary resistance heat, obtained at the 47°F temperature Rating Condition.

3.2.7.2 *Coefficient of Performance at Low Temperature (COP_L)*. The Coefficient of Performance obtained at the 17°F temperature Rating Condition.

3.2.9 *Control Setting(s)*. System configurations specified in the Manufacturer’s Installation Instructions (MII) and Supplemental Testing Instructions (STI).

3.2.10 *Controls Verification Procedure (CVP)*. The procedure to verify the Control Settings for the Critical Parameters used during the Steady-state Test. (See Appendix C.)

3.2.11 *Critical Parameter(s)*. Key variables affecting the measured result. Any operating state or position for a component, either set manually or automatically by System Controls that can impact system performance. The settings of modulating components of a VRF System are: compressor speed(s), outdoor fan speed(s), and outdoor variable valve position(s).

3.2.12 *Degradation Coefficient (C_D)*. A parameter used in calculating the part-load factor, a measure of the efficiency loss due to the cycling of the units.

3.2.13 *Desiccant Dehumidification Components*. An assembly that reduces the moisture content of the supply air through moisture transfer with solid or liquid desiccants.

3.2.14 *Dew Point*. Refrigerant vapor saturation temperature at a specified pressure.

3.2.15 *Economizers*.

3.2.15.1 *Air Economizer*. An optional feature that brings in additional outside cool air to cool the building when ambient temperature and or humidity levels are lower than the return air conditions.

3.2.15.2 *Integrating Economizing*. A control mode where both the economizer and mechanical cooling are operated to satisfy the building load. The economizer is operated at maximum capacity and the mechanical cooling is used to supplement the economizer cooling.

3.2.16 *Energy Efficiency Ratio (EER)*. A ratio of the Cooling Capacity in Btu/h to the power input value in watts at any given set of Rating Conditions expressed in Btu/(W·h).

3.2.16.1 *Integrated Energy Efficiency Ratio (IEER)*. A weighted calculation of mechanical cooling efficiencies at full load and part load Standard Rating Conditions, as outlined in Section 11 expressed in Btu/h)/(W·h).

3.2.17 *Fresh Air Dampers*. An assembly with dampers and means to set the damper position in a closed and one open position so that the air is drawn into the equipment when the indoor fan is operating.

3.2.18 *Hail Guards*. A grille or similar structure mounted to the outside of the unit covering the outdoor coil to protect the coil from hail, flying debris and damage from large objects.

3.2.19 *Heat Pump(s)*. A kind of central air conditioner(s) that utilizes an indoor conditioning coil, compressor, and refrigerant-to-outdoor air heat exchanger to provide air heating, and can provide air cooling, air dehumidifying, air humidifying, air circulating, and air cleaning.

3.2.20 *Heat Recovery Control Unit*. A device that controls refrigerant flow between Indoor Units, so that there is simultaneous cooling and heating operation.

3.2.21 *Indoor Unit*. A separate assembly of a Split System, excluding a service coil, that includes all of the following features:

- An arrangement of refrigerant-to-air heat transfer coil(s) for transfer of heat between the refrigerant and the indoor air
- A condensate drain pan
- An air temperature sensing device
- An integrated indoor blower such as a device to move air including the device's associated motor

Units can include any or all of the following features:

- Sheet metal or plastic components not part of external cabinetry to direct/route airflow over the coil(s)
- Cooling mode expansion device
- External case

3.2.21.1 *Ducted Indoor Unit*. An Indoor Unit designed to be permanently installed and deliver all conditioned air through ductwork.

3.2.21.2 *Non-ducted Indoor Unit*. An Indoor Unit designed to be permanently installed, mounted on room walls, floors, or ceilings, or any combination thereof, that directly heats or cools air within the conditioned space and consists of the following types:

- Wall-mounted
- Floor-mounted
- Ceiling-suspended
- Standard Four-way Ceiling Cassette
- Compact Four-way Ceiling Cassette

3.2.22 *Individual Model*. An Individual Model means a model distributed in commerce with a unique model number.

3.2.23 *Indoor Unit Model Family*. A group of indoor unit models consisting exclusively of the same kind of indoor units, as specified in Section 3.2.23.1, Section 3.2.23.2 and Section 3.2.23.3.

3.2.23.1 *Non-ducted Indoor Unit Model Families*

3.2.23.1.1 *Ceiling-suspended*. A non-ducted Indoor Unit that is totally encased and is suspended below the ceiling.

3.2.19.1.2 *Floor-mounted.* A non-ducted Indoor Unit intended for being installed at floor level either enclosed in the wall space in an uncased configuration or extended out from the wall in a cased configuration.

3.2.23.1.3 *Ceiling Cassette.* Non-ducted Indoor Units intended to be installed flush mounted with the ceiling. These Indoor Units can have configurations of indoor airflow coming from one, two, four, or circular direction(s). Each of the following represents a separate Indoor Unit Model Family:

3.2.23.1.3.1 *Compact. Four-way Ceiling Cassette.* A Ceiling Cassette with air discharge louvers on four or more sides (or circular), a central air return grill and main casing dimensions less than 32 in x 32 in (not including flanges).

3.2.23.1.3.2 *One-way Cassette.* A Ceiling Cassette with air discharge louvers on a single side.

3.2.23.1.3.3 *Standard Four-way Ceiling Cassette.* A Ceiling Cassette with air discharge louvers on four or more sides (or circular), a central air return grill and main casing dimensions greater than, or equal to, 32 in x 32 in (not including flanges).

3.2.23.1.3.4 *Three-way Cassette.* A Ceiling Cassette with air discharge louvers on three sides.

3.2.23.1.3.5 *Two-way Cassette.* A Ceiling Cassette with air discharge louvers on two sides.

3.2.23.1.4 *Wall-mounted.* A non-ducted Indoor Unit that is attached to the wall with a cased configuration.

Note: These units can be referred to as high-wall units.

3.2.23.2 *Ducted Indoor Unit Model Families.* Model families when operated at the full-load cooling airflow that produces the following ESP range:

3.2.23.2.1 *Low-static.* A ducted Indoor Unit that produces an external static pressure (ESP) between 0.01 in H₂O and 0.35 in H₂O.

3.2.23.2.2 *Mid-static.* A ducted Indoor Unit that produces an ESP between 0.20 in H₂O and 0.65 in H₂O.

If the Indoor Unit model grouping in a manufacturer's publicly accessible literature is not in accordance with Section 3.2.23.2, Section 3.2.23.2 takes precedence for the determination of Tested Combinations.

If the range of ESP as published in manufacturer's publicly accessible literature for an Indoor Unit falls within the ESP range for more than one type of Ducted System, then the Indoor Unit is classified based on where much of the ESP capability lies.

If an Indoor Unit can operate between 0.15 in H₂O and 0.65 in H₂O, then this Indoor Unit is designated as a Mid-static Indoor Unit. If an Indoor Unit can operate between 0.35 in H₂O and 0.75 in H₂O, then this Indoor Unit is designated as a Mid-static Indoor Unit.

3.2.23.3 *Small-duct, High-velocity (SDHV) Indoor Unit Model Family.* An Indoor Unit designed to be permanently installed and deliver all conditioned air through ductwork and that produces at least 1.2 in H₂O of ESP when operated at the full-load cooling airflow of at least 220 scfm per ton of Nominal Cooling Capacity. This Indoor Unit Model Family is a unique type that is not one of the Ducted Indoor Unit Model Families.

3.2.24 *Low Ambient Cooling Dampers.* An assembly with dampers and means to set the dampers in a position to recirculate the warmer condenser discharge air so that there is reliable operation at low outdoor ambient conditions.

3.2.25 *Manufacturer's Installation Instructions (MII)*. Manufacturer documents that come packaged with or appear in the labels applied to the unit(s). Online manuals can be used if referenced on the unit label or in the documents that come packaged with the unit.

3.2.25.1 *Manufacturer-Specified*. Required information provided by the manufacturer through either the STI or MII.

3.2.25.2 *Supplemental Testing Instructions (STI)*. Additional instructions developed by the manufacturer for the purpose of being able to test a VRF System to this test standard. Refer to Section 5.4 for STI requirements.

3.2.26 *Nominal Point Value*. The value that corresponds to a 1% variation in the given critical parameter. Refer to Table C3 for individual parameter values.

3.2.27 *Oil Recovery Mode*. An automatic system operation that returns oil to the compressor crankcase when the control system determines that the oil level in the Outdoor Unit is low.

3.2.28 *Outdoor Two-position Valves*. Two-position refrigerant valves in the Outdoor Unit.

3.2.29 *Outdoor Unit*. A separate assembly of a Split System that transfers heat between the refrigerant and the outdoor air or refrigerant and water, and consists of an outdoor heat exchanger, compressor(s), an air moving device, and in addition for Heat Pumps, can include a heating mode expansion device, reversing valve, or defrost controls, or any combination thereof. VRF Water-source Heat Pumps do not have an air movement device.

3.2.29.1 *Combined Module*. Two or more Single Modules that are mechanically and electronically joined together to operate as a single Outdoor Unit, and that is assembled with multiple Indoor Units to form a system. When such equipment is provided in more than one assembly, the separated assemblies are designed to be used together, and the requirements of rating outlined in the standard are based upon the use of matched assemblies.

3.2.29.2 *Single Module*. A single Outdoor Unit that is assembled with multiple Indoor Units and controls to form a system.

3.2.30 *Outdoor Variable Valves*. Variable position refrigerant valves in the Outdoor Unit.

3.2.31 *Power Correction Capacitors*. A capacitor that increases the power factor measured at the line connection to the equipment.

3.2.32 *Published Rating*. A statement of the assigned values of those performance characteristics, under stated Rating Conditions, where a unit can be chosen to fit the application. These values apply to all units of the same nominal size and type (identification) produced by the same manufacturer. This includes the rating of all performance characteristics shown on the unit or published in specifications, advertising or other literature controlled by the manufacturer, at stated Rating Conditions.

3.2.32.1 *Application Rating*. A rating based on tests performed at Rating Conditions other than Standard Rating Conditions.

3.2.32.2 *Standard Rating*. A rating based on tests performed at Standard Rating Conditions.

3.2.33 *Rating Conditions*. Any set of operating conditions where a single level of performance results and causes only that level of performance to occur.

3.2.33.1 *Standard Rating Condition*. Rating Conditions used as the basis of comparison for performance characteristics.

3.2.34 *Return Air Temperature Unit Sensor(s)*. A factory installed component that measures the temperature of the return air or indoor room air entering the unit under test.

3.2.35 *Root Sum of Square Point Total (RSS Point Total)*. An instantaneous measure of Critical Parameter variation, the root-sum-square of the points accrued by all overridden critical parameters, as defined by Equation C5.

- 3.2.36** *Sensible Heat Ratio (SHR)*. A ratio of the Sensible Cooling Capacity to the Total Cooling Capacity at a given condition.
- 3.2.37** *Set Point Bias*. The difference between 80°F and the nominal thermostat set point required for the thermostat to control for 80°F-sensed temperature at the sensed location.
- 3.2.38** *Set Point Offset*. The difference between the temperature indicated by a thermostat's temperature sensor and the actual temperature at the sensor's location.
- 3.2.39** *Service Tool*. A manufacturer's tool for checking system hardware/software, often provided as a download from either the manufacturer's certified installer website or from an authorized representative.
- 3.2.40** *Simultaneous Cooling and Heating Efficiency (SCHE)*. The ratio of the total capacity of the system (heating and cooling capacity) to the Total Power when operating in the heat recovery mode, (Btu/h)/W.
- 3.2.41** *Small-duct, High-velocity System (SDHV)*. Split System where all Indoor Units are SDHV Indoor Units.
- 3.2.42** *Stable Conditions*. Balanced operating conditions in the indoor and outdoor section of the test chamber where the test unit is maintaining Steady-state Test conditions and the test chamber is maintaining test room conditions within prescribed tolerances.
- 3.2.43** *Standard Air*. Air weighing 0.075 lb/ft³ that approximates dry air at 70°F and 29.92 in Hg.
- 3.2.44** *Standard Airflow*. The volumetric flowrate of air corrected to standard air conditions, in scfm.
- 3.2.45** *Standard Rating Test*. Tests performed at Standard Rating Conditions.
- 3.2.46** *Steady-state Test*. A test where the controlled test parameters are regulated to remain within the specified tolerances while the unit operates continuously in the same mode.
- 3.2.47** *Steam or Hydronic Coils*. An assembly that conditions air through coils containing steam or water.
- 3.2.48** *System Controls*. A set of mechanical and electrical devices that manages, commands, directs or regulates the behavior of the unit(s) under test. The system can include:
- An integral network operations and communications system with sensors to monitor the status of items such as temperature, pressure, oil, refrigerant levels, and fan speed.
 - A microprocessor, algorithm-based control scheme to:
 - communicate with a managed compressor(s), fan speed of Indoor Units, fan speed of the Outdoor Unit(s), solenoids, other accessories
 - manage metering devices
 - concurrently operate multiple parts of the system.
 - Regulate system efficiency and refrigerant flow through an engineered distributed refrigerant system to conduct zoning operations, matching capacity to the load in each of the zones.
- 3.2.49** *Test Condition Tolerance*. The maximum permissible difference between the average value of the measured test parameter and the specified test condition.
- 3.2.50** *Test Operating Tolerance*. The maximum permissible range a measurement can vary over the specified test interval. When expressed as a percentage, the maximum allowable variation that can be used is the specified percentage of the average value.
- 3.2.51** *Tested Combination*. An arrangement of Indoor Units and Outdoor Units that are production units (or for product development purposes are representative of production units) and provides representative performance values. Refer to Section 6.2 for the requirements for these arrangements.

3.2.52 *Thermally Active.* The state of an Indoor Unit when the unit is cooling, as indicated by the digital on/off signal from the Service Tool or by a liquid expansion valve (LEV) position indicated by the Service Tool greater than the minimum LEV position for that valve.

3.2.53 *Thermally Inactive.* The state of an Indoor Unit when the unit is not Thermally Active.

3.2.54 *Total Power.* The sum of the average electrical power input consumed by all components of a system, expressed as W, including all of the following:

- Power input for operation of the compressor(s)
- Power input to electric heating devices used only for defrosting
- Power input to all control and safety devices of the equipment
- Power input to factory installed condensate pumps
- Power input for operation of all fans and, if applicable, any Water-source condenser pump(s) (including pump power adjustments)

3.2.55 *Variable Refrigerant Flow (VRF) System.* An engineered direct expansion (DX) air-conditioning or Heat Pump multi-split system that incorporates the characteristics and components:

- A single refrigerant circuit that has a common piping network to multiple Indoor Units;
- Single Module or Combined Module Outdoor Units;
- Two or more Indoor Units;
- Three or more steps of capacity; and
- A zone temperature control device such as a thermostat.

Note: VRF Systems less than 65,000 Btu/h Cooling Capacity are designated as central air conditioners and central air conditioning Heat Pumps in 10 CFR §429, 10 CFR §430, and 10 CFR §431.

3.2.55.1 *VRF Air-source System.* A VRF Heat Pump with Single Module or Combined Module Outdoor Units that have air-to-refrigerant heat exchangers.

3.2.55.2 *VRF Heat Recovery System.* A VRF Air-source System or VRF Water-source Heat Pump capable of providing simultaneous heating and cooling operation through a Heat Recovery Control Unit, where recovered energy from the Indoor Units operating in one mode can be transferred to one or more other Indoor Units operating in the other mode.

Note: This can be achieved by a gas/liquid separator or a third line in the refrigeration circuit.

3.2.55.3 *VRF Water-source Heat Pump.* The Heat Pump consists of one or more factory-made assemblies that can include an indoor conditioning coil with air moving means, compressor(s), and refrigerant-to-fluid heat exchanger(s), including a means to provide both cooling and heating functions. The three main types of VRF Water-source Heat Pumps are;

3.2.55.3.1 *Ground-loop Heat Pump.* A Brine-to-air Heat Pump that uses a brine solution circulating through a subsurface piping loop as a heat source/heat sink.

Note: The heat exchange loop can be placed in horizontal trenches, vertical bores, or be submerged in a body of surface water. The temperature of the brine is related to the climatic conditions and can vary from 23°F to 104°F.

3.2.55.3.2 *Ground-water Heat Pump.* A Water-source Heat Pump that uses water pumped from a well, lake, or stream as a heat source/heat sink.

Note: The temperature of the water is related to the climatic conditions and can vary from 41°F to 77°F for deep wells.

3.2.55.3.3 *Water Loop Heat Pump.* A Water-source Heat Pump using liquid circulating in a common piping loop as a heat source/heat sink.

Note: The temperature of the liquid loop can be controlled to be within a temperature range of 59°F to 104°F.

3.2.56 Variable Speed Compressor. A compressor that has capability of varying the rotational speed in non-discrete stages or steps from low to intermediate to full using an inverter or variable frequency drive.

3.2.57 Ventilation Energy Recovery System (VERS). An assembly that preconditions outdoor air entering the equipment through direct or indirect thermal or moisture exchange with the exhaust air, or both, defined as the building air being exhausted to the outside from the equipment. Also known as exhaust air energy recovery.

Section 4. Classifications

4.1 Equipment covered within the scope of this standard shall be classified as shown in Table 1.

Table 1. Classification of VRF Systems		
System Identification	VRF Air-conditioner or Heat Pump System	VRF Heat Recovery System
Air-conditioner (Air-source)	MSV-A-CB ¹	Not Applicable
Air-conditioner (Water-source)	Not Applicable	Not Applicable
Heat Pump (Air-source)	HMSV-A-CB ¹	HMSR-A-CB ¹
Heat Pump (Water-source)	HMSV-W-CB ¹	HMSR-W-CB ¹
Note: <ul style="list-style-type: none"> • “-A” indicates Air-source condenser and “-W” indicates Water-source condenser. 		

Section 5. Test Requirements

5.1 Test Requirements. All testing for Standard Ratings shall be conducted in accordance with the test methods and procedures described in this standard.

5.1.1 Standards. VRF Systems shall be tested in accordance with Section 6, Appendix C, and Appendix E. Additionally, VRF Water-source Heat Pump systems shall be tested in accordance with Section 6.3.1.6 of ASHRAE 30.

5.1.2 Equipment setup. To set up equipment for test, manufacturer authorized personnel with knowledge of the control software can support commissioning of the system being tested.

5.1.2.1 Critical Parameters. At each load point, Critical Parameters shall be set to the values in the STI. In cases where a Critical Parameter value is not in the STI, the system shall operate by commands from the System Controls for that parameter. Once set, Control Settings shall remain unchanged for the remainder of the test (except for allowable adjustment of Critical Parameters as described in Section 6.3.3 for IEER tests). The initial setting and any allowable adjustment of Critical Parameters shall be performed by manufacturer authorized personnel and monitored by a member of the laboratory.

5.1.2.2 Control Settings. Control Settings other than Critical Parameters shall be set by a member of the laboratory. All Control Settings are to remain unchanged for all load points once system setup has been completed.

Airflow-control Settings shall be in accordance with Section 6.3.1.

5.1.2.3 Thermally Active State. If the Thermally Active state of an indoor unit cannot be determined from the digital on/off signal from the Service Tool, active status is indicated by an LEV position indicated by the Service Tool greater than the minimum LEV position for that valve. The time history of the temperature difference between the inlet and outlet thermocouple grids of an indoor unit can be examined to verify either of these indication methods.

5.1.3 *Oil Recovery Mode.* The Oil Recovery Mode shall be enabled during testing. If the Oil Recovery Mode prevents a Steady-state Test, use the transient test procedure as described in Section 8.8.3, except Section 8.8.3.3, of ASHRAE 37, with the following modifications:

For tests of VRF Systems that cannot reach steady state because of Oil Recovery Mode, Section 8.8.3 (except Section 8.8.3.3) of ASHRAE 37 shall be modified by replacing all mentions of “defrost” with “Oil Recovery Mode”, replacing all mentions of “Heat Pump” with “system” and replacing all mentions of “heating” with “conditioning”. The test tolerances specified in Table 2 of ASHRAE 37 for “heat portion” under “heat with frost” shall be satisfied when conducting the tests. The test tolerance parameters included in Table 2 of ASHRAE 37 shall be sampled throughout the preconditioning and data collection period. To evaluate compliance with the specified test tolerances, the dry-bulb temperature of the air entering the indoor-side and the outdoor-side and the water vapor content of the air entering the indoor or outdoor-side shall be sampled at least every minute. All other parameters shall be sampled at equal intervals that span five minutes or less.

5.1.4 *Defrost Controls.* Defrost controls shall be left at manufacturer’s factory settings if the MII provided with the equipment do not specify otherwise. Any Control Settings for defrost specified by the MII that can be achieved through methods outlined in the MII can be used to achieve Steady-state Test operation. If unable to run a Steady-state Test procedure due to Control Settings for defrost, the transient test procedure as defined in ASHRAE 37 shall be used with the following exclusions:

- The Test Operating Tolerance for the outdoor entering conditions is omitted during the defrost portion.
- The Test Operating Tolerances and Test Condition Tolerances for the heat portion shall apply when the unit is in heating mode except for the first thirty minutes after terminating a defrost cycle.

To facilitate testing of any unit, the manufacturer shall provide information and any necessary hardware to manually initiate a defrost cycle.

5.1.5 *Indoor Unit Temperature Control Set Point.* The temperature set point for each Indoor Unit that is Thermally Active shall be set to 80°F.

5.1.5.1 *Set Point Offsets.* Identify and correct for Set Point Offset(s) that can be present in indoor unit thermostats by using the following procedures. Round set point adjustments to the nearest set point increment.

5.1.5.1.1 *Independent Return/Indoor Ambient Air Temperature Unit Sensor.* If the control for the Indoor Unit utilizes an independent return/indoor ambient air temperature unit sensor for each Indoor Unit, adjust the set point for each Indoor Unit by the difference between the measurements of the return air thermocouple grid and the Return Air Temperature Unit Sensor. The latter can be determined using either the on-board thermostat reading or the Service Tool.

5.1.5.1.2 *Common Return Air Temperature Unit Sensor.* If the control for the Indoor Unit utilizes a common Return Air Temperature Unit Sensor for multiple Indoor Units in operation, make a single adjustment by the difference between the average of the thermocouple grid measurements and the Indoor Units group’s return/ambient air temperature sensor that is determined using either the on-board thermostat reading or from the Service Tool.

5.1.5.2 *Set Point Bias.* If the controls of the unit under test include a Set Point Bias, the manufacturer can include the Set Point Bias in the STI. If a Set Point Bias is included in the STI, the temperature set point for each Indoor Unit that is Thermally Active shall be set to 80°F, less the STI-reported Set Point Bias up to 2°F. If the controls have a Set Point Bias and there is also Set Point Offset, the temperature set point for each Indoor Unit that is Thermally Active shall be set to 80°F, less the STI-reported Set Point Bias up to 2°F, plus the difference between the thermocouple grid measurement or average and the Return Air Temperature Unit Sensor.

5.2 *Head Pressure Control for VRF Air-source Systems and VRF Water-source Heat Pump Systems.* For units that have condenser head pressure control to verify proper flow of refrigerant through the expansion valve during low condenser air or water inlet temperature conditions, the head pressure controls shall be enabled and operate in automatic control mode. The setting shall be set at the factory settings or as defined in the MII.

If the head pressure control is engaged by the control logic during part-load cooling tests, then use the following steps. For all part-load cooling tests for VRF Water-source Heat Pump systems, the water flow rate shall not exceed the value for the full-load cooling test.

5.2.1 *Control Logic.* The System Controls shall control the operation of the unit. If the unit can be run and Stable Conditions are obtained and the test tolerances in Table 15 are met, then a standard part-load cooling test shall be run.

5.2.2 *Head Pressure Control Time Average Test.* If the head pressure control results in unstable conditions and the test tolerances in Table 15 cannot be met, then a series of two one-hour Steady-state Tests shall be run. Prior to the first one-hour test the condenser entering temperature, meaning the outdoor air dry-bulb temperature or condenser water temperature, defined by Table 8 or Table 9 as applicable shall be approached from at least a 10°F greater than temperature until the tolerances specified in Table 2 are met. Prior to the second one-hour test, the condenser entering temperature defined by Table 8 or Table 9 as applicable shall be approached from at least a 5°F less than temperature until the tolerances specified in Table 2 are met. For each test, once all tolerances in Table 2 are met, the one-hour test shall be started and test data shall be recorded every five minutes for one hour, resulting in twelve test measurements for each test parameter. During each one-hour test, the tolerances specified in Table 2 shall be met.

If the tolerances in Table 2 are met, the test results for both one-hour Steady-state Tests shall then be averaged to determine the capacity and efficiency that is to be used for the IEER calculation.

5.2.3 *Tolerances Not Met.* If the tolerances in Table 2 cannot be met for the head pressure control time average test, MII shall be used to determine the settings required to stabilize operation. However, if the MII does not provide guidance for stable operation or results in a condensing (liquid outlet) pressure corresponding to a Bubble Point temperature less than 75°F, proceed to Section 5.2.4.

5.2.4 *Manufacturer's Installation Instructions Cannot be Used.* If the MII cannot be used to achieve stable operation, the fan(s) for Air-Source units or valve(s) for VRF Water-source Heat Pump systems causing the instability shall be set manually at a speed, operating state (on/off), or positioned to achieve a condensing liquid outlet pressure corresponding to a Bubble Point temperature as close to 85°F as can be achieved while not dropping less than 85°F.

5.3 *Instruments.* Use instruments that meet the applicable requirements specifications in Section 5 of ASHRAE 37 with the amendments in Section 5.3.1 and Section 5.3.2.

5.3.1 For measurement of indoor and outdoor air temperatures, the provisions of Appendix E4 of this standard applicable to instruments take precedence over Section 5 of ASHRAE 37.

5.3.2 The atmospheric pressure measuring instruments shall be accurate to within $\pm 0.5\%$ of the reading.

5.4 *Literature Hierarchy.* For system set-up and Control Settings, use specifications from the STI. For instructions not specified in the STI, the hierarchy shall be Outdoor Unit MII, followed by the Outdoor Unit labels, followed by the Indoor Unit MII. For settings not specified in any of the preceding sources, the as-shipped setting shall be used.

STI shall include all instructions that do not deviate from the MII but provide additional specifications for test standard requirements where there is more than one option in the MII. In addition, documentation of settings and software required to obtain all deviations from the MII necessary to comply with Steady-state Test requirements shall be included.

STI shall provide steady operation that matches to the extent possible the average performance that can be obtained without deviating from the MII. STI shall not include instructions that deviate from the MII other than those described in this section.

		Operating Tolerance	Condition Tolerance
Indoor air dry-bulb temperature (°F)	Entering	3.0	1.0
	Leaving	3.0	-
Indoor air wet-bulb temperature (°F)	Entering	1.5	0.5
	Leaving	1.5	—
Outdoor air dry-bulb temperature (°F)	Entering	3.0	1.0
	Leaving	—	—
Outdoor air wet-bulb temperature (°F)	Entering	1.5	—
	Leaving	—	—
Water serving outdoor coil temperature (°F)	Entering	0.75	0.3
	Leaving	0.75	—
Voltage		2%	1%

5.5 Test Unit Location. All Indoor Unit(s) and VRF Water-source Heat Pump Outdoor Unit(s) shall be in an indoor test room(s) such as a test chamber(s) maintained at the air conditions specified for return indoor air during all tests. VRF Air-source System Outdoor Unit(s) shall be in an outdoor test room(s) such as a test chamber(s) maintained at the air conditions specified for outdoor ambient air during all tests.

5.6 Heat Recovery Control Units. For VRF Heat Recovery Systems, the Heat Recovery Control Unit shall be attached during all tests.

5.7 Atmospheric Pressure. Tests shall be conducted at an atmospheric pressure of at least 13.7 psia.

5.8 Refrigerant Charging. All test samples shall be charged at Standard Rating Conditions in accordance with the MII or labels applied to the unit. If the MII gives a specified range for superheat, sub-cooling, or refrigerant pressure, the average of the range shall be used to determine the refrigerant charge.

In the event of conflicting information between charging instructions, use the hierarchy of Section 5.4. Conflicting information is defined as multiple conditions given for charge adjustment where all conditions specified cannot be met.

In such instances, follow the hierarchy in Table 3 for priority unless the manufacturer specifies a different priority. Unless the manufacturer specifies a tighter charging tolerance, the tolerances specified in Table 3 shall be used.

Charging Method		Test Condition Tolerance of the Target Value in the MII, ±
1	Charge Weight	1.0 oz
2	Sub-cooling	10%; Not less than 0.5°F, not more than 2.0°F
3	High Side Pressure or Saturation Temperature	4.0 psi or 1.0°F
4	Low Side Pressure or Saturation Temperature	2.0 psi or 0.8°F
5	Approach Temperature	1.0°F

The resulting refrigerant charge obtained shall then be used to conduct all cooling cycle and heating cycle tests unless an adjustment is required based on the sections below. Once the correct refrigerant charge is determined, all tests shall run until completion without further modification.

Note: After completion of all required tests, laboratories should achieve full-load cooling test conditions for thirty continuous minutes and compare the results to the previous set of full-load cooling tests. Measured charge parameters outside of those listed in Table 3 are an indication the refrigerant charge or other parameters have changed, and an analysis should be performed, and corrective actions made.

5.8.1 Heat Pumps. The refrigerant charge shall be set at the full-load cooling conditions or as specified by the manufacturer. The initial heating test shall be the high-temperature heating test. Charge parameters shall be checked in accordance with the MII (if provided). If conditions are within the range specified by MII continue with the remainder of the tests.

5.8.1.1 If heating refrigerant charge parameters are not within the range specified by the MII then the smallest adjustment to refrigerant charge to get within the heating refrigerant charge and cooling refrigerant charge parameters shall be made. If the heating and cooling refrigerant charge requirements cannot be met simultaneously, maintain the charge within the tolerance for the cooling test while keeping the charge as close as possible to the requirement for the heating test. Re-run the cooling tests after any adjustment of system charge.

5.9 *Requirements for Separated Assemblies (Applies to all Systems).* The Indoor Units and Outdoor Unit are in two separate assemblies.

5.9.1 The Indoor Units and Outdoor Unit shall be installed with a minimum of 25 ft of actual interconnecting refrigerant piping length, running from the Outdoor Unit to each of the Indoor Units. The distance is measured from the nearest Outdoor Unit to each of the Indoor Units. There is a common length of piping from the Outdoor Unit to the first branching device. Refer to Table 4 for minimum total refrigerant piping lengths for each capacity range of Outdoor Unit and configuration of either ducted or non-ducted Indoor Units. In certain testing situations, test room capacity or arrangement can cause the user to run refrigerant piping that is longer than the minimum. To validate fairness of testing, Table 5 accounts for system capacity that is lost due to the additional refrigerant piping length above the minimum. If the minimum refrigerant piping lengths provided in Table 4 need to be exceeded for at least 33%, a minimum of two lengths, of the Indoor Units, then a Cooling Capacity correction factor from Table 5 shall be applied.

5.9.2 In all cases, the absolute minimum length necessary to physically connect the system shall be used. If the minimum refrigerant piping lengths provided in Table 4 are exceeded for at least 33% (minimum of two) of the Indoor Units, then a Cooling Capacity correction factor shall be applied.

Table 4. Piping Requirements from Outdoor Unit to Each Indoor Unit

System Standard Rated Cooling Capacity, Btu/h	Systems with Non-ducted Indoor Units, ft	Systems with Ducted Indoor Units, ft
0 to <65,000 ¹	25	25
≥65,000 to <105,000	50	25
≥105,000 to <135,000	75	25
≥135,000 to <350,000	100	50
≥350,000	150	75

Note:

- For VRF Water-source Heat Pumps

Table 5. Refrigerant Piping Length Correction Factors in Cooling

Additional Piping Length, ft	Cooling Capacity Correction Factor
$3.3 < X \leq 20$	1.01
$20 < X \leq 40$	1.02
$40 < X \leq 60$	1.03
$60 < X \leq 80$	1.04
$80 < X \leq 100$	1.05
$100 < X \leq 120$	1.06

Notes:

- The Cooling Capacity correction factor is determined by the average refrigerant piping length in addition to the minimum defined in Table 4.
- This table applies to Standard Rating Cooling Capacity only.

5.9.3 For VRF Air-source Systems, at least 10 ft of the system interconnection tubing shall be exposed to the outdoor room conditions. The line diameters, insulation, installation details, evacuation and charging shall follow the MII. The manufacturer shall provide a schematic of the Tested Combination installation (see Figure 1). Refer to Appendix E for additional set-up information. For regulatory compliance, refer to Appendix D. To minimize performance degradation, surplus copper tubing shall be coiled in a space where the coils cannot be disturbed. The coils shall be horizontal with a minimum diameter of 2 ft. The coils shall be in a place where the manufacturer can check the copper tubing for any potential issues. The minimum length of the refrigerant path shall be not less than the minimum length as designated in Table 4. If the manufacturer supplies piping and does not recommend cutting to length, all the piping shall be used so long as the refrigerant path is not less than the minimum length as designated in Table 4.

5.9.4 For systems with Combined Modules, the modules shall be arranged in a straight line where able and placed with a spacing of 2 ft ± 3 in between the modules, unless the MII specifies a greater minimum spacing. If a single outdoor laboratory section cannot accommodate the straight alignment of the Combined Modules, then an L-shaped configuration shall be attempted. If an L-shaped configuration cannot be achieved, then a second outdoor laboratory section shall be used.

5.10 Indoor Unit Operation for Load Point Tests. For full-load and part-load point tests the Indoor Units that are Thermally Active shall be in accordance with the STI. For the 25% load point test, at least half of the total Indoor Units, as calculated per the total capacity of the connected Indoor Units, shall remain Thermally Inactive. Forced air circulation through any Indoor Unit that is Thermally Inactive shall be prevented. This can be achieved by blocking the inlet and outlet. For the Indoor Unit(s) that are Thermally Inactive, the indoor unit control settings shall be set to “OFF” by using the remote or wireless thermostat.

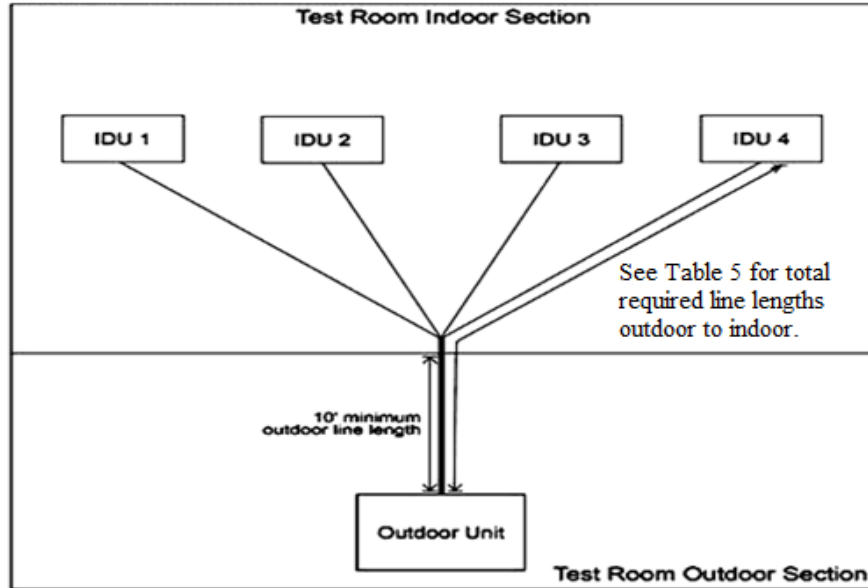

Figure 1. Test Room Layout

Section 6. Rating Requirements

6.1 Standard Ratings

6.1.1 *Nominal Cooling Capacity Requirements.* The Nominal Cooling Capacity of the Basic Model shall not be more than 105% of the Standard Rated Cooling Capacity.

6.1.2 *Minimum External Static Pressure Requirements for Ducted Indoor Units.* The minimum ESP for individual ducted Indoor Units are shown in Table 6. Small-duct, High-velocity Systems (SDHV) shall be tested at 1.15 in H₂O. If the manufacturer only has Low-static ducted models and if the manufacturer’s specified maximum external static pressure is less than 0.10 in H₂O, then the Indoor Unit shall be tested at 0.02 below the maximum external static pressure.

Capacity, Btu/h ^{1,2}	ESP ³ , in H ₂ O
Up through 28,800	0.10
29,000 to 42,500	0.15
43,000 to 70,000	0.20
71,000 to 105,000	0.25
106,000 to 134,000	0.30
135,000 to 210,000	0.35
211,000 to 280,000	0.40
281,000 to 350,000	0.45
351,000 and above	0.55

Notes:

1. The Indoor Unit capacity as specified in the MII, when operated at the Standard Rating Cooling Conditions.
2. For heating-only Heat Pumps, the value the manufacturer cites in MII for the capacity of the Indoor Unit when operated at the Standard Rating Conditions (High Temperature Steady-state Test) conditions.
3. For ducted units tested without an air filter installed, increase the applicable tabular value by 0.08 in H₂O.

6.1.3 *Electrical Conditions.* Tests shall be performed at the nameplate rated frequency. For equipment that is rated with 208/230 V dual nameplate voltages, tests conducted at Standard Rating Conditions shall be performed at 230 V. For all other dual nameplate voltage equipment covered by this standard, the tests shall be performed either at both voltages or at the lower of the two voltages if only a single Standard Rating is to be published.

6.1.4 *Integral Condensate Pump.* If a Non-ducted Indoor Unit or a Ducted Indoor Unit contains an integral condensate pump, the power to operate the pump shall be included in the system Total Power calculation.

6.2 *Tested Combinations.* A Tested Combination for all VRF Air-source Systems and VRF Water-source Heat Pump systems greater than or equal to 65,000 Btu/h consists of an Outdoor Unit and a minimum of two and a maximum of twelve Indoor Units. Only Ducted Indoor Units are used to determine the ratings for ducted VRF systems. Only Non-ducted Indoor Units are used to determine the ratings for non-ducted VRF systems.

6.2.1 The requirements for model families of Indoor Units shall be as follows:

6.2.1.1 All non-ducted Tested Combinations shall use Standard Four-way Ceiling Cassettes with the lowest normalized coil volume, as defined in Section 6.2.4. If a manufacturer does not have Four-way Ceiling Cassettes, the Tested Combination shall include Indoor Units with the lowest normalized coil volume, as defined in Section 6.2.4, only from the first Non-ducted Indoor Unit Model Family of the following when a valid Tested Combination can be assembled:

- Compact Four-way Ceiling Cassette;
- Three-way Cassette;
- Two-way Cassette;
- Wall-mounted;
- One-way Cassette; or
- Floor-mounted and Ceiling-suspended.

6.2.1.2 All ducted Tested Combinations shall use Mid-static Indoor Units with the lowest normalized coil volume, as defined in Section 6.2.4. If a manufacturer does not have Mid-static ducted units, the Tested Combination shall include indoor units with the lowest normalized coil volume, as defined in Section 6.2.4, only from the Indoor Unit Model Family with highest static capabilities. See minimum ESP requirements in Table 6.

6.2.1.3 Small-duct, High-velocity Tested Combinations shall use Small-duct High-velocity Indoor Units with the lowest normalized coil volume/motor efficiency, as defined in Section 6.2.4.

6.2.2 Indoor Units shall together have a Nominal Cooling Capacity of 100% ± 5.0% of the system Standard Rated Cooling Capacity. The Nominal Cooling Capacity of each Indoor Unit shall be the published capacity when the ratings are first established and shall not be changed upon subsequent publications.

6.2.3 Indoor Units shall not, individually, have a Nominal Cooling Capacity greater than 50% of the System Standard Rated Cooling Capacity, unless the System Standard Rated Cooling Capacity of the VRF Water-source Heat Pump is 24,000 Btu/h or less.

6.2.4 All Indoor Units shall either be production units or units representative of production units. If a manufacturer has multiple Indoor Unit models within the Capacity ranges as defined in Table 7 that meet the Tested Combination requirements, the manufacturer shall use the following criteria to select the Indoor Unit model for testing from these models. The first criterion shall be the coil size described in Section 6.2.4.1, and the second shall be the indoor fan motor efficiency described in Section 6.2.4.2.

6.2.4.1 The model with the lowest normalized coil volume, calculated using Equation 1, shall be used.

$$NCV = \frac{L_c \times W_c \times D_c}{q_{nom}} \tag{1}$$

6.2.4.2 If more than one of the models has the same lowest normalized coil volume, the one with the lowest efficiency indoor fan motor (highest fan motor input power at rated indoor airflow) shall be used for Standard Ratings.

Table 7. Nominal Indoor Unit Cooling Capacity Buckets	
Allowable Capacity Range	
Btu/h (minimum)	Btu/h (maximum)
2500	4499
4500	6499
6500	8499
8500	10,499
10,500	13,999
14,000	16,999
17,000	19,999
20,000	26,999
27,000	32,999
33,000	38,999
39,000	44,999
45,000	50,999
51,000	56,999
57,000	62,999
63,000	77,999
78,000	89,999
90,000	102,999

6.3 *Conditions for test for VRF Air-source and VRF Water-source Heat Pump Systems.* Table 8 and Table 9 indicate the test and test conditions that shall be used to measure capacity and energy efficiency. All tests listed in Table 8 and Table 9 shall be conducted at Stable Conditions. VRF Air-source Systems and VRF Water-source Heat Pump Systems with dual-rated frequencies shall be tested at each frequency.

6.3.1 *Indoor Unit Airflow and External Static Pressure.* Airflow-control Setting(s) shall be determined before testing begins. Unless otherwise identified in Section 6.3.1, changes shall not be made to the Airflow-control Setting(s) after initiation of testing. The fan operational speeds can be different for each part-load test provided that the Airflow-control setting(s) remain unchanged. The Airflow-control Setting for heating tests can be different than the Airflow-control Setting for cooling tests; however, the same Airflow-control Setting shall be used for all heating tests. For the Indoor Unit(s) that are specified Thermally Inactive, the Airflow-control Setting(s) shall be set to “OFF” in accordance with Section 5.10.

6.3.1.1 *Minimum External Static Pressure for Testing.*

6.3.1.1.1 *Non-ducted Indoor Units.* All tests shall be performed at zero ESP, with a tolerance of -0.00 to +0.02 in H₂O for all test conditions.

6.3.1.1.2 *Ducted Indoor Units.* For the full-load cooling test, test each Indoor Unit using the minimum ESP specified in Table 6. When conducting heating or part-load cooling tests when the indoor airflow rates are different than the airflow rates used for the full-load cooling test, calculate adjusted minimum ESP requirements using Equation 2. The minimum ESP requirement shall be applied to each individual Indoor Unit. For example, if half of Indoor Units are Thermally Inactive, the full-load ESP requirement is maintained for each Indoor Unit that is Thermally Active if the airflow rate through the Thermally Active Indoor Unit has not changed. If the airflow rate through a Thermally Active Indoor Unit has automatically changed through the Airflow-control Setting for a part-load test, then the ESP for that Indoor Unit shall be modified using Equation 2.

$$ESP_{adj} = ESP_{CFL} \cdot \left(\frac{Q_{dif}}{Q_{CFL}}\right)^2 \tag{2}$$

6.3.1.2 *Airflow Target Values.*

6.3.1.2.1 For the full-load cooling test, use the manufacturer-specified Airflow-control Setting for each Indoor Unit. If the cooling Airflow-control Setting is not specified by the manufacturer, use an Airflow-control Setting resulting in an airflow greater or equal to the manufacturer-specified airflow. If the cooling Airflow-control Setting or airflow are not specified by the manufacturer, use an Airflow-Control Setting that results in an airflow not greater than 400 scfm per ton, for example per 12,000 Btu/h, of Indoor Unit Nominal Cooling Capacity.

6.3.1.2.2 For the heating tests, use the manufacturer-specified Airflow-control Setting for each Indoor Unit. If the delivered airflow differs from the part-load test at the same Airflow-control setting, then adjust the minimum ESP using the value obtained in Equation 2. If the heating Airflow-control Setting is not specified by the manufacturer, use the full-load cooling Airflow-control Setting for the heating tests.

6.3.1.2.3 For the part-load cooling tests, use the full-load Airflow-control Setting as defined in Section 6.3.1.2.1. If the delivered airflow differs from the part-load test at the same Airflow-control setting, then adjust the minimum ESP in accordance with the calculation obtained in Equation 2.

6.3.1.3 *Maximum Airflow for Non-ducted Indoor Units.* For cooling tests, maximum airflow for any indoor unit shall not exceed the lower of the following limits:

- 105% of the nominal airflow as published in product literature for that unit; or
- 55 scfm per 1000 Btu/h of nominal Indoor Unit cooling capacity.

If the airflow rate exceeds either or both limits, then use an Airflow-control Setting that results in an airflow not greater than the lower of the two limits mentioned in this section.

For heating tests, there is not a maximum airflow if the Airflow-control Setting used in the heating test is the same as the Airflow-control Setting used in the full-load cooling test. If the Airflow-control Setting used is different, the heating airflow shall not exceed 55 scfm per 1000 Btu/h of nominal Indoor Unit cooling capacity. If 55 scfm per 1000 Btu/h is exceeded, use an Airflow-control Setting that results in an airflow not greater than 55 scfm per 1000 Btu/h.

If the Nominal Capacity of each Indoor Unit is not accessible, then use total airflow and system Rated Capacity to determine the maximum allowable airflow rate.

If multiple Indoor Units discharge to a common duct, the cooling airflow limit is the lower of either the sum of nominal cooling capacities at 55 scfm per 1000 Btu/h or 105% of the sum of nominal airflows as published in product literature. When using the same Airflow-control Setting as cooling, the heating airflow does not have a maximum limit. If the Airflow-control Settings are different from cooling, the maximum limit is the sum of nominal cooling capacities at 55 scfm per 1000 Btu/h. These limits include all Indoor Units connected to the common duct and apply to the total airflow measured for all Indoor Units connected to the common duct.

The grouping of indoor units shall be manufacturer specified. However, if the manufacturer specifications do not consist of this grouping, any grouping of the specified indoor unit models connected to common ducts can be used, provided all test standard provisions are met.

6.3.1.4 *Maximum Airflow for Ducted Indoor Units.* The same restrictions in Section 6.3.1.3 for Non-ducted Indoor Units apply to Ducted Indoor Units, except 42 scfm per 1000 Btu/h shall be used instead of 55 scfm per 1000 Btu/h.

6.3.1.5 *Tolerances.* If a common duct is used for the combined discharge airflow of multiple Indoor Units, the measured combined airflow shall be compared to the sum of the airflow target value as defined in Section 6.3.1.2. In such a case, the following airflow tolerances apply to the measured combined discharge airflow.

6.3.1.5.1 *Condition Tolerances.* All tolerances for airflow and ESP specified in this section for setting airflow and ESP apply throughout each test. The average value of a parameter measured over

the course of the test shall not vary from the target value by more than the condition tolerance specified in Table 12.

6.3.1.5.2 *Non-Ducted Indoor Units.*

6.3.1.5.2.1 Use the airflow target values defined in Section 6.3.1.2 for each respective test.

6.3.1.5.2.2 For all tests, conduct the test at zero ESP with a tolerance of -0.00 to $+0.02$ in H_2O .

6.3.1.5.2.3 For the full-load cooling test, the airflow tolerance is $\pm 5\%$ of target full-load cooling airflow. For the heating test, if the full-load cooling airflow is used or the target heating airflow is provided, the airflow tolerance is $\pm 5\%$ of the target airflow. If the manufacturer provides instructions to obtain steady-state heating operation in accordance with Section 6.3.1.2.2, an airflow tolerance is not required for the heating test. For part-load cooling tests, if the full-load cooling airflow is used or the target part-load cooling airflow is provided, the airflow tolerance is $\pm 5\%$ of the target airflow. If the manufacturer provides instructions to obtain steady-state part-load cooling operation in accordance with Section 6.3.1.2.3, an airflow tolerance is not required for part-load cooling tests.

6.3.1.5.2.4 If both the ESP and airflow cannot be maintained within tolerance for the full-load cooling and heating tests, maintain the ESP within the required tolerance and use an airflow as close to the target value as can be achieved.

6.3.1.5.3 *Ducted Indoor Units.*

6.3.1.5.3.1 *Full-Load Cooling Test.*

6.3.1.5.3.1.1 Operate the unit under conditions specified for the full-load cooling test using the airflow target value specified in Section 6.3.1.2. Adjust the airflow-measuring apparatus to maintain ESP within -0.00 to $+0.05$ in H_2O of the requirement specified in Table 6 or to maintain the airflow within $\pm 5\%$ of the full-load cooling airflow target value.

If both the ESP and airflow cannot be maintained within tolerance for the full-load cooling test, maintain the ESP within the required tolerance and use an airflow as close to the manufacturer-specified value as can be achieved.

6.3.1.5.3.2 *Heating Test.*

6.3.1.5.3.2.1 If the manufacturer-specified heating Airflow-control Setting is the same as the manufacturer-specified full-load cooling Airflow-control Setting, or if a heating Airflow-control Setting is not specified and the specified full-load cooling airflow target value is used as the airflow for the test in accordance with the provisions of Section 6.3.1.2.2, use the Airflow-control Settings used for the full-load cooling test. Adjust the airflow-measuring apparatus to maintain the airflow within $\pm 5\%$ of the measured full-load cooling airflow without regard to the resulting ESP.

6.3.1.5.3.2.2 If the manufacturer-specified heating Airflow-control Setting differs from the manufacturer-specified full-load cooling Airflow-control Setting (or if a heating Airflow-control Setting is not specified and the full-load cooling delivered airflow differs from the part-load test at the same Airflow-control Setting, in accordance with the provisions of Section 6.3.1.2.2), use the following provisions.

6.3.1.5.3.2.2.1 Operate the unit under conditions specified for the heating test using the airflow target value specified in Section 6.3.1.2 for the heating test.

6.3.1.5.3.2.2.2 Adjust the airflow-measuring apparatus to maintain ESP within -0.00 to +0.05 in H₂O of the adjusted ESP requirement calculated by Equation 2 and maintain airflow within ±5% of the manufacturer-specified heating airflow.

6.3.1.5.3.2.2.3 If both the ESP and airflow cannot be maintained within tolerance for the heating tests, maintain the ESP within the required tolerance and use an airflow as close to the manufacturer-specified value as can be achieved.

6.3.1.5.3.3 *Part-load Cooling Tests.*

6.3.1.5.3.3.1 If the manufacturer-specified part-load cooling airflow is the same as the manufacturer-specified full-load cooling airflow, or if a part-load cooling airflow is not specified and the specified full-load cooling airflow target value is used as the airflow for the test in accordance with the provisions of Section 6.3.1.2.3, use the Airflow-control Settings used for the full-load cooling test. Adjust the airflow-measuring apparatus to maintain the airflow within ±5% of the measured full-load cooling airflow without regard to the resulting ESP. Changes shall not be made to the Airflow-control Settings for the part-load cooling tests.

For part-load cooling tests when an airflow is not specified and the specified full-load cooling airflow target value is not used as the airflow for the test because the delivered airflow differs from the part-load at the same Airflow-control Setting in accordance with Section 6.3.1.2.3, adjust the airflow-measuring apparatus to meet the adjusted ESP requirement determined by Equation 2 with a condition tolerance of -0.00 to +0.05 in H₂O, using the measured part-load cooling airflow in the ESP calculation.

6.3.1.5.3.3.2 If the manufacturer-specified part-load cooling airflow differs from the manufacturer-specified full-load cooling airflow, use the following provisions.

6.3.1.5.3.3.2.1 Operate the system under conditions specified for the part-load cooling test using the manufacturer-specified Airflow-control Settings for the full-load cooling test.

6.3.1.5.3.3.2.2 Adjust the airflow measuring apparatus to maintain ESP within -0.00 to +0.05 in H₂O of the adjusted ESP requirement calculated using Equation 2 and maintain airflow within ±5% of the manufacturer-specified part-load cooling airflow.

6.3.1.5.3.3.2.3 If both the ESP and airflow cannot be maintained within tolerance for the part-load cooling tests, maintain the ESP within the required tolerance and use an airflow as close to the manufacturer-specified value as can be achieved.

Table 8. Operating Conditions for Standard Rating and Performance Operating Tests for VRF Air-Source Systems

Test Name		Indoor Section Air Entering		Outdoor Section Air Entering	
		Dry-Bulb, °F	Wet-Bulb, °F	Dry-Bulb, °F	Wet-Bulb, °F
COOLING	Standard Rating Conditions Cooling	80.0	67.0	95.0	N/A
	Low Temperature Operating Cooling ¹	67.0	57.0	67.0	N/A
	Maximum Operating Conditions ²	80.0	67.0	115	N/A
	Standard Rating Part-Load Conditions (IEER) ²	80.0	67.0	81.5 (75% Load) 68.0 (50% Load) 65.0 (25% Load)	N/A
	Insulation Effectiveness	80.0	75.0	80.0	N/A
	Condensate Disposal	80.0	75.0	80.0	N/A
HEATING	Standard Rating Conditions (High Temperature Steady-state Test for Heating)	70.0	60.0 (maximum)	47.0	43.0
	Standard Rating Conditions (Low Temperature Steady-state Test for Heating)	70.0	60.0 (maximum)	17.0	15.0
	Maximum Operating Conditions	80.0	N/A	5.0	65.0

Notes:

- Refer to Section 6.3.3.2 for SHR limits on 100% and 75% load test points.
- 1. Cooling rating and operating tests are not required for heating only Heat Pumps.
- 2. For indoor and outdoor airflow requirements, refer to Section 6.3.1 and Section 6.3.2, respectively.

6.3.2 Outdoor-Coil Airflow Rate (Referred to as outdoor fan speed) (Applies to VRF Air-source Systems Only). All Standard Ratings shall be determined at the outdoor-coil airflow rate achieved at zero external static pressure. Where the fan drive is non-adjustable, all Standard Ratings shall be determined at the outdoor-coil airflow rate inherent in the equipment when operated with all resistance elements associated with inlets, louvers, and any ductwork and attachments shipped with the unit or as specified in MII. For adjustable speed fans, the outdoor fan speed shall be set as specified by the STI and within the range defined by Appendix C. If instructions are not provided, follow the hierarchy described in Section 5.1.2.2 for Control Setting(s). Once established, the outdoor-side air circuit of the equipment shall remain unchanged throughout all tests prescribed herein unless automatic adjustment of outdoor airflow rates by system function is made.

6.3.3 Allowable Critical Parameter Adjustments. The following sections describe Critical Parameter adjustments performed by lab personnel allowed for meeting part-load capacity targets and SHR limits. For Steady-state Tests conducted in a third-party laboratory, the use of proprietary tools by a manufacturer’s representative can be used to set Critical Parameters under the supervision of the third-party laboratory, using the Service Tool to monitor Critical Parameters.

6.3.3.1 Critical Parameter Adjustments for Meeting Cooling Capacity Targets. Once Critical Parameters have been set to the values in the STI, if the unit cannot operate within 3% of the target cooling capacity, that is within 3% of the load fraction for a given part-load cooling test (75%, 50%, or 25% load) or within 3% of the cooling capacity for a 100% full-load cooling test, manually controlled critical parameters shall be adjusted according to the provisions in Section 6.3.3.1.1 and Section 6.3.3.1.2:

6.3.3.1.1 Cooling Capacity is Below Lower Tolerance. If, for any test, the cooling capacity operates below the lower tolerance for the target cooling capacity, increase the compressor speed(s) beyond the STI value(s) until the cooling capacity operates within 3% of the target cooling capacity. If multiple compressors are present in the system, increase compressor speed by the same absolute increment in RPM or Hz for each

compressor when both of the following conditions apply:

- The STI specifies a non-zero compressor speed for the compressor for that test, and
- The compressor has not yet reached the maximum capable operating speed.

The compressor speed(s) shall not be less than the STI value(s) at any point during the test. Upward adjustments to compressor speed are not constrained by a budget on RSS Points Total.

6.3.3.1.2 Cooling Capacity is Above Upper Tolerance. If, for any test, the cooling capacity operates above the upper tolerance for the target cooling capacity, adjust any manually controlled critical parameters in accordance with the STI. If the STI does not include a hierarchy of instructions for adjustment of critical parameters to reduce cooling capacity during IEER cooling tests, then reduce only the compressor speed(s) to reduce cooling capacity. If multiple compressors are present in the system, decrease compressor speed by the same absolute increment for each compressor when both of the following conditions apply:

- The STI specifies a non-zero compressor speed for the compressor for that test, and
- The compressor has not yet reached minimum speed.

Continue reducing cooling capacity in this manner until one of the following occurs:

- The unit operates within 3% of the target cooling capacity; or
- The RSS point total reaches a budget of seventy points. For the 75%, 50% and 25% part-load cooling test points, if the RSS point total reaches seventy during critical parameter adjustments before the capacity operates within 3% of the target cooling capacity, stop adjustment and follow cyclic degradation procedures in accordance with Section 11.2.2.1.

Note: Refer to Appendix H for example calculations for critical parameter budget method

6.3.3.1.2.1 Measuring Critical Parameter Variation During Adjustment Period. When adjusting critical parameters to reduce cooling capacity, the critical parameter variation shall be calculated each time the critical parameters are adjusted by using Equation C3 through Equation C5 and Table C3, while replacing “measured Critical Parameter value ($CP_{i,t}$)” with “adjusted Critical Parameter value ($CP_{i,Adj}$).”

6.3.3.2 Critical Parameter Adjustments for Meeting SHR Limits. The SHR for the 100% load test point and the 75% part-load test point shall not be higher than 0.82 and 0.85, respectively, measured to the nearest hundredth. If the SHR is above the allowable limit, increase the compressor speed(s) until either the SHR is less than or equal to the allowable limit or the cooling capacity reaches 3% greater than the target cooling capacity for that test, whichever happens first. If multiple compressors are present in the system, increase compressor speed by the same absolute increment for each compressor when both of the following conditions apply:

- The STI specifies a non-zero compressor speed for the compressor for that test, and
- The compressor has not yet reached maximum speed.

Upwards adjustments to compressor speed are not constrained by a budget on RSS Points Total. If the SHR remains above the maximum limit when the cooling capacity reaches the upper 3% tolerance, further compressor adjustments shall not be made, and the calculation procedures specified in Section 11.2.2.2 shall be applied using the adjusted SHR value obtained after increasing the compressor speed(s).

6.4 Conditions for VRF Water-source Heat Pumps.

6.4.1 Power Input of Liquid Pumps.

6.4.1.1 If a liquid pump is not provided with the Heat Pump, a pump power adjustment is to be included in the Total Power consumed by the Heat Pump by using Equation 3.

$$\varphi_{pa} = \frac{q \times \Delta p_{int}}{\eta}$$

3

6.4.1.2 If a liquid pump is an integral part of the Heat Pump, only the portion of the pump power required to overcome the internal resistance shall be included in the Total Power to the Heat Pump. The fraction that is to be excluded from the Total Power consumed by the pump shall be calculated using Equation 4.

$$\varphi_{pa} = \frac{q \times \Delta p_{ext}}{\eta}$$

6.4.2 *Liquid Flow Rates.*

6.4.2.1 All Standard Ratings shall be determined at a liquid flow rate described below, expressed as gpm.

6.4.2.2 VRF Water-source Heat Pumps with integral liquid pumps shall be tested at the liquid flow rates specified by the manufacturer or those obtained at zero external static pressure difference, whichever provides the lower liquid flow rate.

6.4.2.3 Systems without integral liquid pumps shall be tested at the flow rates specified by the manufacturer.

6.4.2.4 The manufacturer shall specify a single liquid flow rate for all tests required in Section 6.4 with a maximum limit of four gpm per 12,000 Btu/h of Standard Rating Cooling Capacity. Automatic adjustment provided by the equipment to reduce the liquid flow rate from the flow for the full load cooling test can be used. A separate control signal output for each step of liquid flow rate shall be designated as an automatic adjustment.

6.4.3 *Test Liquids.*

6.4.3.1 The test liquid for Water Loop Heat Pumps and Ground-water Heat Pumps shall be water.

6.4.3.2 The test liquid for Ground-loop Heat Pumps shall be a 15% solution by mass of ethylene glycol in water.

6.4.3.3 The test liquid shall be free of gas to verify that the measured result is not influenced by the presence of gas.

6.4.4 *Standard Rating and Part-load Rating Test Conditions.*

6.4.4.1 The test conditions for the determination of Standard Rating Conditions and part-load rating cooling conditions are specified in Table 9.

6.4.4.2 The test conditions for determination of Standard Rating Conditions and part-load rating heating conditions are specified in Table 10.

6.4.4.3 Systems intended for a specific application shall be rated at the conditions specified for that application as identified in Section 7.3 of AHRI 600.

6.4.4.4 Allowable adjustments to Critical Parameters are specified in Section 6.3.3.

6.4.4.5 Airflow-control Settings shall be in accordance with Section 6.3.1. Liquid flow rate conditions shall be in accordance with Section 6.4.2.

6.4.5 *Part-load Rating Conditions.* Test conditions for part-load ratings shall be in accordance with Table 9. Any water flow required for system function shall be at water flow rates established at (full load) Standard Rating Cooling Capacity Conditions, except as required by Section 6.4.4. If the unit cannot operate within 3% of the target load fraction for a given part-load test point (75%, 50%, or 25%), follow the provisions of Section 6.3.3.

Table 9. Operating Conditions for Standard Rating and Performance Operating Tests for the Determination of Cooling Capacity for VRF Water-source Heat Pumps			
—	Water-loop² Heat Pumps °F	Ground-water² Heat Pumps °F	Ground-loop² Heat Pumps °F
Air entering indoor side			
— dry bulb	80.6	80.6	80.6
— wet bulb	66.2	66.2	66.2
Air surrounding Outdoor Unit			
— dry bulb	80.6	80.6	80.6
<u>Standard Rating Test</u>			
Liquid entering heat exchanger	86.0	59.0	77.0
<u>Part-load Conditions (IEER)</u>			
Liquid entering heat exchanger ¹	86 (100% Load) 81.0 (75% Load) 74.0 (50% Load) 67.0 (25% Load)	59.0	68.0
Insulation Effectiveness			
— dry bulb	80.6	80.6	80.6
— wet bulb	75.2	75.2	75.2
— liquid entering heat exchanger	68.0	50.0	50.0
Condensate Disposal			
— dry bulb	80.6	80.6	80.6
— wet bulb	75.2	75.2	75.2
— liquid entering heat exchanger	68.0	50.0	50.0
Voltage, V	Rated	Rated	Rated
Note:			
<ul style="list-style-type: none"> • Refer to Section 6.3.3.2 for SHR limits on 100% and 75% load test points. 2. Water-Loop is Condition C1, Ground-water is Condition C2 and Ground-loop is Condition C3 from AHRI 600 			

Table 10. Conditions for Standard Rating for the Determination of Heating Capacity for Systems that use a VRF Water-source Heat Pump Systems			
—	Water-Loop Heat Pumps °F	Ground-water Heat Pumps °F	Ground-loop Heat Pumps °F
Air entering indoor side ¹			
— dry bulb	68.0	68.0	68.0
— maximum wet bulb	59.0	59.0	59.0
Air surrounding Outdoor Unit			
— dry bulb	68.0	68.0	68.0
<u>Standard Rating Test</u>			
Liquid entering heat exchanger	68.0	50.0	32.0
Voltage, V	Rated	Rated	Rated

6.5 Simultaneous Cooling and Heating Efficiency and Capacity Ratings (Applicable to all VRF Heat Recovery Systems).

6.5.1 General Conditions.

6.5.1.1 All VRF Heat Recovery Systems shall have Simultaneous Cooling and Heating Efficiencies (SCHEs) determined in accordance with the provisions of this standard. All tests shall be carried out in accordance with Section 5, except 5.1.2.1 is not applicable.

6.5.1.2 All Indoor Units of the selected Tested Combination shall be operating during this test. For the purposes of the simultaneous operation testing, the Nominal Cooling Capacity of the Indoor Units shall be split between the heating and cooling test rooms and as close to 50% as can be achieved. The split ratio of the Nominal Cooling Capacity between units operating in heating and cooling shall be between 45% and 55%.

6.5.1.3 During the SCHE test, the room that has the higher nominal Indoor Unit capacity shall be in cooling mode. The manufacturer shall adjust the compressor speed to operate at 50% of the Standard Rating Cooling Capacity as the minimum used for the cooling capacity for the SCHE test.

Note: The heating side capacity should correspondingly be 45% or greater of the Standard Rating Cooling Capacity.

6.5.2 Temperature Conditions. The air temperature conditions shall be as stated in Table 11. For water-source heat pumps, the entering liquid heat exchanger temperatures in Table 10 shall be used for SCHE testing.

Table 11. Simultaneous Heating and Cooling Test Conditions				
	Three Room Air Enthalpy		Two Room Air Enthalpy	
	Dry bulb, °F	Wet bulb, °F	Dry bulb, °F	Wet bulb, °F
Outdoor Air				
- Air-source	47.0	43.0	47.0	43.0
- Water-source	68.0	—	68.0	—
Indoor Air (Air-source)				
- Heating	70.0	60.0 ¹	75.0	63.6
- Cooling	80.0	67.0	75.0	63.6
Indoor Air (Water-source)				
- Heating	68.0	59.0 ¹	74.3	62.7
- Cooling	80.6	66.2	74.3	62.7
Note:				
1. Maximum value				

6.5.3 Air-flow Conditions. The test shall be conducted at the same Airflow-control Setting as full-load heating and cooling tests. If the cooling full-load airflow rate is different than the heating full-load airflow rate, units operating in cooling mode shall be set at the cooling full-load airflow rate and units operating in heating mode shall be set at the heating full-load airflow rate.

6.5.4 Test Conditions.

6.5.4.1 Preconditions. The test room reconditioning apparatus and the equipment under test shall be operated until equilibrium conditions are attained, but for not less than one hour, before data is recorded.

6.5.4.2 Duration of Test. Data shall be recorded for thirty minutes at least every five minutes for at least seven consecutive readings within the tolerances presented in Table 2A of ASHRAE 37.

6.5.5 Three-room Air Enthalpy Method.

6.5.5.1 The Indoor Units in the cooling mode shall be assembled in one room and the Indoor Units in the heating mode in another room. The Outdoor Unit shall be installed in the third room.

6.5.6 Two-room Air Enthalpy Method.

6.5.6.1 All Indoor Units, either operating in cooling or heating mode, are assembled in one indoor room. The Outdoor Unit shall be installed in the other room.

6.5.6.2 All Indoor Units operating in the heating mode shall be connected to a common plenum, and all Indoor Units operating in the cooling mode shall be connected to another common plenum, both in accordance with the requirements established in the Indoor air enthalpy test method described in ASHRAE 37.

6.5.7 When testing set up is done using two indoor rooms with total capacity of Indoor Units being 50% in each room, the SCHE shall be calculated using Equation 5. When testing set up is done using three indoor rooms with total combined capacity of Indoor Units being 50% heating in heating indoor room 1 and a total combined capacity of Indoor Units being 50% cooling in cooling indoor room 1 and cooling indoor room 2, the SCHE shall be calculated using Equation 6.

$$SCHE = \frac{\dot{q}_{thir1} + \dot{q}_{tcir1}}{\dot{E}_{tot}} \tag{5}$$

$$SCHE = \frac{\dot{q}_{thir1} + \dot{q}_{tcir1} + \dot{q}_{tcir2}}{\dot{E}_{tot}} \tag{6}$$

6.6 Test Tolerances. Test Operating Tolerances and Test Condition Tolerances for Steady-state Tests shall be as specified in Table 12, superseding values specified in Table 2b of ASHRAE 37. The difference between the maximum and minimum sampled values shall be less than or equal to the specified Test Operating Tolerance.

For the saturated refrigerant temperature corresponding to the measured indoor side pressure, the tolerance in Table 12 applies only for the compressor calibration and refrigerant enthalpy methods. The saturation temperature, in this case, shall be evaluated based on the pressure transducer located between the indoor coil and the compressor for the given operating mode, heating or cooling.

Measurement		Test Operating Tolerance	Test Condition Tolerance
Outdoor dry-bulb temperature, °F:			
Entering		2.0	0.5
Leaving		2.0 / 3.0 ^{1,3}	—
Outdoor wet-bulb temperature, °F:			
Entering		1.0	0.3 ²
Leaving		1.0 ³	—
Indoor dry-bulb temperature, °F:			
Entering		2.0	0.5 ⁴
Leaving		2.0 / 3.0 ^{1,4}	0.5 ⁴
Indoor wet-bulb temperature, °F:			
Entering		1.8	0.36
Leaving		1.0	—
Saturated refrigerant temperature corresponding to the measured indoor side pressure ⁵ , °F		3.0	0.5
Liquid temperature if not otherwise specified, °F		0.9	0.36
External static pressure	Non-ducted Indoor Units, in H ₂ O	0.04	0.02
	Ducted Indoor Units (percent of reading) ⁶	10	See Table 6
Electrical voltage (percent of reading) ⁶		2.0	1.0
Liquid flow rate (percent of reading) ⁶		2.0	1.0
Nozzle pressure drop (percent of reading) ⁶		5.0	—
Notes:			
1. The Test Operating Tolerance is 2.0°F for cooling tests and 3.0°F for heating tests.			
2. Applies only for heating tests of VRF Air-source Systems.			
3. Applies only when using the outdoor air enthalpy method.			
4. Applies only when using the indoor air enthalpy method.			
6. For tolerances expressed as a percentage, the tolerance is the specified percentage of the average value of the measured test parameter.			

Section 7. Determination of Published Ratings

7.1 Standard Ratings Values. Standard Ratings relating to cooling or heating capacities shall be net values including the effects of circulating-fan heat but not including supplementary heat such as disabling resistance elements used for heating indoor air at all times. Power input shall be the sum of power inputs to the compressor(s) and fan(s), plus System Controls and other items required as part of the system for normal operation.

7.1.1 Values of Full System Rated Capacity. These ratings shall be expressed only in terms of Btu/h, rounded as shown in Table 13.

Table 13. Values of Full System Rated Capacity	
Rated Capacity Btu/h	Multiples Btu/h
< 20,000	100
≥ 20,000 and < 38,000	200
≥ 38,000 and < 65,000	500
≥ 65,000 and < 135,000	1000
≥ 135,000	2000

7.1.2 Values of Energy Efficiency for VRF Air-source Systems and VRF Water-source Heat Pump Systems. Energy Efficiency Ratios (EER), and Integrated Energy Efficiency Ratios (IEER) for cooling, whenever published shall be expressed in multiples of the nearest 0.1 (Btu/h)/W. SCHE and COP shall be expressed in multiples of the nearest 0.01.

7.2 Ratings. Standard Ratings for capacity, EER_{A, Full}, IEER, and COP_H shall be established either on test data in accordance with Section 7.2.1 or by computer simulation.

7.2.1 Ratings Generated by Test Data. Any capacity, EER_{A, Full}, IEER, or COP_H rating of a system generated by test data shall be based on the results of at least two unique production or production representative samples tested in accordance with all applicable portions of this standard. The capacity, EER_{A, Full}, COP_H, or IEER ratings shall not be greater than the lower of a) the test sample mean (\bar{x}), or b) the lower 95% confidence limit (LCL) divided by 0.95 as defined by Equation 7, Equation 8, and Table 14, rounded in accordance with Section 7.1.1 and Section 7.1.2. Equation 7 and Equation 8 are example calculations for LCL:

$$\bar{x} = \frac{\sum_{i=1}^n x_i}{n} \tag{7}$$

$$LCL = \bar{x} - t_{.95} \left(\frac{s}{\sqrt{n}} \right) \tag{8}$$

Table 14. Statistics	
Number of Systems Tested ¹	$t_{.95}$
2	6.314
3	2.920
4	2.353
5	2.132
6	2.015
Note: 1. From Appendix A of Subpart B of 10 CFR §429	

7.2.2 Mixed Ratings. Mixed Ratings shall be determined by the straight average of two individual systems represented (rated) values containing homogenous kinds of Indoor Units such as non-ducted, ducted, or SDHV.

7.2.3 Documentation. As required by 10 CFR §429.71, supporting documentation of all Published Ratings subject to federal control shall be maintained.

7.2.4 Multiple Standard Ratings. A single product can have more than one Standard Rating. If multiple Standard Ratings exist, the conditions for each Standard Rating shall be clearly identified for each individual Standard Rating.

7.2.5 Ducted and Non-ducted Combinations.

7.2.5.1 For manufacturers that offer either only non-ducted combinations or only ducted combinations, ratings shall be determined by testing at least two complete system samples of the same combination of Indoor Units.

7.2.5.1.1 For any system combinations using only Non-ducted Indoor Units that meet the definition of a Tested Combination, the rating given to any untested VRF System combination having the same Outdoor Unit and all Non-ducted Indoor Units shall be set equal to the rating of the tested system having all Non-ducted Indoor Units.

7.2.5.1.2 For any system combinations using only Ducted Indoor Units that meet the definition of a Tested Combination, the rating given to any untested VRF System combination having the same Outdoor Unit and all Ducted Indoor Units shall be set equal to the rating of the tested system having all Ducted Indoor Units. To be designated a Ducted Indoor Unit, the Indoor Unit shall be intended to be connected to ductwork and have a rated external static pressure capability greater than zero.

7.2.5.2 For manufacturers that offer both non-ducted combinations and ducted combinations, ratings shall be determined by testing two or more combinations of Indoor Units with each Outdoor Unit with one combination consisting of only Non-ducted Indoor Units and the second consisting of only Ducted Indoor Units.

7.2.5.2.1 For any system combinations using only Non-ducted Indoor Units that meet the definition of a Tested Combination, the rating given to any untested VRF System combination having the same Outdoor Unit and all Non-ducted Indoor Units shall be set equal to the rating of the tested system having all Non-ducted Indoor Units.

7.2.5.2.2 For any system combinations using only Ducted Indoor Units that meet the definition of a Tested Combination, the rating given to any untested VRF System combination having the same Outdoor Unit and all Ducted Indoor Units shall be set equal to the rating of the tested system having all ducted Indoor Units. To be designated a Ducted Indoor Unit, the Indoor Unit shall be intended to be connected to ductwork and have a rated external static pressure capability greater than zero.

7.2.5.2.3 The rating given to any untested VRF System combination having the same Outdoor Unit and a mix of non-ducted and ducted Indoor Units shall be set equal to the average of the ratings for the two required Tested Combinations.

7.2.6 System Compatible with Multiple Refrigerants. If a Basic Model is distributed in commerce and approved for use with multiple refrigerants, a manufacturer shall determine all represented values for that Basic Model, for example, IEER, COP, cooling capacity, and heating capacity, based on the refrigerant that results in the lowest cooling efficiency. A refrigerant is approved for use if the refrigerant is listed on the nameplate of the outdoor unit.

Section 8. Operating Requirements

8.1 Operating Requirements. Systems shall comply with the provisions of this section such that any production unit meets the requirements detailed herein.

8.1.1 Voltage Tolerance Test. Systems shall pass the following voltage tolerance test with a cooling coil airflow rate as determined under Section 6.

8.1.1.1 Temperature Conditions. Temperature conditions shall be maintained as required at the standard cooling or standard heating, or both. Steady state conditions as shown in Table 8 or Table 9, as applicable, in accordance with the unit's nameplate. For equipment marked for application at more than one Standard Rating condition, the strictest outdoor ambient conditions shall be used.

8.1.1.2 *Voltages.*

8.1.1.2.1 *Steady state.* Two separate tests shall be performed, one test at the Range B minimum utilization voltage and one test at the Range B maximum utilization voltage from Table 1 of AHRI 110, based upon the unit’s nameplate rated voltage(s). These voltages shall be supplied at the unit’s service connection and at rated frequency. A lower minimum or a higher maximum voltage shall be used, if listed on the nameplate.

8.1.1.2.2 *Power Interrupt.* During the power interrupt portion of each test, the voltage supplied to the equipment (single phase and three phase) shall be adjusted just prior to the shut-down period such that the resulting voltage at the unit’s service connection is 86% of nameplate rated voltage when the compressor motor is on locked-rotor. (For 200V or 208V nameplate rated equipment the restart voltage shall be set at 180V when the compressor motor is on locked rotor). Open circuit voltage for three-phase equipment shall not be greater than 90% of nameplate rated voltage.

8.1.1.2.3 *Resume Operation.* During the resume operation portion of the test, the voltage supplied to the equipment shall be the same as the voltage in accordance with Section 8.1.1.2.1.

8.1.1.3 *Procedure.*

8.1.1.3.1 *Steady state.* The equipment shall be operated for one hour at the temperature conditions and each voltage specified in 8.1.1.1 and 8.1.1.2.

8.1.1.3.2 *Power Interrupt.* All power to the equipment shall be shut off for a period long enough to cause the compressor to stop (not to exceed five seconds) and then immediately restored.

8.1.1.3.3 *Resume Operation.* Within one minute after the equipment has resumed continuous operation, the voltage shall be restored to the values specified in Section 8.1.1.2.1. During the remainder of the resume operations phase, voltage and temperature conditions shall be retained as specified in Section 8.1.1.3.1. Refer to Figure 2.

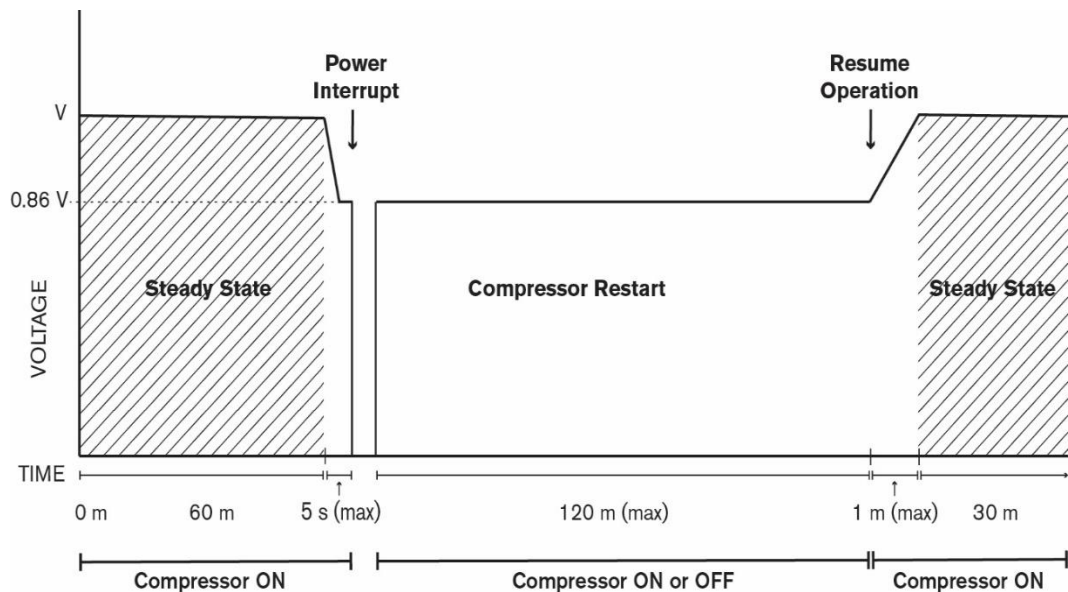

Figure 2. Voltage Tolerance Test Power Interrupt Procedure

8.1.1.4 *Requirements.*

8.1.1.4.1 During the entire test, the equipment shall operate without failure of any of its parts.

8.1.1.4.2 *Steady state.* During the steady state portion of the test, the equipment shall operate continuously without interruption for any reason.

8.1.1.4.3 *Resume Operation.* During the resume operation portion of the test, the unit shall resume continuous operation within two hours of restoration of power and shall then operate continuously for one half hour. Units can automatically reset safety devices prior to re-establishment of continuous operation.

8.1.2 *Operating Requirements for VRF Air-source Systems.*

8.1.2.1 *Maximum Operating Conditions Test (Cooling and Heating).* VRF Systems shall pass the following maximum cooling and heating operating conditions test with an indoor coil airflow rate as determined under Section 6.

8.1.2.1.1 *Temperature Conditions.* Temperature conditions shall be maintained as shown in Table 8, as applicable, in accordance with the unit's nameplate.

8.1.2.1.2 *Voltages.* Tests shall be run at the minimum and maximum utilization voltages of Voltage Range B as shown in Table 1 of AHRI 110, at the unit's service connection and at rated frequency.

8.1.2.1.3 *Procedure.*

8.1.2.1.3.1 VRF Systems shall be operated continuously for one hour at the temperature conditions and voltage(s) specified.

8.1.2.1.3.2 All power to the system shall be interrupted for a period long enough to cause the compressor(s) to stop (not to exceed five seconds) and then be restored.

8.1.2.1.4 *Requirements.*

8.1.2.1.4.1 During both tests, the VRF Systems shall operate without failure of any of its parts.

8.1.2.1.4.2 The unit shall resume continuous operation within one hour of restoration of power and shall then operate continuously for one hour. Units can automatically reset safety devices prior to re-establishment of continuous operation.**8.1.2.2** *Maximum Operating Conditions Test for Equipment with Optional Outdoor Cooling Coil.* VRF Systems that incorporate an outdoor air cooling coil shall use the conditions, voltages, and procedure (Section 8.1.2.1.1 through Section 8.1.2.1.4) and meet the requirements of Section 8.1.1.2 except for the following:

- Outdoor air set as in Section 6;
- Indoor return air temperature conditions shall be 80.0°F dry-bulb and 67.0°F wet-bulb; and
- Outdoor air entering outdoor air cooling coil shall be 115°F dry-bulb and 75.0°F wet-bulb.

8.1.2.3 *Cooling Low Temperature Operation Test.* VRF Systems shall pass the following low-temperature operation test when operating with initial airflow rates as determined in Section 6, and with System Controls and dampers set to produce the maximum tendency to frost or ice the indoor coil, provided such settings are not contrary to the MII.

8.1.2.3.1 *Temperature Conditions.* Temperature conditions shall be maintained as shown in Table 8, as applicable, in accordance with the unit's nameplate.

8.1.2.3.2 *Voltage and Frequency.* The test shall be performed at nameplate rated voltage and frequency.

For air-conditioners and Heat Pumps with dual nameplate voltage ratings, tests shall be performed at the lower of the two voltages.

8.1.2.3.3 Procedure. The test shall be continuous with the unit in the cooling cycle for not less than four hours after establishment of the specified temperature conditions. The unit can be started and stopped under control of an automatic limit device, if provided.

8.1.2.3.4 Requirements.

8.1.2.3.4.1 During the entire test, the VRF Systems shall operate without damage to the equipment.

8.1.2.3.4.2 During the entire test, the indoor airflow rate shall not drop more than 25% from that specified for the Standard Rating Conditions Cooling test.

8.1.2.3.4.3 During all phases of the test and during the defrosting period after the completion of the test, all ice or meltage shall be caught and removed by the drain provisions.

8.1.2.4 Insulation Effectiveness Test (Cooling). VRF Systems shall pass the insulation effectiveness test outlined in Section 8.1.2.4.1 through Section 8.1.2.4.3 when operating with airflow rates as determined in Section 6, and with System Controls, fans, dampers, and grilles set to produce the maximum tendency to sweat, provided such settings are not contrary to the MII.

8.1.2.4.1 Temperature Conditions. Temperature conditions shall be maintained as shown in Table 8, as applicable, in accordance with the unit's nameplate.

8.1.2.4.2 Procedure. After establishment of the specified temperature conditions, the unit shall be operated continuously for a period of four hours.

8.1.2.4.3 Requirements. During the test, condensed water shall not drip, run off, or blow off from the unit casing.

8.1.2.5 Condensate Disposal Test (Cooling). VRF Systems that reject condensate to the condenser air shall pass the condensate disposal test outlined in Section 8.1.2.5.1 through Section 8.1.2.5.3 when operating with airflow rates as determined in Section 6, and with System Controls and dampers set to produce condensate at the maximum rate, provided such settings are not contrary to the MII. This test can be run concurrently with the insulation effectiveness test outlined in Section 8.1.2.4.

8.1.2.5.1 Temperature Conditions. Temperature conditions shall be maintained as shown in Table 9, as applicable, in accordance with the unit's nameplate.

8.1.2.5.2 Procedure. After establishment of the specified temperature conditions, the equipment shall be started with its condensate collection pan filled to the overflowing point and shall be operated continuously for four hours after the condensate level has reached equilibrium.

8.1.2.5.3 Requirements. During the test, dripping, running-off, or blowing-off of moisture from the unit casing shall not occur.

8.1.3 Operating Requirements for VRF Water-source Heat Pumps.

8.1.3.1 Capacity Requirements.

8.1.3.1.1 For VRF Water-source Heat Pumps with capacity control, the performance requirements tests shall be conducted at maximum capacity.

8.1.3.2 Maximum Operating Conditions Test.

8.1.3.2.1 Test conditions. The maximum operating conditions tests shall be conducted for cooling and heating at the test conditions established for the specific applications specified in Table 15 and

Table 16. VRF Water-source Heat Pumps intended for use in two or more applications shall be tested at the strictest set of conditions specified in Table 15 and Table 16.

Units with VRF Water-source condensers shall be capable of operation under these maximum conditions at a water-pressure drop not to exceed 15.0 psid, measured across the unit.

8.1.3.2.2 *Test Procedures.*

8.1.3.2.2.1 The equipment shall be operated continuously for one hour after the specified temperatures have been established at each specified voltage level.

8.1.3.2.2.2 The 110% voltage test shall be conducted prior to the 90% voltage test.

8.1.3.2.2.3 All power to the equipment shall be interrupted for three minutes at the conclusion of the one-hour test at the 90% voltage level and then restored for one hour.

	Water-loop Heat Pumps	Ground-water Heat Pumps	Ground-loop Heat Pumps
Air entering indoor side			
— dry bulb, °F	89.6	89.6	89.6
— wet bulb, °F	73.4	73.4	73.4
Air surrounding unit			
— dry bulb, °F	89.6	89.6	89.6
Liquid entering heat exchanger, °F	104	77.0	104
Frequency, Hz	Rated	Rated	Rated
Voltage, V	1. 90% and 110% of rated voltage for equipment with a single nameplate rating. 2. 90% of minimum voltage and 110% of maximum voltage for equipment with dual nameplate voltage.	1. 90% and 110% of rated voltage for equipment with a single nameplate rating. 2. 90% of minimum voltage and 110% of maximum voltage for equipment with dual nameplate voltage.	1. 90% and 110% of rated voltage for equipment with a single nameplate rating. 2. 90% of minimum voltage and 110% of maximum voltage for equipment with dual nameplate voltage.

The air and liquid flow rates shall be as established in Section 6 for the air entering the indoor side or the liquid air temperature entering the heat exchanger. Equipment with dual-rated frequencies shall be tested at each frequency.

Table 16. Maximum Heating Test Conditions for VRF Water-source Heat Pumps			
—	Water-loop Heat Pumps	Ground-water Heat Pumps	Ground-loop Heat Pumps
Air entering indoor side			
— dry bulb, °F	68.0	68.0	68.0
— maximum wet bulb, °F	59.0	59.0	59.0
Air surrounding Outdoor Unit			
— dry bulb, °F	68.0	68.0	68.0
Liquid entering heat exchanger, °F	86.0	77.0	77.0
Frequency, Hz	Rated	Rated	Rated
Voltage, V	1) 90% and 110% of rated voltage for equipment with a single nameplate rating. 2) 90% of minimum voltage and 110% of maximum voltage for equipment with dual nameplate voltage.	1) 90% and 110% of rated voltage for equipment with a single nameplate rating. 2) 90% of minimum voltage and 110% of maximum voltage for equipment with dual nameplate voltage.	1) 90% and 110% of rated voltage for equipment with a single nameplate rating. 2) 90% of minimum voltage and 110% of maximum voltage for equipment with dual nameplate voltage.

The air and liquid flow rates shall be as established in Section 6 for the air entering the indoor side or the liquid air temperature entering the heat exchanger. Equipment with dual-rated frequencies shall be tested at each frequency.

8.1.3.2.3 Test Requirements. VRF Water-source Heat Pumps shall meet the following requirements when operating at the conditions specified in Table 15 and Table 16.

8.1.3.2.3.1 During the entire test, the equipment shall operate without any indication of damage.

8.1.3.2.3.2 During the test period specified in Section 8.1.3.2.2.1, the equipment shall operate continuously without tripping any motor overload or other protective devices.

8.1.3.2.3.3 During the test period specified in Section 8.1.3.2.2.3, the motor overload protective device can trip only during the first five minutes of operation after the shutdown period of three minutes. During the remainder of the test period, the motor overload protective device shall not trip. For those models designed so that resumption of operation does not occur within the first five minutes after the initial trip, the equipment shall not remain out of operation for longer than thirty minutes. The equipment shall then operate continuously for the remainder of the test period.

8.1.3.3 Minimum Operating Conditions Test. VRF Water-source Heat Pumps shall be tested at the minimum operating test conditions for cooling and heating at the test conditions established for the specific applications specified in Table 17. VRF Water-source Heat Pumps intended for use in two or more applications shall be tested at the strictest set of conditions specified in Table 17.

8.1.3.3.1 Test Procedures. For the minimum operating cooling test, the VRF Water-source Heat Pump shall be operated continuously for a period of at least thirty minutes after the specified temperature conditions have been established. For the minimum operating heating test, the VRF Water-source Heat Pump shall soak for ten minutes with liquid at the specified temperature circulating through the coil. The equipment shall then be started and operated continuously for thirty minutes.

8.1.3.3.2 Test Requirements. Protective devices shall not trip during these tests and damage shall not occur to the equipment.

Table 17. Minimum Cooling Test Conditions for VRF Water-source Heat Pumps			
—	Water-loop Heat Pumps	Ground-water Heat Pumps	Ground-loop Heat Pumps
Air entering indoor side			
— dry bulb, °F	69.8	69.8	69.8
— maximum wet bulb, °F	59.0	59.0	59.0
Air surrounding unit			
— dry bulb, °F	69.8	69.8	69.8
Liquid entering heat exchanger, °F	68.0	50.0	50.0
Frequency, Hz	Rated	Rated	Rated
Voltage, V	Rated	Rated	Rated

The air and liquid flow rates shall be as established in Section 6 for the air entering the indoor side or the liquid air temperature entering the heat exchanger. Equipment with dual-rated frequencies shall be tested at each frequency.

8.1.3.4 *Enclosure Sweat and Condensate Disposal Test.*

8.1.3.4.1 *Test Conditions.* The enclosure sweat and condensate disposal test shall be conducted in the cooling mode at the test conditions established for the applications specified in Table 8.

All System Controls, fans, dampers, and grilles shall be set to produce the maximum tendency to sweat, provided such settings are not contrary to the MII. VRF Water-source Heat Pumps intended for two or more applications shall be tested at the strictest set of conditions.

8.1.3.4.2 *Test Procedures.* After establishment of the specified temperature conditions, the VRF Water-source Heat Pump shall be operated continuously for a period of four hours.

8.1.3.4.3 *Test Requirements.* Condensed water shall not drip, run off, or blow off the equipment’s casing during the test.

8.1.4 *Tolerances.* The conditions for the tests outlined in Section 8 are average values subject to tolerances of ±1.0°F for air wet-bulb and dry-bulb temperatures, ±0.5°F for water temperatures, and ±1.0% of the readings for specified voltage.

Section 9. Marking and Nameplate Data

9.1 *Marking and Nameplate Data.* As a minimum, the nameplate shall display the manufacturer’s name, model designation, and electrical characteristics.

Nameplate voltages for 60 Hz systems shall include one or more of the equipment nameplate voltage ratings shown in Table 1 and Table 2 of AHRI 110. Nameplate voltages for 50 Hz systems shall include one or more of the utilization voltages shown in Table 1 of IEC 60038.

9.2 *Nominal Capacity.* The Nominal Capacity for Indoor and Outdoor Units shall be printed on the nameplate or listed in the manufacturer’s product literature, or both.

Section 10. Conformance Conditions

10.1 *Conformance.* While conformance with this standard is voluntary, conformance shall not be claimed or implied for products or equipment within the standard’s *Purpose* (Section 1) and *Scope* (Section 2) unless such product claims meet all of the requirements of the standard and all of the testing and rating requirements are measured and recorded in complete compliance with the standard. Any product that has not met all the requirements of the standard shall not reference, state, or acknowledge the standard in any written, oral, or electronic communication.

Section 11. Calculations

11.1 Individual Test Calculations. For individual test calculations, refer to ASHRAE 37.

11.2 IEER Calculations.

11.2.1 General IEER Equations. For units covered by this standard, the IEER shall be calculated using test derived data and Equation 9.

$$IEER = (0.020 \cdot EER_{A,Full}) + (0.617 \cdot EER_B) + (0.238 \cdot EER_C) + (0.125 \cdot EER_D) \quad 9$$

Note: A description of the following symbols are found in Section 12.2: $EER_{A, Full}$, EER_B , EER_C , and EER_D .

11.2.2 Rating Adjustments. The IEER shall be determined at the four ratings loads and condenser conditions as defined in Table 8 and Table 9. Rating adjustments shall be used to account for scenarios where the unit is unable to meet load fraction tolerances or when the SHR limit is exceeded. In these scenarios, Section 11.2.3 shall be followed to determine the rating at the required load, using the approaches described in Section 11.2.2.1 and Section 11.2.2.2.

11.2.2.1 Degradation. If the unit cannot be unloaded to within 3% of the 75%, 50%, or 25% loads and methods for Critical Parameter adjustment described in Section 6.3.3 have been exhausted, then the unit shall be run at the minimum step of unloading and minimum rated indoor airflow at the condenser conditions defined for each of the rating Percent Load IEER points listed in Table 8 and then the part-load EER shall be adjusted for cyclic performance using Equation 10 and solving C_D and LF using Equation 11 and Equation 12.

$$EER = \frac{LF \cdot q_{PL}}{LF[C_D(P_C + P_{CD})] + P_{IF} \cdot P_{CT}} \quad 10$$

Where:

$$C_D = (-0.13 \cdot LF) + 1.13 \quad 11$$

$$LF = \frac{\left(\frac{P_L}{100}\right) \cdot q_{Full}}{q_{PL}} \quad 12$$

11.2.2.2 Sensible Heat Ratio Limits. If the unit cannot meet the Sensible Heat Ratio (SHR) limits specified in Section 6.3.3.2 and methods for Critical Parameter adjustment described in Section 6.3.3 have been exhausted, then the Sensible Cooling Capacity in the EER calculation for the specific load test point shall be reduced such that the SHR limit is met for the remaining Sensible Cooling Capacity and Latent Cooling Capacity. The Sensible Cooling Capacity shall be adjusted using Equation 13. The Standard Rating Cooling Capacity shall not be adjusted. Then, the EER shall be calculated using Equation 14.

$$q_{Sens,Adj} = q_{Latent} * \frac{SHR_{Req}}{1 - SHR_{Req}} \quad 13$$

$$EER_{Adj} = \frac{q_{Sens,Adj} + q_{latent}}{\dot{E}_{tot}} \quad 14$$

11.2.3 Procedure for Calculating IEER. The IEER shall be calculated using data, Equation 9, and the following procedures. For test purposes, test units shall be provided with manual means to adjust the unit refrigeration capacity in steps not greater than 5% of the Standard Rated Cooling Capacity by adjusting the variable capacity compressor(s) capacity or the stages of refrigeration capacity, or both. The EER of individual tests shall be rounded to at least three significant figures (0.001) prior to the calculation of IEER.

11.2.3.1 These sequential steps shall be followed.

11.2.3.1.1 For part-load rating tests, the unit shall be configured in accordance with the MII, including setting of stages of refrigeration and variable capacity compressor loading percent for each of the part-load rating points. The stages of refrigeration and variable capacity compressor loading percent shall result in a capacity closest to the part-load rating points of 75%, 50%, or 25%.

11.2.3.1.2 The condenser air or water entering temperature shall be adjusted in accordance with the requirements of Table 8 or Table 9 and be within tolerance as defined in Section 6.6.

11.2.3.1.3 The indoor airflow and ESP shall be adjusted in accordance with Section 6.

11.2.3.1.4 *Bracketing the Target Load Fraction.* If the measured part-load rating capacity ratio is within three percentage points, based on the full load measured test Cooling Capacity, above or below the target part-load capacity point, the EER at each load point shall be used to determine IEER without adjustment for cyclic degradation. See Table 18.

Table 18. Tolerance on Part-load Percent		
Required Part-load (%)	Minimum Allowable Measured Part-load (%)	Maximum Allowable Measured Part-load (%)
75	72	78
50	47	53
25	22	28

11.2.3.1.5 *Exceeding the Target Load Fraction at Minimum Capacity.* If the unit cannot be unloaded to within 3% of the 75%, 50%, or 25% load points at the minimum stage of unloading after any lab adjustments of overridden Critical Parameters as described in Section 6.3.3, then the rating shall be determined at the minimum stage of unloading and part-load rating condenser air or water inlet temperature defined in either Table 8 or Table 10 for VRF Water-source Heat Pumps within the tolerances specified in Section 6.6.

The actual Percent Load is greater than the required Percent Load and is adjusted for cyclic performance using Equation 10 through Equation 12 as described in Section 11.2.2.1. Part-load Rated Indoor Airflow, if different than full load airflow, shall be used in accordance with Section 6.4.

Note: Appendix G provides example calculations.

Section 12. Symbols, Subscripts, and Superscripts

12.1 Symbols

- C_D Degradation Coefficient to account for cycling of the compressor for capacity less than the minimum step of capacity
- D_c Coil depth (uncased), in
- \dot{E}_{tot} Total Power Input
- $EER_{A, Full}$ EER at 100% Capacity at AHRI Standard Rating Conditions (see Table 8 or Table 10)
- EER_B EER at 75% Capacity and reduced condenser air or water inlet temperature (see Table 8 or Table 10)
- EER_C EER at 50% Capacity and reduced condenser air or water inlet temperature (see Table 8 or Table 10)
- EER_D EER at 25% Capacity and reduced condenser air or water inlet temperature (see Table 8 or Table 10)
- $IEER$ Integrated Energy Efficiency Ratio
- ESP_{adj} Adjusted ESP requirement at heating airflow or part-load cooling airflow, in H₂O
- ESP_{CFL} ESP requirement at full-load cooling airflow specified in Table 6, in H₂O
- f_{pa} Pump power adjustment
- L_c Coil length (uncased), in
- LCL Lower 90% confidence limit
- LF Fractional ON time for last stage at the load point under test
- n Number of systems tested
- NCV Normalized Coil Volume
- P_{adj} Total power consumption, W
- P_C Compressor power at the lowest machine unloading point operating at the part-load rating condition under test, W
- P_{CD} Condenser Section power, if applicable at the part-load rating condition under test, W. For Air-source Heat Pumps this is the power of the fan(s) and compressor(s)

P_{CT}	Control circuit power and any auxiliary loads, W
P_{IF}	Indoor Fan power, W
P_L	Percent Load
Δp_{int}	Internal static pressure difference, ft H ₂ O
Δp_{ext}	External static pressure difference, ft H ₂ O
q	Nominal fluid flow rate, gpm
q_{nom}	Nominal Indoor Unit Cooling Capacity, Btu/h
\dot{q}_{thir1}	Total capacity heating indoor room 1, Btu/h
\dot{q}_{tcir1}	Total capacity cooling indoor room 1, Btu/h
\dot{q}_{tcir2}	Total capacity cooling indoor room 2, Btu/h
q_{Full}	Full load net capacity, Btu/h
q_{PL}	Part-load Net Capacity, Btu/h
q_{Latent}	Latent Net Capacity, Btu/h
q_{sens}	Sensible Net Capacity, Btu/h
$q_{sens,Adj}$	Sensible Net Capacity following adjustments required to meet SHR limit, Btu/h
Q_{dif}	Measured part-load cooling airflow or manufacturer-specified heating airflow, scfm
Q_{CFL}	Measured full-load cooling airflow, scfm
R_2	Rate of indoor dry bulb temperature decrease during R2 period of the CVP, °F/hr
s	Standard deviation
$SCHE$	Simultaneous Heating and Cooling Efficiency
SHR	Sensible Heat Ratio
SHR_{Req}	Sensible Heat Ratio required at 100% load and 75% load test points
t_{start}	Elapsed time since beginning of CVP, indicated by t_{start}
$t_{.95}$	t statistic for a 95% one-tailed confidence interval with sample size n (see Appendix A of Subpart B of 10 CFR §429)
t_{off}	Time when the first indoor unit switches to thermally inactive during the CVP
t_{start}	Starting time of the CVP, once all CVP start criteria have been met
t_{82}	Time when the indoor room dry bulb temperature first reaches 82°F, indicating the start of the R2 period
T_{start}	Starting temperature for the CVP, °F
$T_{Measured,t}$	Indoor room dry bulb temperature at time t during the R2 period of the CVP, measured as the average temperature reading from the room conditioning system resistance temperature detectors, °F
$T_{Target,t}$	Target indoor room dry bulb temperature at time t during the R2 period of the CVP, °F
W_c	Coil width (uncased), in
x_i	Test result value for test sample i
\bar{x}	Test sample mean

12.2 Greek Symbols

ϕ_{pa}	Pump power adjustment, W
η	Conversion Factor ,1.59 gpm•ft H ₂ O/W by convention

12.3 Subscripts and Superscripts

adj	Adjustment
$Full$	Operation/compressor speed at full load test
i	Indoor
max	Maximum
min	Minimum
Var	Variance
x	Variable for an individual test, measurement, or compressor set point (for example, x can be A_{Full} , B_{Low} , $H0_{Low}$)

Section 13. Minimum Data Requirements for Published Ratings

13.1 *Minimum Data Requirements for Published Ratings.* As a minimum, Published Ratings shall consist of the following information to meet the DOE minimum efficiency standard:

13.1.1 *For VRF Systems (air conditioners):*

- Standard Rating Cooling Capacity, Btu/h;
- Energy Efficiency Ratio ($EER_{A, Full}$), (Btu/h)/W; and
- Integrated Energy Efficiency Ratio (IEER), (Btu/h)/W

13.1.2 *For VRF Systems (heat pumps):*

- Standard Rating Cooling Capacity, Btu/h;
- Energy Efficiency Ratio ($EER_{A, Full}$), (Btu/h)/W;
- Integrated Energy Efficiency Ratio (IEER), (Btu/h)/W;
- High Temperature Standard Rating Heating Capacity, Btu/h;
- Coefficient of Performance at High Temperature (COP_H) at 47°F;
- Low Temperature Standard Rating Heating Capacity, Btu/h; and
- Coefficient of Performance at Low Temperature (COP_L) at 17°F

13.1.3 *For VRF Heat Recovery Systems:*

- Applicable Ratings from Section 13.1.1 and Section 13.1.2; and
- Simultaneous Cooling and Heating Efficiency (SCHE) (50% heating/50% cooling), (Btu/h)/W

13.1.4 *For VRF Systems (water-source):*

- Standard Rating Cooling Capacity, Btu/h;
- Energy Efficiency Ratio ($EER_{A, Full}$), (Btu/h)/W;
- Integrated Energy Efficiency Ratio (IEER), (Btu/h)/W;
- Standard Rating Heating Capacity, Btu/h;
- Coefficient of Performance at High Temperature (COP_H); and
- Simultaneous Cooling and Heating Efficiency (SCHE) (50% heating/50% cooling)/ (Heat Recovery models only), (Btu/h)/W

13.2 *Latent Cooling Capacity Designation.* The moisture removal designation shall be published in the manufacturer’s specifications and literature. The value shall be expressed consistently in either gross or net in one or more of the following forms:

- Sensible Cooling Capacity/Total Cooling Capacity ratio (sensible heat ratio) and Total Cooling Capacity, Btu/h;
- Latent Cooling Capacity and Total Cooling Capacity, Btu/h; and
- Sensible Cooling Capacity and Total Cooling Capacity, Btu/h

13.3 *Rating Claims.* All claims to Standard Ratings within the scope of this standard shall include the statement “Rated in accordance with AHRI Standard 1230”. All claims to ratings outside the scope of this standard shall include the statement: “Outside the scope of AHRI Standard 1230”. Application Ratings within the scope of the standard shall include a statement of the conditions under which the ratings apply.

Section 14. Verification Testing Acceptance Criteria

14.1 To comply with this standard, verification tests shall meet the performance metrics with an uncertainty allowance not greater than shown in Table 19.

Table 19. Uncertainty Allowances		
Performance Metric	Uncertainty Allowance (%)	Acceptance Criteria ¹ (%)
Standard Rating Cooling Capacity	4	≥ 96
EER	5	≥ 95
IEER ²	10	≥ 90
SCHE ³	10	≥ 90
Standard Rating Heating Capacity	4	≥ 96
COP ²	5	≥ 95
Notes:		
1. $\geq (1 - \text{uncertainty allowance})$		
2. Includes the high temperature and low temperature conditions, and the temperature condition for VRF Water-source Heat Pump systems		
3. Applies to heat recovery systems only		

14.2 Verification Testing Uncertainty. When verifying the ratings by testing a sample unit, uncertainties can be reviewed. Verification tests shall be conducted in a laboratory that meets the requirements referenced in this standard and ASHRAE 37 and shall demonstrate performance with an allowance for uncertainty. Section 14.2.1 through Section 14.2.6 describe the verification testing uncertainty for the products covered by this standard.

14.2.1 Uncertainty of Measurement. When testing a unit, there are variations that result from instrumentation and measurements of temperatures, pressure, and flow rates.

14.2.2 Uncertainty of Test Rooms. A unit tested in multiple rooms cannot yield the same performance due to setup variations and product handling.

14.2.3 Variation due to Manufacturing. During the manufacturing of units, there are variations due to manufacturing production tolerances that impact the performance of a unit.

14.2.4 Uncertainty of Performance Simulation Tools. Due to the large complexity of options, use of performance prediction tools such as an Alternative Efficiency Determination Method (AEDM) can have uncertainties.

14.2.5 Variability of System under Test. The requirement to lock the compressor speed to achieve different capacity targets during the test can lead to system instability, causing unrepeatability. In addition, as the number of components assembled increases, the variability in the test results increases.

14.2.6 Variability due to Environmental Conditions. Changes to ambient conditions such as inlet temperature conditions and barometric pressure can alter the measured performance of the unit.

APPENDIX A. REFERENCES – NORMATIVE

A1 Listed here are all standards, handbooks, and other publications essential to the formation and implementation of the standard. All references in this appendix are considered as part of this standard.

A1.1 AHRI Standard 110-2016, *Air-Conditioning and Refrigerating Equipment Nameplate Voltages*, 2016, Air-Conditioning, Heating, and, Refrigeration Institute, 2311 Wilson Blvd, Suite 400, Arlington, VA 22201, USA.

A1.2 AHRI Standard 210/240-2023 (2020), *Unitary Air-Conditioning and Air-Source Heat Pump Equipment*, 2023, Air-Conditioning, Heating, and, Refrigeration Institute, 2311 Wilson Blvd, Suite 400, Arlington, VA 22201, USA.

A1.3 AHRI Standard 340/360-2022 (I-P), *Commercial and Industrial Unitary Air-Conditioning and Heat Pump Equipment*, 2022, Air-Conditioning, Heating, and Refrigeration Institute, 2311 Wilson Blvd, Suite 400, Arlington, VA 22201, USA.

A1.4 AHRI Standard 470-2006 (SI/I-P), *Performance Rating of Desuperheater/Water Heaters*, 2006, Air-Conditioning, Heating, and Refrigeration Institute, 2311 Wilson Blvd, Suite 400, Arlington, VA 22201, USA.

A1.5 ANSI/AHRI Standard 365-2009 (I-P), *Commercial and Industrial Unitary, Air Conditioning Condensing Units*, 2009, Air-Conditioning, Heating, and Refrigeration Institute, 2311 Wilson Blvd, Suite 400, Arlington, VA 22201, USA.

A1.6 ANSI/AMCA Standard 210-2016/ANSI/ASHRAE Standard 51-2016, *Laboratory Methods of Testing Fans for Certified Aerodynamic Performance Rating*, 2016, Air Movement and Control Association International, 30 W. University Dr, Arlington Heights, IL 60004-1893, USA.

A1.7 ANSI/AHRI/ASHRAE ISO 13256-1:1998 (RA 2012), *Water-source Heat pumps - Testing and rating for Performance - Part 1: Water-to-air and Brine-to-air Heat Pumps*, 2012, AHSRAE, 180 Technology Parkway NW, Peachtree Corners, GA 30092, USA.

A1.8 ANSI/ASHRAE Standard 30-2019, *Methods of Testing Liquid Chillers*, 2019, AHSRAE, 180 Technology Parkway NW, Peachtree Corners, GA 30092, USA.

A1.9 ANSI/ASHRAE Standard 37-2009 (RA 2019), *Methods of Testing for Rating Unitary Air-Conditioning and Heat Pump Equipment*, 2009, AHSRAE, 180 Technology Parkway NW, Peachtree Corners, GA 30092, USA.

A1.10 ANSI/ASHRAE Standard 41.1-2020, *Standard Methods for Temperature Measurement*, 2020, AHSRAE, 180 Technology Parkway NW, Peachtree Corners, GA 30092, USA.

A1.11 ASHRAE Terminology. Accessed August 23, 2023. <https://www.ashrae.org/technical-resources/free-resources/ashrae-terminology>

A1.12 IEC 60038:2009+Amd1:2021, *IEC Standard Voltages*, 2021, International Electrotechnical Commission, 3, rue de Varembe, P.O. Box 131, 1211 Geneva 20, Switzerland.

A1.13 Title 10, *Code of Federal Regulations (CFR)*, §429 and §430, US National Archives and Records Administration, 8601 Adelphi Road, College Park, MD 20740-6001, USA or www.ecfr.gov.

APPENDIX B. REFERENCES – INFORMATIVE

B1 Listed here are standards, handbooks, and other publications which may provide useful information and background but are not considered essential. References in this appendix are not considered part of the standard.

B1.1 ISO 3966:2020, *Measurement of fluid flow in closed conduits — Velocity area method using Pitot static tubes*, 2020, International Organization for Standardization, Chemin de Blandonnet 8, CP 401, 1214 Vernier, Geneva, Switzerland.

B1.2 ISO 5151:2017, *Non-ducted air conditioners and heat pumps — Testing and rating for performance*, 2017, International Organization for Standardization, Chemin de Blandonnet 8, CP 401, 1214 Vernier, Geneva, Switzerland.

B1.3 ISO 5167-1:2020, *Measurement of fluid flow by means of pressure differential devices inserted in circular cross-section conduits running full — Part 1: General principles and requirements*, 2020, International Organization for Standardization, Chemin de Blandonnet 8, CP 401, 1214 Vernier, Geneva, Switzerland.

B1.4 JIS B 8616:2015, *Package air conditioners*, 2016, JSA Group, 3-13-12 Mita, Minato-Ku, Tokyo 108-0073 Japan.

APPENDIX C. CONTROLS VERIFICATION PROCEDURE (CVP) – NORMATIVE

C1 Purpose. This procedure verifies behavior for System Controls and establishes system operation boundaries for settings of Critical Parameters that are manually overridden during Steady-state Tests under cooling conditions.

Note: This procedure is based upon the minimum compressor speed verification procedure specified in JIS B 8616, with modifications and steps added.

C2 Scope. This procedure shall be applied to system cooling operations and for all VRF Systems covered under the scope of this standard.

C3 Test Set-Up Requirements. All test set-up requirements shall be in accordance with Section 5, except for Control Settings.

C3.1 Control Settings. Control settings shall be identical to those used during the Steady-state Tests at cooling conditions, except that the Control Settings for Critical Parameters that are overridden during the Steady-state Test shall not be overridden for the CVP. The same settings are to be used and to remain unchanged for the full-load and all part-load test points except for Indoor Unit(s) that are Thermally Inactive, when the Indoor Unit Control Settings such as using remote or wireless thermostat shall be set to “OFF.”

C3.2 Thermally Active Indoor Units. For all load test points, begin the CVP with the Indoor Units specified in the STI as Thermally Active. Refer to Section 5.10 for further instruction. The operation of Thermally Active Indoor Units shall be controlled by the system under test for the remainder of the CVP, except for the preliminary set point adjustment procedures in Section C3.3.

C3.3 Set Point Adjustment. Prior to starting the CVP, follow the provisions in Section 5.1.5 to adjust for Set Point Bias and Set Point Offset.

C3.4 Set Point Bias Validation. If the manufacturer certifies thermostat set points other than 80°F in the STI to account for Set Point Bias, the Set Point Bias shall be validated using a CVP at any load point. The Set Point Bias is validated if all Indoor Units that are designated as Thermally Active at the beginning of the CVP become Thermally Inactive by the time the return air decreases to 77°F.

C3.5 Oil Recovery During CVP. All CVP runs shall be conducted with active Oil Recovery Mode.

C4 Operating Conditions. The Indoor dry-bulb temperature and ramp-down rates vary during CVP, as specified in this section. All test operating and condition tolerances shall be in accordance with Section 6, unless otherwise specified in this section.

C4.1 Indoor Dry Bulb Starting Temperature. Indoor dry-bulb temperature is measured as the average temperature reading from the room conditioning system resistance temperature detectors. Instantaneous measurements of indoor dry bulb temperature are denoted as ($T_{\text{Measured},t}$). At each load point, the starting temperature for the CVP (T_{start}) can be specified in the STI and shall be not less than 82°F and not greater than 86°F. If a starting temperature is not specified in the STI, a default starting temperature of 86°F shall be used.

C4.2 CVP Start Time (t_{start}). With the VRF System thermally off, compressors not running, control the room conditioning equipment until test room conditions are in accordance with Section 6, except that the indoor dry-bulb temperature shall be within +0.5/-0°F of the starting temperature described in Section C4.1. Once these test room conditions are attained, control the VRF System so that the system is thermally on by adjusting the Indoor Unit thermostat set points until the values match the thermostat set points determined in Section C3.3. The stabilization period discussed in Section C4.3 is initiated once the compressor(s) begin operating.

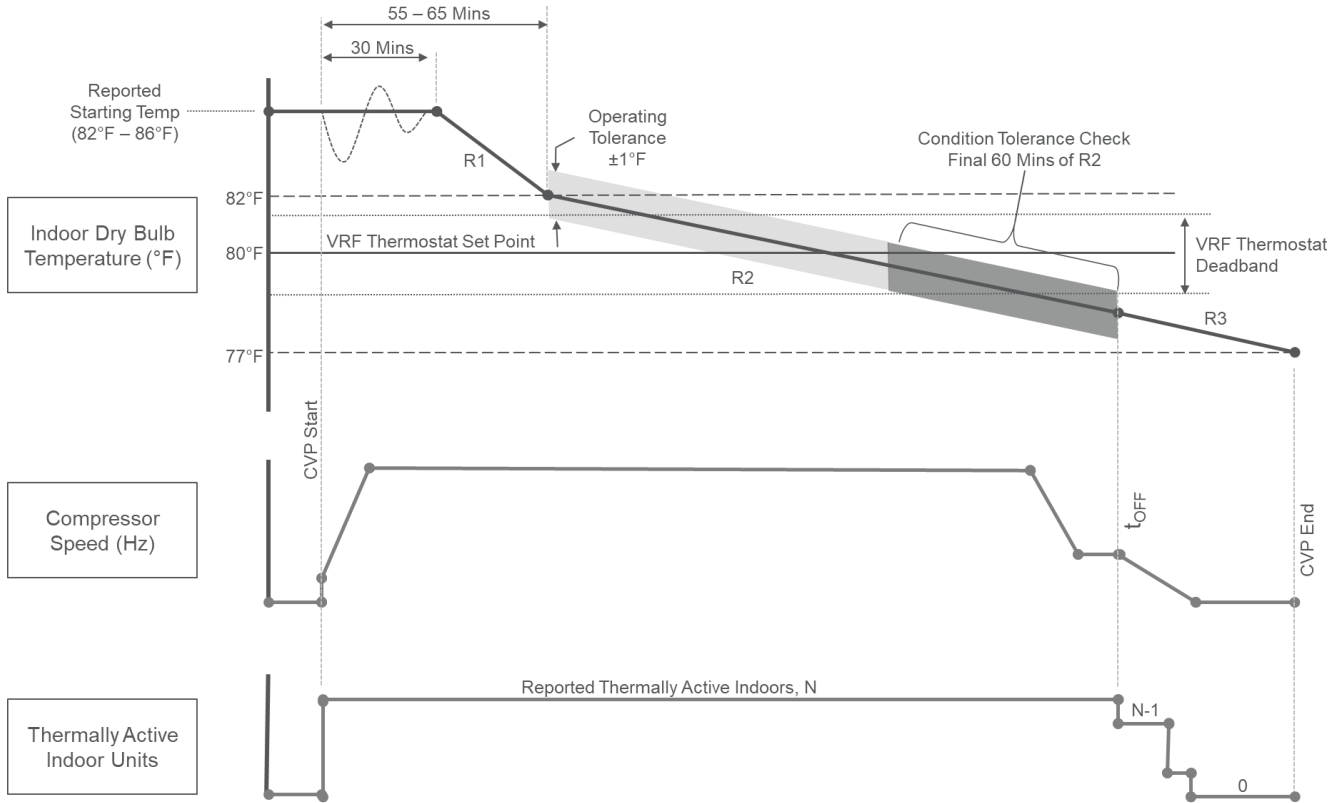

Figure C1. Controls Verification Procedure (CVP) Schematic

C4.3 Stabilization Period. When the VRF System turns thermally on, fluctuations in indoor room and outdoor room temperatures can occur. The test room conditions shall be stabilized by holding the thermostat set points constant for the VRF System for at least thirty minutes. Section 6 condition and operating tolerances do not apply during the stabilization period. Maintain indoor room temperature above 82°F to prevent nuisance trips of Indoor Units. If any Indoor Unit(s) become Thermally Inactive during the stabilization period, restart the stabilization period after bringing the Indoor Unit(s) back to Thermally Active.

C4.4 Indoor Dry Bulb Temperature Ramp Rate. The indoor dry bulb temperature ramp rate is defined as the change in indoor dry bulb temperature divided by the change in time. The CVP consists of three periods of indoor dry bulb ramping: R1, R2, and R3.

C4.4.1 R1 Period. Immediately after the stabilization period described in Section C4.3, begin decreasing the indoor room dry bulb temperature at a constant rate by incrementally reducing the temperature set point for the indoor room conditioning system. The R1 ramp rate shall be selected such that the indoor room reaches 82°F between twenty-five minutes and thirty-five minutes after the stabilization period.

C4.4.2 R2 Period. From the time that the measured indoor room dry bulb temperature first crosses from greater than 82°F to less than 82°F (t_{82}), begin decreasing the indoor dry bulb temperature at rate R2, specified within STI between 0.5°F/hr and 4.0°F/hr, by incrementally reducing the temperature set point for the indoor room conditioning system. When multiple indoor chambers are used in the test setup, the R2 period begins when the last indoor chamber crosses from greater than 82°F to less than 82°F within 2 minutes of the first chamber, otherwise restart from the beginning. The R2 period ends at the time when any Indoor Unit that is designated Thermally Active at the start of the CVP goes Thermally Inactive (t_{off}).

C4.4.2.1 Ramp Rate Verification for R2 Period. Each minute calculate the difference (ΔT_t) between the measured indoor room temperature ($T_{Measured,t}$) and the target indoor room dry bulb temperature ($T_{Target,t}$) using Equation C1 and Equation C2. The indoor dry bulb ramp rate shall be verified during the R2 period by applying operating and condition tolerances to ΔT_t as specified in Table C1. When multiple indoor chambers are used in test setup, operating and condition tolerances in Table C1 apply to each indoor chamber separately.

$$T_{Target,t} = 82 - R_2 \times (t - t_{82}) \tag{C1}$$

$$\Delta T_t = T_{Measured,t} - T_{Target,t} \tag{C2}$$

C.4.4.2.2 Oil Recovery During R2 Period. If an oil recovery cycle is automatically initiated during the R2 period of the CVP, pause the CVP by holding the indoor room temperature set point constant for thirty minutes. During this thirty-minute period, operating tolerances do not apply, and the time index *t* shall be paused. Once thirty minutes have elapsed, resume the CVP by incrementally reducing the indoor room dry bulb temperature set point to achieve the specified ramp rate R2 and resume the time index *t*. If the oil recovery cycle occurs within the final sixty minutes of the CVP where condition tolerances are applied, then the CVP run shall be restarted from the beginning. If the measured compressor speed first falls below the STI-reported compressor speed during the thirty-minute oil recovery pause, repeat the test from the beginning.

Table C1. Indoor Dry Bulb Temperature Tolerances – R2 Period

Tolerance Type	Applies to	Value	Standard Rating Cooling Capacity
Operating	Entire R2 Period except for first thirty minutes following oil recovery	$-1.0^{\circ}\text{F} \leq \Delta T_t \leq 1.0^{\circ}\text{F}$	Less than 120,000 Btu/h
		$-1.0^{\circ}\text{F} \leq \Delta T_t \leq 1.5^{\circ}\text{F}$	120,000 to 360,000 Btu/h
		$-1.0^{\circ}\text{F} \leq \Delta T_t \leq 2.0^{\circ}\text{F}$	Greater than 360,000 Btu/h
Condition	Last sixty minutes of R2 Period	$\frac{\sum_1^N \Delta T_t }{N} \leq 0.50^{\circ}\text{F}$ N = # of measurements in final 60 minutes of R2 period	N/A

C4.4.2.3 Calculating Critical Parameter Variation During R2 Period. At each data collection interval during the R2 period, calculate the absolute Parameter Percent Difference (PPD_{*i,t*}) between each measured Critical Parameter value and the STI-reported value for that parameter using Equation C3. At each load point, for any Critical Parameter whose value is not specified in the STI, such as those not designated as being manually overridden during the corresponding steady-state test, the Parameter Percent Difference shall be calculated as zero for the duration of the CVP.

$$PPD_{i,t} = \left| \frac{CP_{i,t} - CP_{i,STI}}{CP_{Max}} \right| \times 100 \tag{C3}$$

Where:

i identifies the Critical Parameter – either Compressors Speed(s), Outdoor Fan Speed(s), or Outdoor Variable Valve Position(s).

*CP_{*i,t*}* = The average value across all instances of Critical Parameter *i* as measured at time *t*. If multiple instances of a single parameter are present, for example multiple compressors, calculate the average value for all instances of that parameter when determining *CP_{*i,t*}*.

*CP_{*i,STI*}* = The average value across all instances of Critical Parameter *i* as reported in the STI for the corresponding load point. If multiple components corresponding to a single parameter are present, calculate the average position across all components corresponding to that parameter at each measurement interval when determining *CP_{*i,STI*}*.

CP_{Max} = The maximum value for Critical Parameter *i*, as measured during a CVP conducted at 100% load conditions. If multiple instances of a single parameter are present, first calculate the average value across all instances before determining the maximum [average] value observed during the 100% CVP. If the CVP is not conducted at the 100% load, the STI-reported value for the 100% load is used for this calculation.

C4.4.3 R3 Period. Once the first Indoor Unit goes Thermally Inactive, the indoor room dry bulb temperature shall continue decreasing at rate R2 until the indoor room reaches 77°F. Set Point Bias, if present, can be

validated using the provisions in C3.4. Operating or condition tolerances on indoor dry bulb temperature do not apply during the R3 period.

C4.5 Humidity. The return air humidity ratio shall be held constant at $0.0112 \pm 0.0006 \text{ lbm}_{\text{wv}} / \text{lbm}_{\text{da}}$ at 100% and 75% load test points for air-source VRF and at $0.0105 \pm 0.0006 \text{ lbm}_{\text{wv}} / \text{lbm}_{\text{da}}$ at 100% and 75% load test points for water-source VRF. The same value and tolerance for humidity shall apply for the 50% and 25% load test points, unless the STI indicates that SHR for these load test points is 100%. In this case, the humidity level shall be low enough to prevent latent load. For indoor units other than those that are controlled via humidistat, operating, and condition tolerances on humidity do not apply during the R3 period.

C5 Measured Parameters During CVP. Table C2 outlines the measurement requirements for the CVP parameters that shall be continuously measured as defined by the minimum data collection intervals.

Parameter	Measurement Apparatus	Minimum Data Collection Interval (samples/hour)
Thermostat set points, °F	Indoor Unit thermostat, Service Tool	60
Compressor speed ¹ , Hz / rps	Service Tool	60
Number of running compressors and identification of the compressors running ¹	Service Tool	60
Outdoor fan speed and number of outdoor fans running ¹ , rpm	Service Tool	60
Identification of active indoor units	Refer to Section 3.2.44	60
All Outdoor Variable Valve positions ¹ , pulses	Service Tool	60
All Outdoor Two-position Valve positions	Service Tool	60
Note: 1. These parameters are both CVP parameters and Critical Parameters		

C5.1 Service Tool. Use the Service Tool currently available for download from the manufacturer’s certified installer website (software) or provided by the manufacturer (software) or the publicly available physical lab tool as shown in Table C2 (hardware). If a Service Tool does not have the capability to automatically record parameters simultaneously at the required time intervals listed in Section C5, then manual recordings shall be taken at the intervals prescribed in Section C5.

C6 Verification Criteria.

C6.1 Systems with Observed Critical Parameter Variation. The verification criteria for systems with overridden parameters that differ from the values reported in the STI involves the implementation of a budget system. Parameters are verified based on points accumulated from Critical Parameter variation and compared to a budget that encompasses the points from all overridden parameters.

C6.1.1 Calculating RSS Point Total. At each data collection interval during the R2 period, calculate the RSS Point Total using the calculated $PPD_{i,t}$ described in Section C4.4.2.3, the Nominal Point Values listed in Table C3, and Equation C4 and Equation C5.

$$Points_{i,t} = PPD_{i,t} \times NPV_i \tag{C4}$$

$$RSS\ Points_t = \sqrt{(Points_{Compressors,t})^2 + (Points_{Fans,t})^2 + (Points_{LEV_s,t})^2} \tag{C5}$$

Where:

NPV_i is the Nominal Point Value for Critical Parameter i (nominal Point Values are listed in Table C3)

C6.1.2 The duration of the period used for validating critical parameter values shall be the longer of the following: Three minutes, or the time period needed to obtain five sample readings while meeting the minimum data collection interval requirements of Table C2.

C6.1.3 The certified critical parameters are valid if, before t_{OFF} , at least one measurement period with a duration identified in Section C6.1.2 has an average RSS Point Total over the measurement period that is less than or equal to 70 points exists.

C6.1.4 The certified critical parameters are invalid if, before t_{OFF} , at least one measurement period with a duration identified in Section C6.1.2 has an average RSS Point Total over the measurement period that is less than or equal to seventy points does not exist.

Table C3. Critical Parameter Nominal Point Values	
Parameter	Nominal Point Value
Compressor Speed(s)	13
Outdoor Fan Speed(s)	7
Outdoor Variable Valve position(s)	1

C6.2 *Invalidated Critical Parameter Settings.* If Critical Parameter values are found to be invalid according to the results of the CVP, determine alternate critical parameter values for use in the corresponding IEER test. Determine alternate Critical Parameter values from the CVP results of the single system as follows:

C6.2.1 *Select the CVP Measurement Period*—this period shall have a duration determined in accordance with C6.1.2 and shall be the period where the RSS Point Total has a lower average value over the measurement period than over any other period in the CVP of the same duration. If multiple periods exist with the same RSS Point Total, select the measurement period closest to but before t_{OFF} .

C6.2.2 *Determine Alternate Critical Parameters*—calculate the average position for each Critical Parameter during the measurement period selected in Section C6.2.1. When initially setting critical parameters in accordance Section 5.1.2, use the alternate Critical Parameter values as control inputs instead of using the Critical Parameter values. The same initial alternate Critical Parameter values shall be used for all systems in the testing sample, though Critical Parameter adjustments as needed to achieve target capacity or sensible heat ratio (SHR) limits are made independently for each tested system.

C6.2.2.1 For each system, determine whether Critical Parameter adjustments are needed to achieve the target capacity or SHR limit for an IEER cooling test. Perform Critical Parameter adjustments independently on each system as described in Section 6.3.3, with the following deviations:

- Replace all references to “Critical Parameter values” with “alternate Critical Parameter values” as determined in Section C6.2.2.
- Determine CP_{Max} from a CVP conducted at full-load cooling conditions as the maximum value observed during the R2 period as described in Section C.4.4.2.3 of AHRI 1230.

If multiple components corresponding to a single parameter are present, determine CP_{Max} at the point during the R2 period when the average value across all components corresponding to that critical parameter is maximized.

APPENDIX D. DEVELOPMENT OF SUPPLEMENTAL TESTING INSTRUCTIONS (STI) FOR SET-UP AND TESTING - INFORMATIVE

D1 Purpose. This appendix provides guidance for manufacturers to develop the STI to detail the manufacturer’s requirements for installation of a VRF System in a testing laboratory. Manufacturers should provide STI, in accordance with this appendix, 10 CFR §429.12, 10 CFR §429.43, and 10 CFR §429.70, for testing their equipment. This provides a uniform approach to determine minimum and other Standard Rating metrics. For official STI requirements, refer to 10 CFR Part 429 and Part 431.

D2 Background. Manufacturers providing certified ratings to the US Department of Energy, as stated in 10 CFR § 429.43, Commercial heating, ventilating, air conditioning (HVAC) equipment should follow the instructions in this appendix:

“(b)(4) Pursuant to § 429.12(b)(13), a certification report must include supplemental information submitted in PDF format. The equipment-specific, supplemental information must include any additional testing and testing set up instructions (*e.g.*, charging instructions) for the basic model; identification of all special features that were included in rating the basic model; and all other information (*e.g.*, operational codes or component settings) necessary to operate the basic model under the required conditions specified by the relevant test procedure. A manufacturer may also include with a certification report other supplementary items in PDF format (*e.g.*, manuals) for DOE consideration in performing testing under subpart C of this part. The equipment-specific, supplemental information must include at least the following:

“(iii) Variable refrigerant flow multi-split air-cooled air conditioners (other than air-cooled with rated cooling capacity less than 65,000 btu/h):”

“(A) When certifying compliance with an EER standard ...”

“(B) When certifying compliance with an IEER standard (for requirements in this list pertaining to or affected by indoor units, the requirements must be certified for each tested combination as required under paragraph (a)(3)(ii)(C) of this section): The nominal cooling capacity in British thermal units per hour (Btu/h) for each indoor and outdoor unit; identification of the indoor units to be thermally active for each IEER test point; the rated indoor airflow for the full-load cooling and all part-load cooling tests (for each indoor unit) in standard cubic feet per minute (scfm); the indoor airflow control setting to be used in the full-load cooling test (for each indoor unit); system start-up or initialization procedures, including conditions and duration; compressor break-in period duration of 20 hours or less; the frequency of oil recovery cycles; operational settings for all critical parameters to be controlled at each of the four IEER cooling test conditions; all dip switch/control settings used for the full-load cooling test; identification of any system control device required for testing; a hierarchy of instructions for adjustment of critical parameters to reduce cooling capacity during IEER cooling tests (to be used if, using initial critical parameter settings, the measured cooling capacity is more than 3 percent above the target cooling capacity); any additional testing instructions if applicable; and if a variety of motors/drive kits are offered for sale as options in the basic model to account for varying installation requirements, the model number and specifications of the motor (to include efficiency, horsepower, open/closed, and number of poles) and the drive kit, including settings, associated with that specific motor that were used to determine the certified rating. Instructions for conducting a controls verification procedure (as described in Appendix C of AHRI 1230–2021, (incorporated by reference, *see* § 429.4) at each of the four IEER cooling test conditions must also be provided, including: the required thermostat setpoints to ensure control for 80 °F dry bulb temperature when accounting for setpoint bias, the starting indoor dry bulb temperature, and the indoor dry bulb temperature ramp rate (R2). Additionally, the manufacturer must provide a layout of the system set-up for testing (including a piping diagram, a power wiring diagram, a control wiring diagram, and identification of the location of the component(s) corresponding to each critical parameter to be controlled), set-up instructions for indoor units and outdoor units, and charging instructions consistent with the installation manual.”

“(viii) Variable refrigerant flow multi-split heat pumps (other than air-cooled with rated cooling capacity less than 65,000 btu/h):”

“(A) When certifying compliance with an EER standard ...”

“(B) When certifying compliance with an IEER standard (for requirements in this list pertaining to or affected by indoor units, the requirements must be certified for each tested combination as required under paragraph (a)(3)(ii)(C) of this

section): The nominal cooling capacity in British thermal units per hour (Btu/h) for each indoor and outdoor unit; the nominal heating capacity (Btu/h) for each indoor and outdoor unit; components needed for heat recovery, if applicable; identification of the indoor units to be thermally active for each IEER test point; the rated indoor airflow for the full-load cooling, full-load heating, and all part-load cooling tests (for each indoor unit) in standard cubic feet per minute (scfm); the indoor airflow control setting to be used in the full load cooling test (for each indoor unit); the airflow-control setting to be used in the full-load heating test (for each indoor unit); for water-cooled units—the rated water flow rate in gallons per minute (gpm); system start-up or initialization procedures, including conditions and duration; compressor break-in period duration of 20 hours or less; the frequency of oil-recovery cycles; operational settings for all critical parameters to be controlled at each of the four IEER cooling test conditions; operational settings for all critical parameters to be controlled for the heating test; all dip switch/control settings used for the full-load cooling and full-load heating tests; identification of any system control device required for testing; a hierarchy of instructions for adjustment of critical parameters to reduce cooling capacity during IEER cooling tests (to be used if, using initial critical parameter settings, the measured cooling capacity is more than 3 percent above the target cooling capacity); any additional testing instructions if applicable; and if a variety of motors/drive kits are offered for sale as options in the basic model to account for varying installation requirements, the model number and specifications of the motor (to include efficiency, horsepower, open/closed, and number of poles) and the drive kit, including settings, associated with that specific motor that were used to determine the certified rating. Instructions for conducting a controls verification procedure (as described in Appendix C of AHRI 1230–2021) at each of the four IEER cooling test conditions must also be provided, including the required thermostat setpoints to ensure control for 80 °F dry-bulb temperature when accounting for setpoint bias, the starting indoor dry-bulb temperature, and the indoor dry-bulb temperature ramp rate (R2). Additionally, the manufacturer must provide a layout of the system set-up for testing (including a piping diagram, a power wiring diagram, a control wiring diagram, and identification of the location of the component(s) corresponding to each critical parameter to be adjusted), set-up instructions for indoor units and outdoor units, and charging instructions consistent with the installation manual.”

D3 Supplemental Testing Instructions. Manufacturers of VRF Systems develop and submit STI for each Basic Model to verify that their VRF Systems can be correctly installed in the laboratory and tested by a DOE-designated third-party testing organization. The following include the requirements identified in 10 CFR §429.43 as a reference only, followed by additional inclusions to the STI for each Basic Model:

D3.1 10 CFR §429.43 Required STI Inclusion (provided for information in this standard).

- Nominal Cooling Capacity (Btu/h) for each indoor and outdoor unit
- Nominal heating capacity (Btu/h) for each indoor and outdoor unit
- Components needed for heat recovery, if applicable
- Identification of the indoor units to be thermally active for each IEER test point
- Rated indoor airflow for the full-load cooling, full-load heating, and all part-load cooling tests (for each indoor unit) in standard cubic feet per minute (scfm)
- Indoor airflow control setting to be used in the full load cooling test (for each indoor unit)
- Indoor airflow control setting to be used in the full-load heating test (for each indoor unit)
- For water-cooled units—the rated water flow rate in gallons per minute (gpm)
- System start-up or initialization procedures, including conditions and duration
- Compressor break-in period duration (20 hours or less)
- Frequency of oil-recovery cycles
- Operational settings for all critical parameters to be controlled at each of the four IEER cooling tests. See example Table D1
- Operational settings for all critical parameters to be controlled for the heating test
- All dip switch/control settings used for the full-load cooling and full-load heating tests
- Identification of any system control device required for testing
- A hierarchy of instructions for adjustment of critical parameters to reduce cooling capacity during IEER cooling tests (to be used if, using initial critical parameter settings, the measured cooling capacity is more than 3 percent above the target cooling capacity)
- Any additional testing instructions if applicable
- If a variety of motors/drive kits are offered for sale as options in the basic model to account for varying installation requirements, the model number, and specifications of the motor (to include efficiency, horsepower, open/closed, and number of poles) and the drive kit, including settings, associated with that specific motor that were used to determine the certified rating.
- A layout of the system set-up for testing (including a piping diagram, a power wiring diagram, a control wiring diagram, and identification of the location of the component(s) corresponding to each critical

parameter to be adjusted), set-up instructions for indoor units and outdoor units, and charging instructions consistent with the installation manual.

D3.2 CVP Data Requirements.

D3.2.1 Required thermostat setpoints to verify control for 80°F dry-bulb temperature when accounting for setpoint bias. Adjustments for set point offset are addressed separately in Section 5.1.5.2.

D3.2.2 The starting indoor dry bulb temperature (between 82°F and 86°F)

D3.2.3 The indoor dry bulb temperature ramp rate R2

Table D1. Example Template for Reporting Format for Critical Parameters						
Critical Parameters			Test Load Point			
Group	Unique ID	Measurement Units	100%	75%	50%	25%
Compressor	Comp 1	Hz				
Compressor	Comp 2	Hz				
Outdoor Fan	ODF 1	RPS				
Outdoor Fan	ODF 2	RPS				
Modulating Valve	MV 1	Pulses				
Modulating Valve	MV 2	Pulses				
Modulating Valve	MV 3	Pulses				

D4 *Examples of PDF Graphics.* Examples of wiring and piping diagrams for VRF Systems are presented in Figure D1, Figure D2, and Figure D3.

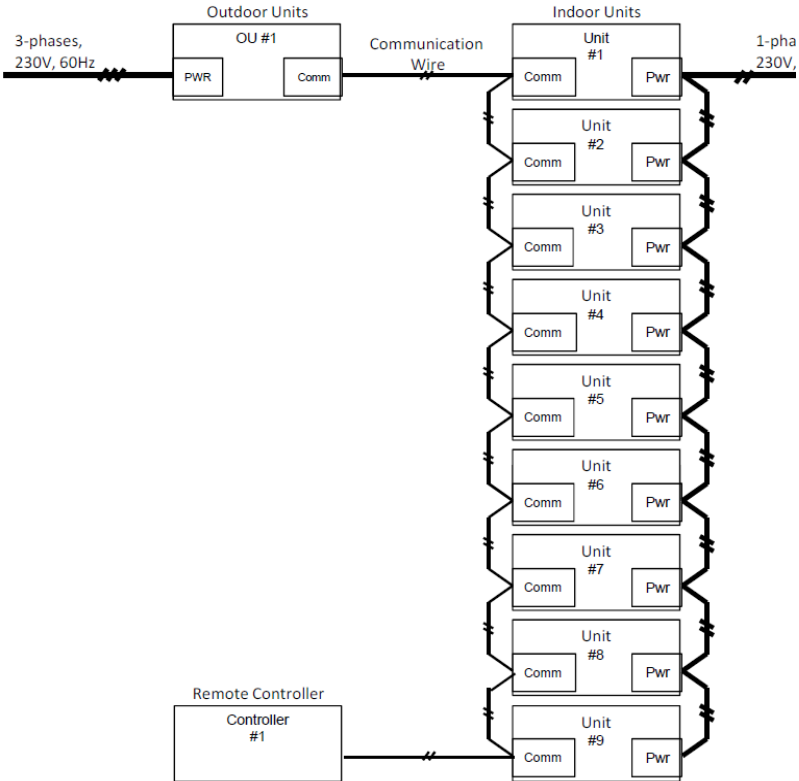

Figure D1. Example Wiring Diagram for Heat Pump

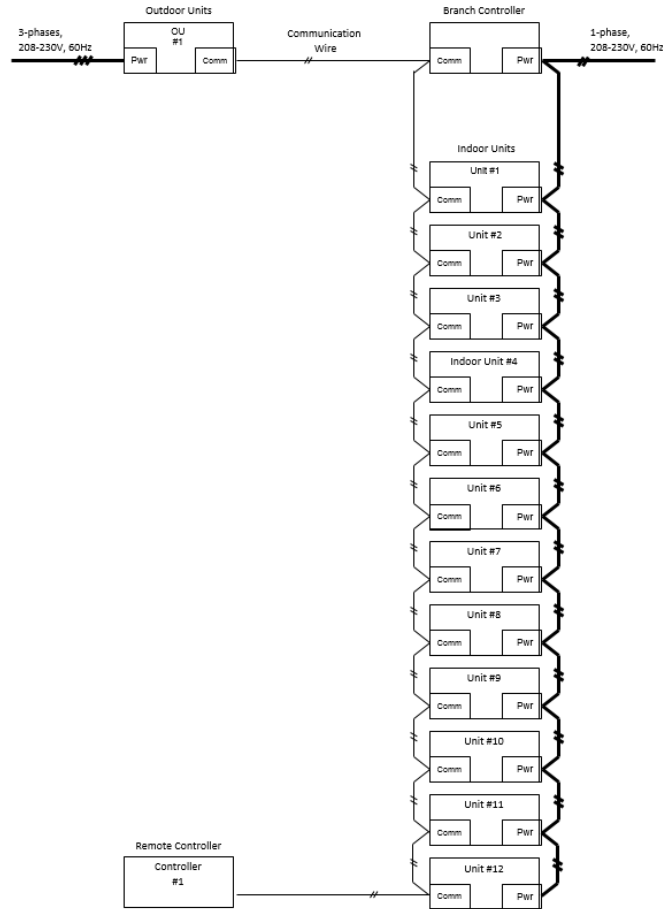

Figure D2. Example Wiring Diagram for VRF Heat Recovery System

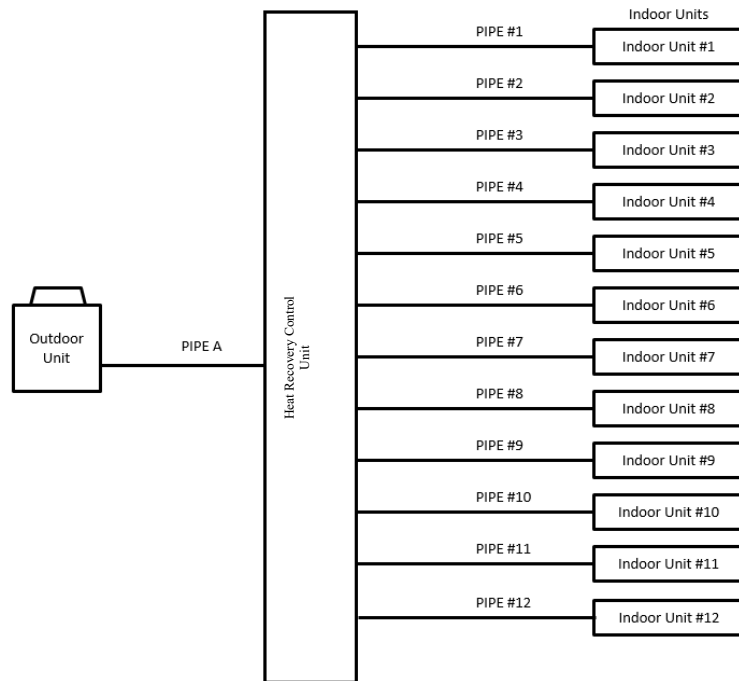

Figure D3. Example Piping Diagram for VRF Heat Recovery System

D5 Example Piping for Heat Recovery Systems. Table D2 provides example pipe lengths for Heat Recovery Systems.

Table D2. Example Piping for VRF Heat Recovery System

System Model Number	Duct/Non-ducted	Indoor Unit		PIPE A	#1	#2	#3	#4	#5	#6	#7	#8	#9	#10	#11	#12		
				(ft)	(ft)	(ft)	(ft)	(ft)	(ft)	(ft)	(ft)	(ft)	(ft)	(ft)	(ft)	(ft)	(ft)	(ft)
Outdoor model #1	Ducted	Liquid or high pressure side	Size	5/8"	1/4"	1/4"	1/4"	3/8"	3/8"	3/8"	1/4"	1/4"	3/8"	3/8"	3/8"	3/8"	3/8"	
			Length	12	13	13	13	13	13	13	13	13	13	13	13	13	13	13
		Vapor or low pressure side	Size	1/2"	1/2"	1/2"	5/8"	5/8"	5/8"	1/2"	1/2"	5/8"	5/8"	5/8"	5/8"	5/8"	5/8"	5/8"
			Length	12	13	13	13	13	13	13	13	13	13	13	13	13	13	13
	Non-ducted	Liquid or high pressure side	Size	5/8"	1/4"	3/8"	3/8"	3/8"	3/8"	3/8"	3/8"	3/8"	3/8"	—	—	—	—	—
			Length	37	13	13	13	13	13	13	13	13	13	—	—	—	—	—
		Vapor or low pressure side	Size	7/8"	1/2"	5/8"	5/8"	5/8"	5/8"	5/8"	5/8"	5/8"	5/8"	—	—	—	—	—
			Length	37	13	13	13	13	13	13	13	13	13	—	—	—	—	—
Outdoor model #2	Ducted	Liquid or high pressure side	Size	5/8"	3/8"	3/8"	3/8"	3/8"	3/8"	3/8"	3/8"	3/8"	3/8"	3/8"	3/8"	—	—	
			Length	37	13	13	13	13	13	13	13	13	13	13	13	—	—	
		Vapor or low pressure side	Size	1-1/8"	5/8"	5/8"	5/8"	5/8"	5/8"	5/8"	5/8"	5/8"	5/8"	5/8"	5/8"	5/8"	—	—
			Length	37	13	13	13	13	13	13	13	13	13	13	13	13	—	—
	Non-ducted	Liquid or high pressure side	Size	5/8"	3/8"	3/8"	3/8"	3/8"	3/8"	3/8"	3/8"	3/8"	3/8"	3/8"	3/8"	3/8"	3/8"	—
			Length	87	13	13	13	13	13	13	13	13	13	13	13	13	13	—
		Vapor or low pressure side	Size	1-1/8"	5/8"	5/8"	5/8"	5/8"	5/8"	5/8"	5/8"	5/8"	5/8"	5/8"	5/8"	5/8"	5/8"	—
			Length	87	13	13	13	13	13	13	13	13	13	13	13	13	13	—

APPENDIX E. METHOD OF TESTING VARIABLE REFRIGERANT FLOW PRODUCTS – NORMATIVE

This appendix prescribes the test procedures used for testing variable refrigerant flow equipment. Testing shall comply with ASHRAE 37 and with the modifications and additional requirements in this appendix.

Note: All figures in this appendix are example representations of test setups and are informative.

E1 The laboratory shall follow Section 5.1 of ASHRAE 37 with the following modifications made for temperature measuring instruments:

Add the following section: “*Water vapor content measurement.* If measurement of water vapor is required, use one of the following two methods:

“**1)** *Aspirating Psychrometer.* To measure both dry-bulb and wet-bulb temperature, construct and set up Aspirating Psychrometers as described in Section E4.1.7.

“**2)** *Dew Point Hygrometer.* Measure Dew Point temperature using a Dew Point Hygrometer as specified in Section 4 through Section 6, Section 7.1, and Section 7.4 of ASHRAE 41.6 with an accuracy of $\pm 0.4^{\circ}\text{F}$. Locate the Dew Point Hygrometer downstream of the dry-bulb temperature sensor.”

E2 The laboratory shall follow Section 6.1.2 of ASHRAE 37 with replacement of the last sentence:

“Maintain the dry-bulb temperature within the test room within $\pm 5.0^{\circ}\text{F}$ of the required dry-bulb temperature test condition for the air entering the indoor unit. The Dew Point shall be within $\pm 2^{\circ}\text{F}$ of the required inlet conditions.”

E3 The laboratory shall follow Section 6.2.7 of ASHRAE 37 with the additional references for static pressure tap positioning:

Refer to Figure 12 of ASHRAE 51/AMCA 210 or Figure 14 of ASHRAE 41.2 for guidance on placing the static pressure taps and positioning the diffusion baffle (settling means) relative to the chamber inlet.

Note: Example indoor unit installations based on different statics are shown in Figure E7a, Figure E7b, and Figure E7c. An example schematic of a test setup for ducted indoor units with common duct is shown in Figure E8.

E4 In addition to the requirements in Section 8.5 of ASHRAE 37, the laboratory shall:

In accordance with the requirements in Section E4.1 and Section E4.2, measure the indoor and outdoor air entering dry-bulb temperature and water vapor content conditions that are required be controlled for the test. When using the indoor air enthalpy method to measure equipment capacity, measure indoor air leaving dry-bulb temperature and water vapor content. When using the outdoor air enthalpy method to measure equipment capacity, measure outdoor air leaving dry-bulb temperature and water vapor content. For measuring the indoor and outdoor air leaving dry-bulb temperature and water vapor content conditions, follow the requirements in Section E4.3 in this standard. Make these measurements as described in the following sections. Maintain test operating and Test Condition Tolerances and uniformity requirements as described in Section E4.1.8.1 of this standard.

E4.1 *Outdoor Air Entering Conditions.*

For heating tests of all air-source heat pump systems, measure water vapor content in accordance with Section E1 of this standard.

E4.1.1 *General Temperature Measurement Requirements.* Temperature measurements shall be made in accordance with ASHRAE 41.1. Where there are differences between this document and ASHRAE 41.1, this document shall take precedence.

E4.1.2 *Instrument Requirements.*

E4.1.1.2.1 *Temperature Measurements.*

Follow the requirements of Table E1 of this standard. The specified accuracies shall apply to the full instrument systems including read-out devices. When using a grid of individual thermocouples rather than a thermopile, follow the thermopile temperature requirements of Table E1 in this standard.

When measuring dry-bulb temperature for sampled air within the sampled air conduit rather than with the Aspirating Psychrometer as discussed in Section E4.1.4 of this standard, use a temperature sensor and instrument system, including read-out devices, with accuracy of $\leq \pm 0.2^\circ\text{F}$ and display resolution of $\leq 0.1^\circ\text{F}$.

Table E1. Temperature Measurement Requirements		
Measurement	Accuracy, °F	Display Resolution, °F
Dry-bulb and Wet-bulb Temperatures ¹	$\leq \pm 0.2$	≤ 0.1
Thermopile Temperature ²	$\leq \pm 1.0$	≤ 0.1
Notes:		
1. The accuracy specified is for the temperature indicating device and does not reflect the operation of the Aspirating Psychrometer.		
2. To meet this requirement, thermocouple wire must have special limits of error and all thermocouple junctions in a thermopile must be made from the same spool of wire; thermopile junctions are wired in parallel.		

E4.1.3 *Air Sampling Tree Requirements.* Construct and set up at least two Air Sampling Trees. The Air Sampling Tree is intended to draw a sample of the airflow entering the air-source condenser section.

Note: An example configuration for the Air Sampling Tree is shown in Figure E1 for a tree with overall dimensions of 4 ft by 4 ft. Other sizes and rectangular shapes can be used and should be scaled accordingly as long as the aspect ratio (width to height) of less than or equal to two to one is maintained.

The Air Sampling Tree shall be constructed of stainless steel, plastic, or other durable materials and shall have a main flow trunk tube with a series of branch tubes connected to the trunk tube. The branch tubes shall have holes that are spaced and sized to provide equal airflow through the holes by increasing the hole sizes further from the trunk to account for the static pressure regain effect in the branch and trunk tubes. A minimum hole density of six holes for each square foot of area to be sampled is required. The minimum average velocity through the sampling tree holes shall be 2.5 ft/sec as determined by evaluating the sum of the open area of the holes as compared to the volume flow in the Aspirating Psychrometer or conduit connecting the Dew Point Hygrometer. The assembly shall have a standard size circular connection so that a flexible tube can be connected to the sampling tree.

The Air Sampling Tree shall be equipped with a thermocouple thermopile grid or with individual thermocouples to measure the average temperature of the airflow over the Air Sampling Tree, except as indicated in E4.1.4. The thermocouple arrangement shall have at least sixteen measuring points for each air sampling tree, evenly spaced across the Air Sampling Tree. The Air Sampling Trees shall be placed within six in to twelve in of the unit to minimize the risk of damage to the unit while verifying that the air sampling tubes are measuring the air going into the unit rather than the room air around the unit.

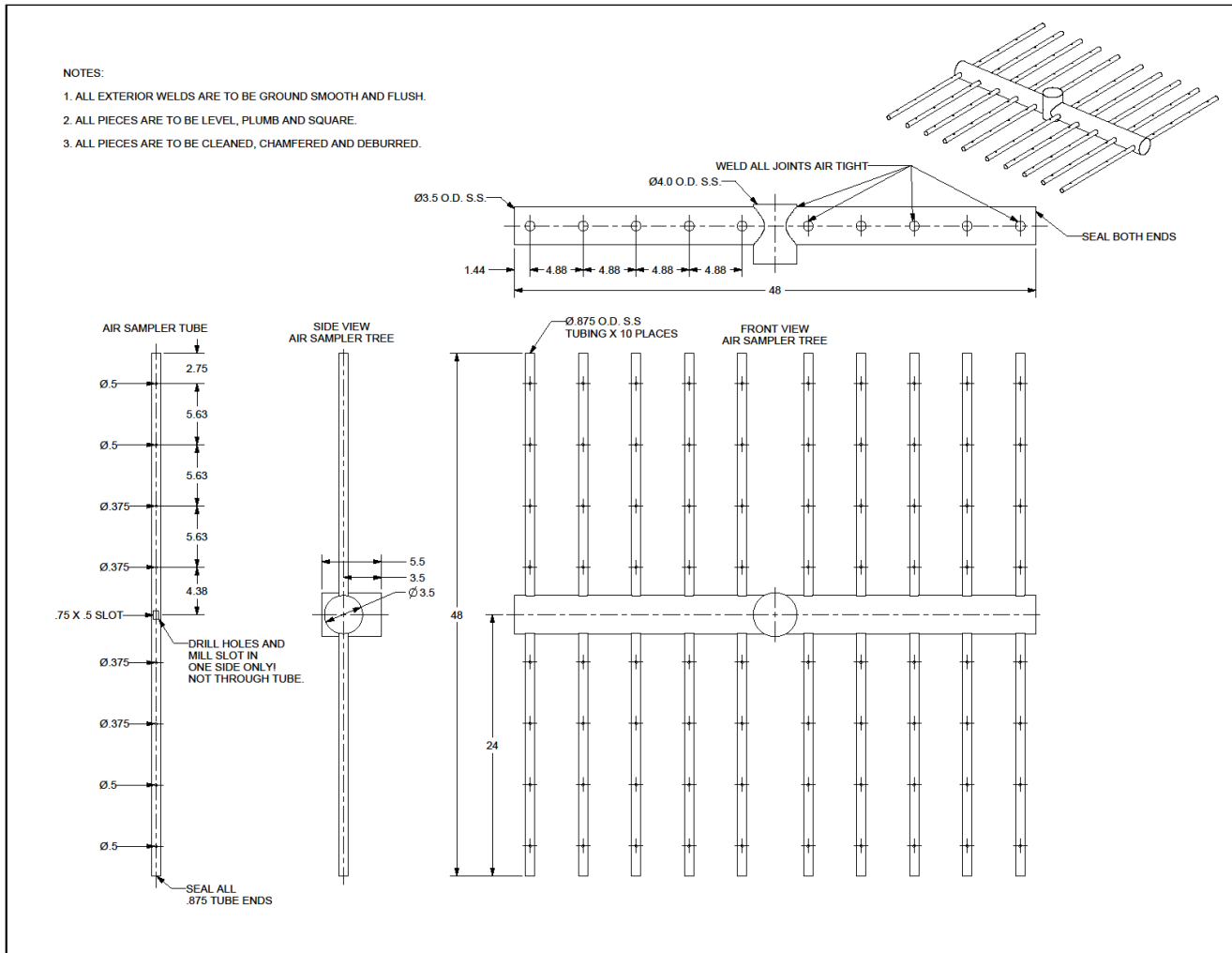

Figure E1. Example Air Sampling Tree (Informative)

E4.1.4 *Dry-bulb Temperature Measurement.* Measure dry-bulb temperatures using the Aspirating Psychrometer dry-bulb sensors, or, if not using Aspirating Psychrometer, use dry-bulb temperature sensors with accuracy as described in Section E4.1.2.1. Measure the dry-bulb temperature, upstream of the water vapor content measurement, within the conduit conducting Air Sampling Tree air to the fan that draws air through the sampling tree. When a fan draws air through more than one Air Sampling Tree, the dry-bulb temperature can be measured separately for each Air Sampling Tree or for the combined set of Air Sampling Tree flows. If dry-bulb temperature is measured at the Air Sampling Tree exit to the conduit, the use of a thermocouple thermopile grid or a grid of individual thermocouples for duplicate measurement of dry-bulb temperature is not required—use the Air Sampling Tree exit measurement when checking temperature uniformity in accordance with E4.1.8.1.

E4.1.5 *Wet Bulb or Dew Point Temperature Measurement to Determine Air Water Vapor Content.* Measure wet-bulb temperatures using two or more Aspirating Psychrometers or measure Dew Point temperature using two or more Dew Point Hygrometers. If using Dew Point Hygrometers, measure Dew Point temperature within the conduit conducting Air Sampling Tree air to the air sampling fan at a location downstream of the dry-bulb temperature measurement. When a fan draws air through more than one Air Sampling Tree, the Dew Point temperature can be measured separately for each Air Sampling Tree or for the combined set of Air Sampling Tree flows.

E4.1.6 *Monitoring and Adjustment for Air Sampling Device Conduit Temperature Change and Pressure Drop.* If dry-bulb temperature is measured at a distance from the Air Sampling Tree exits, determine average conduit temperature change as the difference in temperature between the dry-bulb

temperature and the average of thermopiles or thermocouple measurements of all Air Sampling Trees collecting air that is measured by the remote dry-bulb temperature sensor. If this difference is greater than 0.5 °F, measure dry-bulb temperature at the exit of each Air Sampling Tree as described in Section E4.1.4, and use these additional sensors to determine average entering air dry-bulb temperature.

Measure gauge pressure at the sensor location of any instrument measuring water vapor content. If the pressure differs from room pressure by more than 2 in H₂O, use this gauge pressure measurement to adjust the atmospheric pressure used to calculate the humidity ratio (in units of pounds of moisture per pound of dry air) at the measurement location.

If either the 0.5°F temperature difference threshold or the 2 in H₂O pressure difference threshold are exceeded, use a two-step process to calculate adjusted air properties such as wet-bulb temperature or enthalpy for the one or more affected Air Sampling Devices.

First, calculate the moisture level (pounds water vapor per pound dry air) at the humidity measurement location(s) using either the Aspirating Psychrometer dry-bulb and wet-bulb temperature measurements or the Dew Point Hygrometer measurement, using for either approach the adjusted pressure, if the pressure differs from the room atmospheric pressure by 2 in H₂O or more.

Second, calculate the air properties for the Air Sampling Tree location based on the moisture level, the room atmospheric pressure, and the dry-bulb temperature at the Air Sampling Tree location.

If the Air Sampling Device fan serves more than one Air Sampling Tree, and the 0.5°F threshold is exceeded, the dry-bulb temperature used in this calculation shall be the average of the Air Sampling Tree exit measurements. For multiple Air Sampling Trees, if the humidity is measured using multiple Dew Point Hygrometers, the moisture level used in this calculation shall be the average of the calculated moisture levels calculated in the first step.

E4.1.7 Aspirating Psychrometer. The Aspirating Psychrometer, shown in Figure E2, consists of a flow section to measure an average value of the sampled air stream. The flow section shall be equipped with two dry-bulb temperature probe connections. The first shall be used for the facility temperature measurement and the second shall be used to confirm this measurement using an additional or a third-party’s temperature sensor probe. For applications where the humidity is required for testing of Heat Pumps in heating mode, the flow section shall be equipped with two wet-bulb temperature probe connection zones. The first shall be used for the facility wet-bulb measurement and the second shall be used to confirm the wet-bulb measurement using an additional or a third-party’s wet-bulb sensor probe.

“The Aspirating Psychrometer shall be connected to a fan to draw air through the flow section that either can be adjusted manually or automatically to maintain required velocity across the sensors.

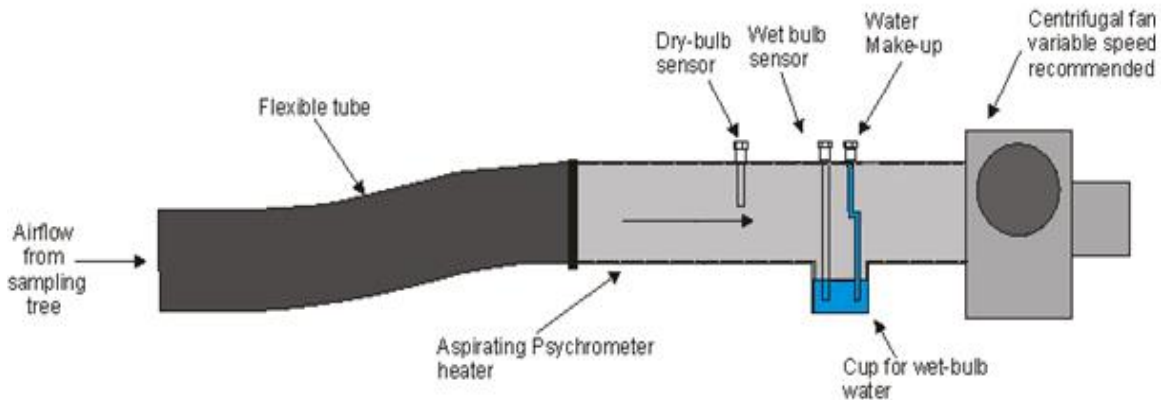

Figure E2. Example of an Aspirating Psychrometer (Informative)

E4.1.8 *Test Setup Description.* The nominal face area of the airflow through the Air Sampling Tree(s) shall be divided into equal area sampling rectangles with aspect ratios that are not greater than 2:1. The nominal face area can extend beyond the coil depending on coil configuration and orientation, and shall include all regions where air enters the unit. Use one of the following two approaches:

- 1) Each rectangular area shall have one Air Sampling Tree. A minimum of one Aspirating Psychrometer for each side of a VRF Multi-split System shall be used. Additional Aspirating Psychrometers shall be used to meet the maximum requirement of four Air Sampling Trees for each Aspirating Psychrometer. For units that have air entering the sides and the bottom of the unit, additional Air Sampling Trees shall be used; or
- 2) A minimum of two Aspirating Psychrometers or Dew Point Hygrometers shall be used, except as described in Section E4.3.6. The largest rectangular area for each individual unit shall have at least one Air Sampling Tree. Additional Air Sampling Trees shall be used on the next largest rectangular area. For multiple modules that require more than eight Air Sampling Trees, install a grid of evenly distributed thermocouples on each rectangular area when an Air Sampling Tree is not installed. The thermocouples shall be evenly spaced across the rectangular area and be installed to minimize sampling of discharge air or blockage of air recirculation. The grid of thermocouples shall provide at least sixteen measuring points for each rectangular area, evenly spaced across the rectangular area. This grid shall be placed within six in of the unit.

The Air Sampling Trees shall be located at the geometric center of each rectangle area that the Air Sampling Trees are sampling; the branches can be oriented either parallel or perpendicular to the longer edges of the air inlet area. The Air Sampling Tree(s) in the outdoor air inlet location shall be sized in such a manner that the Air Sampling Tree(s) cover at least 80% of the height and 60% of the width of the air entrance to the unit (for long horizontal coils), or shall cover at least 80% of the width and 60% of the height of the air entrance (for tall vertical coils). The Air Sampling Tree can be larger than the face area of the side being measured; however, discharge air shall not be sampled. If an Air Sampling Tree dimension extends beyond the inlet area of the unit, holes shall be blocked in the Air Sampling Tree to prevent sampling of discharge air. Holes can be blocked to reduce the region of coverage of the intake holes both in the direction of the trunk axis or perpendicular to the trunk axis. For intake hole region reduction in the direction of the trunk axis, block holes of one or more adjacent pairs of branches (the branches of a pair connect opposite each other at the same trunk location) at either the outlet end or the closed end of the trunk. For intake hole region reduction perpendicular to the trunk axis, block off the same number of holes on each branch on both sides of the trunk. A maximum of four Air Sampling Trees shall be connected to each Aspirating Psychrometer. To proportionately divide the flow stream for multiple Air Sampling Trees for a given Aspirating Psychrometer, the tubing or conduit conveying sampled air to the Aspirating Psychrometer shall be of equal lengths for each Air Sampling Tree. Examples of Single Module and Combined Module Air Sampling Tree placement are shown in Figure E3 and Figure E4, respectively.

E4.1.8.1 *Temperature Uniformity.* The room and test setup shall be designed and operated for the necessary air distribution, thorough mixing, and uniform air temperature. The room conditioning equipment airflow shall be set such that recirculation of condenser discharged air is prevented except as can naturally occur from the equipment. To check for the recirculation of condenser discharged air back into the condenser coil(s) the following method shall be used: Multiple individual reading thermocouples (at least one for each sampling tree location) shall be installed around the unit air discharge perimeter so that the thermocouples are beneath the plane of the condenser fan exhaust and just above the top of the condenser coil(s). These thermocouples shall not indicate a temperature difference greater than 5.0°F from the average inlet air. Air distribution at the test facility at the point of supply to the unit shall be reviewed to determine if the air distribution requires remediation prior to beginning testing.

Mixing fans can be used for ample air distribution in the test room. If used, mixing fans shall be oriented to point away from the air intake so that the mixing fan exhaust direction is at an angle between 90° and 270° to the air entrance to the condenser air inlet.

When not using Aspirating Psychrometers, the ‘Aspirating Psychrometer dry-bulb temperature measurement’ of Table E2 refers to either (a) the dry-bulb temperature measurement in a single common air conduit serving one or more Air Sampling Trees or (b) the average of the dry-bulb temperature measurements made separately for each of the Air Sampling Trees served by a single Air Sampling Device fan. Comparably, ‘wet-bulb temperature’ refers to calculated wet-bulb temperatures based on Dew Point measurements.

Adjust measurements if required by Section E4.1.6 prior to checking uniformity.

The 1.5°F dry-bulb temperature tolerance in Table E2 between the Air Sampling Tree thermopile (thermocouple) measurements and Aspirating Psychrometer measurements only applies when more than one Air Sampling Tree serves a given Aspirating Psychrometer.

The uniformity requirements apply to test period averages rather than instantaneous measurements.

When water vapor content measurement is required and approach (1) from Section E4.1.8 is used, confirm uniformity of wet-bulb temperature variation among all Aspirating Psychrometers.

A valid test shall meet the criteria for the necessary air distribution and control of air temperature as shown in Table E2.

Table E2. Criteria for Air Distribution and Control of Air Temperature		
Dry-bulb Temperature	Purpose	Maximum Variation, °F
Deviation from the mean air dry-bulb temperature to the air dry-bulb temperature at any individual temperature measurement station ¹	Uniform temperature distribution	± 2.00
Difference between dry-bulb temperature measured with Air Sampling Tree thermopile and with Aspirating Psychrometer	Uniform temperature distribution	± 1.50
Difference between mean dry-bulb air temperature and the specified target test value ²	Test Condition Tolerance, for control of air temperature	± 0.50
Mean dry-bulb air temperature variation over time (from the first to the last of the data sets)	Test Operating Tolerance, total observed range of variation over data collection time	± 1.50
Wet-bulb Temperature³	Purpose	Maximum Variation, °F
Deviation from the mean wet-bulb temperature and the individual temperature measurement stations	Uniform humidity distribution	± 1.00
Difference between mean wet-bulb air wet-bulb temperature and the specified target test value ²	Test Condition Tolerance, for control of air temperature	± 1.00
Mean wet-bulb air temperature variation over time	Test Operating Tolerance, total observed range of variation over data collection time (from the first to the last of the data sets)	± 1.00
Notes: 1. Each measurement station represents an average value as measured by a single Aspirating Psychrometer. 2. The mean dry-bulb temperature is the mean of all measurement stations. 3. The wet-bulb temperature measurement is only required for Heat Pumps operating in the heating mode.		

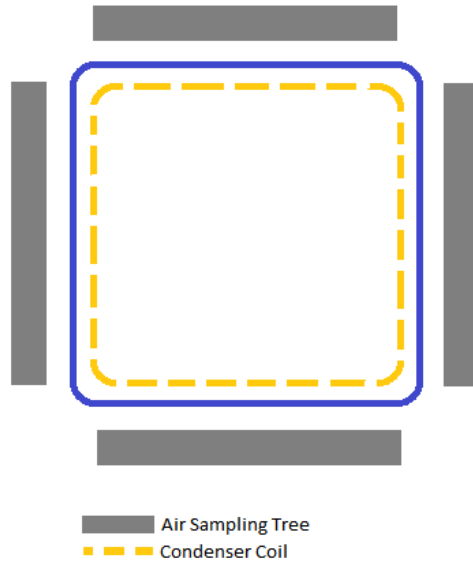

Figure E3. Single Module Air Sampling Tree Placement Example (Informative)



Figure E4. Multiple Module Air Sampling Tree Placement Example (Informative)

E4.2 *Indoor Coil Entering Air Conditions.*

Follow the requirements for outdoor coil entering air conditions as described in Section E4.1, except that:

- Both dry-bulb temperature and water vapor content measurements are required for all tests;
- Sampled air shall be returned to the room from where the system draws the indoor coil entering air, except if the loop air enthalpy test method specified in Section 6.1.2 of ASHRAE 37 is used. In these cases, the sampled air shall be returned upstream of the Air Sampling Tree in the loop duct between the airflow-measuring apparatus and the room conditioning apparatus; and
- If air is sampled within a duct, the Air Sampling Tree shall be installed with the rectangle defined by the Air Sampling Tree inlet holes oriented parallel with and centered in the duct cross section. This rectangle shall have dimensions that are at least 75% of the duct's respective dimensions.

Additionally, if an inlet plenum is not connected to the air inlet during testing, for example, for a non-ducted indoor unit other than ceiling cassette, set up Air Sampling Tree(s) as described in Section E4.1.8 and locate an Air Sampling Tree with dry-bulb temperature measurement 5 in to 7 in upstream from the inlet of each indoor coil that is being sampled.

E4.3 *Indoor Coil Leaving Air and Outdoor Coil Leaving Air Conditions.*

Follow the requirements for measurement of outdoor coil entering air conditions as described in Section E4.1, except for the following:

E4.3.1 The temperature uniformity requirements discussed in Section E4.1.8(1) do not apply.

E4.3.2 Both dry-bulb temperature and water vapor content measurements are required for indoor coil leaving air for all tests and for outdoor coil leaving air for all tests using the outdoor air enthalpy method.

E4.3.3 Air in the duct leaving the coil that is drawn into the Air Sampling Tree for measurement shall be returned to the duct just downstream of the Air Sampling Tree and upstream of the airflow-measuring apparatus. If an independent dry-bulb temperature measurement is conducted at the nozzle location, insulate the conduit transferring the air from the Air Sampling Device fan discharge to the duct.

E4.3.4 For a coil that is equipped with a blow-through fan, where the fan is located upstream of the coil, use a grid of individual thermocouples rather than a thermopile on the Air Sampling Tree, even if Air Sampling Tree exit dry-bulb temperature measurement instruments are installed. If the difference between the maximum time-averaged thermocouple measurement and the minimum time-averaged thermocouple measurement is greater than 1.5°F, install mixing devices such as those described in Section 5.3.2 and Section 5.3.3 of ASHRAE 41.1 to reduce the maximum temperature spread to less than 1.5°F.

E4.3.5 The Air Sampling Tree (used within the duct transferring air to the airflow measurement apparatus) shall be installed with the rectangle defined by the Air Sampling Tree inlet holes oriented parallel with and centered in the duct cross section—this rectangle shall have dimensions that are at least 75% of the duct's respective dimensions.

E4.3.6 If a single common outlet plenum is used, only one Aspirating Psychrometer is required.

E5 The laboratory shall follow Section 6.4.2 of AHSRAE 37 with the following addition:

For VRF ducted Indoor Units, except Small-duct, High-velocity, an inlet duct equaling the size of the combined inlet opening of all indoors rated at the same static with a length of 6 in to 24 in shall be installed. A static pressure tap shall be in the center of each face. This inlet duct shall be connected directly to the inlet of the unit.

E6 For Small-duct, High-velocity Systems the laboratory shall follow Section 6.4.3 of ASHRAE 37 with the following addition:

Install an outlet plenum that has a diameter that is equal to or less than the value listed in Table E3. The limit depends only on the cooling full-load air volume rate regardless of the flange dimensions on the outlet of the unit or an air supply plenum adapter accessory, if installed in accordance with the MII.

Table E3. Outlet Plenum Maximum Diameter	
Cooling Full-Load Air Volume Rate, scfm	Maximum Diameter ¹ of Outlet Plenum, in
≤ 500	6
501 to 700	7
701 to 900	8
901 to 1100	9
1101 to 1400	10
1401 to 1750	11
Note: 1. If the outlet plenum is rectangular, calculate the plenum's estimated diameter using $(4A)/P$, where A is the area and P is the perimeter of the rectangular plenum, and compare this value to the listed maximum diameter.	

E7 For Static Pressure Measurement, the laboratory shall follow Section 6.5 of ASHRAE 37 with these additions:

E7.1 Indoor coil static pressure difference measurement. Connect one side of the differential pressure instrument to the manifolded pressure taps installed in the outlet plenum. Connect the other side of the instrument to the manifolded pressure taps located in the inlet plenum. For Non-ducted Systems that are tested with multiple outlet plenums, measure the static pressure within each outlet plenum relative to the surrounding atmosphere.

E7.2 Test Set-up on the Outlet Side of The Indoor Coil. Static pressure measurement on the outlet side of the coil shall be setup in the following manner:

- 1) Install an interconnecting duct between the indoor coil outlet plenum and the airflow measuring apparatus. If needed, use adaptor plates or transition duct sections to make the connections. To minimize leakage, tape joints within the interconnecting duct (and the outlet plenum). Construct or insulate the entire flow section with thermal insulation having a nominal overall resistance (R-value) of at least 19 hr·ft² °F/Btu.
- 2) Install a grid(s) of dry-bulb temperature sensors inside the interconnecting duct and install an Air Sampling Tree, or the sensor(s) used to measure the water vapor content of the outlet air, inside the interconnecting duct. Locate the dry-bulb temperature grid(s) upstream of the Air Sampling Tree (or the in-duct sensor(s) used to measure the water vapor content of the outlet air). Air that circulates through an Air Sampling Tree and past a remote water-vapor-content sensor(s) shall be returned to the interconnecting duct at a point:
 - Downstream of the Air Sampling Tree;
 - Upstream of the outlet air damper box, if installed; and
 - Upstream of the airflow measuring apparatus.

E7.3 Minimizing Air Leakage. For SDHV, install an air damper as close to the end of the interconnecting duct as can be achieved, just prior to the transition to the airflow measuring apparatus. To minimize air leakage, adjust this damper such that the pressure in the receiving chamber of the airflow measuring apparatus is not greater than 0.5 in H₂O higher than the surrounding test room ambient. Instead of installing a separate damper, use the outlet air damper box if the outlet damper box enables variable positioning. Apply these steps to any conventional indoor blower unit that creates a static pressure within the receiving chamber of the airflow measuring apparatus that exceeds the test room ambient pressure by more than 0.5 in H₂O.

E7.4 Static Pressure Tap Locations. Add a static pressure tap to each face of each outlet plenum, if rectangular, or at four evenly distributed locations along the circumference of an oval or round plenum. A manifold that connects the four static pressure taps shall be provided. Figure E5 shows options for the manifold configuration.

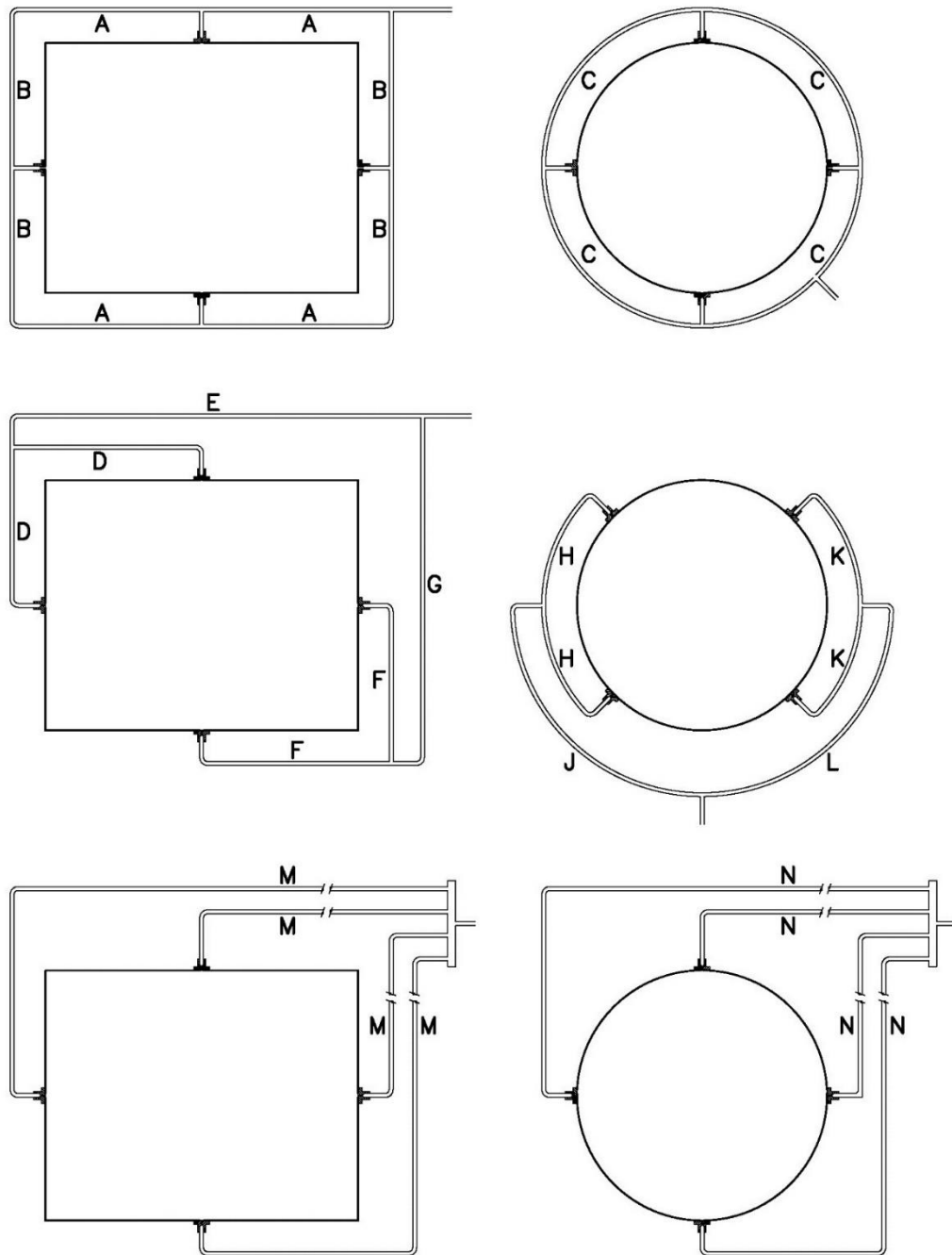

Figure E5. Example Configurations for Manifolding the Static Pressure Taps (Informative)

E8 The laboratory shall follow Section 6.6.1 of ASHRAE 37 for duct insulation requirements with the addition that the outlet plenum shall have thermal insulation that has a nominal overall resistance (R-value) of at least $19 \text{ hr} \cdot \text{ft}^2 \text{ } ^\circ\text{F}/\text{Btu}$.

E9 For the secondary capacity check, the laboratory shall follow Section 7.2 of ASHRAE 37. If using the outdoor air enthalpy method as a secondary verification, only the high temperature full load tests for cooling and heating mode require a secondary capacity check. For all other tests in each mode of operation, a secondary capacity check is not required.

E10 For multiple modules, the laboratory shall follow Section 7.6 of ASHRAE 37 and, in addition, the liquid flow rate, temperature and pressure measurements shall apply for each module individually. Temperature measurements shall be made within 6 in of each liquid inlet and within 24 in of each liquid outlet.

E11 For interconnecting tubing the laboratory shall follow Section 8.2.4 of ASHRAE 37. In addition, the laboratory shall at a minimum insulate all interconnecting vapor line(s) of a split-system with insulation having an inside diameter that matches the refrigerant tubing and an R value between 4 to 6 hr·ft² °F/Btu.

E12 For outdoor air enthalpy measurement the laboratory shall follow Section 8.6 of ASHRE 37 and meet the following additional requirements:

E12.1 *General.* When using the outdoor air enthalpy method as the secondary method for capacity measurement, first conduct a test without the outdoor air-side test apparatus connected to the Outdoor Unit (“free outdoor air” test). Then attach the outdoor air-side test apparatus and conduct a test with the apparatus connected to the Outdoor Unit (“ducted outdoor air” test). Use the indoor air enthalpy method capacity measurements and power input measurements to determine the efficiency metrics, provided the conditions of Section E12.2.4 are met.

E12.2 *Free Outdoor Air Test.* For the free outdoor air test, connect the indoor air-side test apparatus to the indoor coil; do not connect the outdoor air-side test apparatus. The test room reconditioning apparatus and the unit being tested shall operate for at least one hour.

E12.2.1 After attaining equilibrium conditions, measure the following quantities at equal intervals that span 5 minutes or less:

E12.2.1.1 The evaporator and condenser temperatures or pressures;

E12.2.1.2 Parameters required according to the indoor air enthalpy method (as specified in Section 7.3 of ASHRAE 37).

E12.2.2 Continue these measurements until seven consecutive five-minute samples over a thirty-minute period are obtained where the applicable test tolerances are satisfied.

E12.2.3 *Evaporator and Condenser Measurements.* To measure evaporator and condenser temperatures, solder a thermocouple onto a return bend located at or close to the midpoints of each coil or at points not affected by vapor superheat or liquid subcooling. Alternatively, if the test unit is not sensitive to the refrigerant charge, install pressure gauges to the access valves or to ports created from tapping into the suction and discharge lines according to Section 7.4.2 and Section 8.2.5 of ASHRAE 37. The alternative approach shall be used when testing a unit charged with a zeotropic refrigerant having a temperature glide greater than 1°F at the specified test conditions.

E12.2.4 For the free outdoor air test to constitute a valid test for determination of efficiency metrics, the following conditions shall be met:

- For the ducted outdoor test, the capacities determined using the outdoor air enthalpy method and the indoor air enthalpy method shall agree within 6%.
- The capacities determined using the indoor air enthalpy method from the ducted outdoor air and free outdoor air tests shall agree within 2%.
- “The average of coil midpoint or pressure-equivalent saturation temperatures shall agree within 0.5°F.

E12.3 *Ducted Outdoor Air Test*

E12.3.1 After collecting thirty minutes of steady-state data during the free outdoor air test, connect the outdoor air-side test apparatus to the unit for the ducted outdoor air test. Adjust the exhaust fan of the outdoor air-side test apparatus until averages for the evaporator and condenser temperatures, or the saturated temperatures corresponding to the measured pressures, agree within ± 0.5°F of the averages achieved during the free outdoor air test. Collect thirty minutes of steady-state data where the applicable test tolerances are satisfied.

E12.3.2 During the ducted outdoor air test, at intervals of five minutes or less, measure the parameters required according to the indoor air enthalpy method and the outdoor air enthalpy method for the prescribed thirty minutes.

E12.3.3 For cooling mode ducted outdoor air tests, calculate capacity based on outdoor air enthalpy measurements as specified in Section 7.3.3.2 and Section 7.3.3.3 of ASHRAE 37. For heating mode ducted tests, calculate Heating Capacity based on outdoor air-enthalpy measurements as specified in Section 7.3.4.2 and Section 7.3.4.3 of ASHRAE 37. Adjust the outdoor-side capacity according to Section 7.3.3.4 of ASHRAE 37 to account for line losses when testing Split Systems. Use the outdoor airflow rate as measured during the ducted outdoor air test to calculate capacity for checking the agreement with the capacity calculated using the indoor air enthalpy method during the ducted outdoor test.

E13 For measuring indoor inlet dry-bulb temperature and water vapor content, the laboratory shall follow Section 8.5.3 of ASHRAE 37. In addition, when there are multiple Non-Ducted Indoor Units, locate a grid 5 in to 7 in upstream from the inlet of each indoor unit.

Note: An example of a VRF Multi-split Systems setup is shown in Figure E11.

E14 For multiple speed outdoor fan motors, the laboratory shall follow Section 8.7 of ASHRAE 37. In addition, the controls of the unit shall regulate the operation of the outdoor fan during all laboratory tests except dry coil cooling mode tests. For dry coil cooling mode tests, the outdoor fan shall operate at the same speed used during the required wet coil test conducted at the same outdoor test conditions.

E15 The laboratory shall follow Section 8.8.2.3 and Section 8.8.3.4 of ASHRAE 37, except that the length of the tests shall be reduced to not less than 30 minutes. When the heating test is at the frosting condition, there is not a minimum test length.

E16 For capacity tests, the laboratory shall follow Section 10.1.2 of ASHRAE 37. In addition, for the capacity comparison, use the indoor air enthalpy method capacity that is calculated in Section 7.3.3 and Section 7.3.4 of ASHRAE 37.

Note: Capacity comparison is often referred to as heat balance or energy balance.

E17 For static pressure measurements across indoor coils, the laboratory shall follow Section 8 of ASHRAE 37. In addition, for systems having multiple indoor coils or multiple indoor blowers within a single indoor section, attach a plenum to each indoor coil or blower outlet. Connect two or more outlet plenums to a single common duct so that each indoor coil ultimately connects to an airflow measuring apparatus.

If using more than one indoor test room, perform the same steps, creating one or more common ducts within each test room that contains multiple indoor coils. At the plane where each plenum enters a common duct, install an adjustable airflow damper, and use the damper to equalize the static pressure in each plenum. Each outlet air temperature grid and airflow measuring apparatus are located downstream of the inlet(s) to the common duct.

E18 For wall-mount and Ducted Indoor Units the laboratory shall follow Section 8.3. of ASHRAE 37 with the following additions:

A plenum (enlarged duct box) shall be installed between the duct and the indoor unit(s). The plenum shall have a cross-sectional area at least two times the area of the indoor unit(s) combined outlet. For all outlets, the plenum shall extend for a distance of at least three and one-half times the square root of the cross-sectional area of the indoor unit(s) combined outlet prior to any duct transitions, elbows, or Air Sampling Trees used for air condition measurement, and shall meet the following:

- If used, elbows connected to the end of the plenum shall have a centerline radius equal to at least one and one-half times the duct width in the radial direction or have turning vanes. Air velocities calculated as measured volume flow divided by duct or plenum cross-sectional area shall not exceed 250 ft/min inside the plenum and 500 ft/min in the connecting duct at the connecting duct's connection to the plenum.
- Manifolded static pressure taps shall be installed in the plenum in at least four locations spaced uniformly around the plenum in accordance with Section 6.5 of ASHRAE 37. The static pressure taps shall be 2.8 times the square root of the cross-sectional area of the combined outlets from the indoor unit(s).
- Air Sampling Trees used for indoor air leaving property measurement shall be placed in the duct between the airflow measurement apparatus and the minimum required plenum length.
- The plenum shall not interfere with the throw angle.

- Air velocities calculated as measured volume flow divided by duct or plenum cross-sectional area shall not exceed 250 ft/min inside the plenum.

Note: An example of a setup for Wall-mounted Indoor Units is shown in Figure E6.

- Air Sampling Trees used for temperature measurement shall be placed in the duct between the airflow measurement apparatus and the minimum required plenum length.

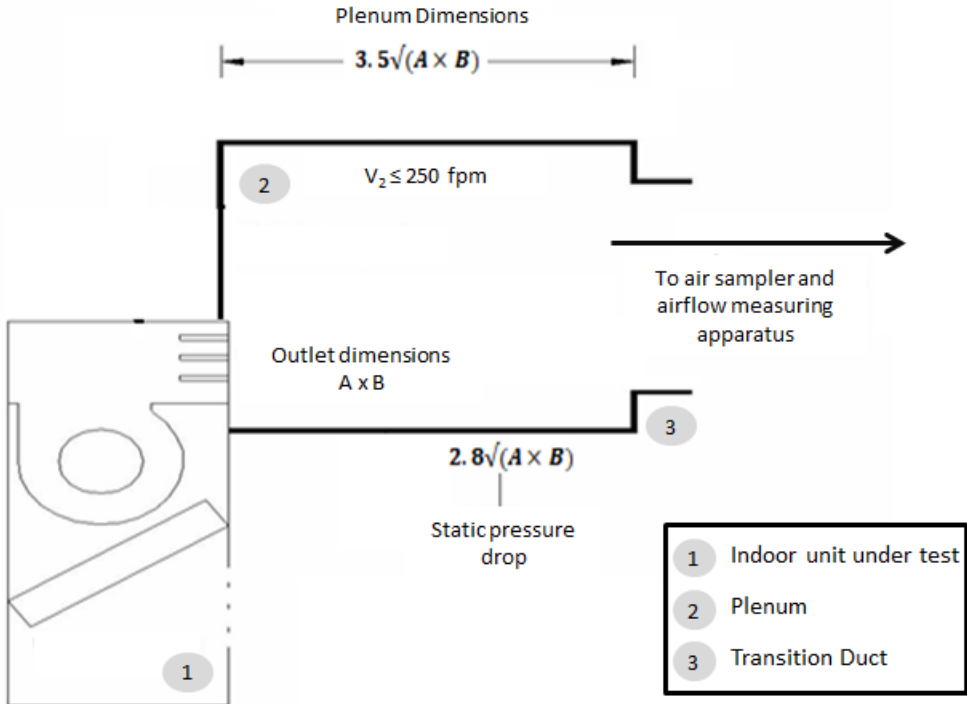

Figure E6. Example Setup for Wall Mounted Indoor Units (Informative)

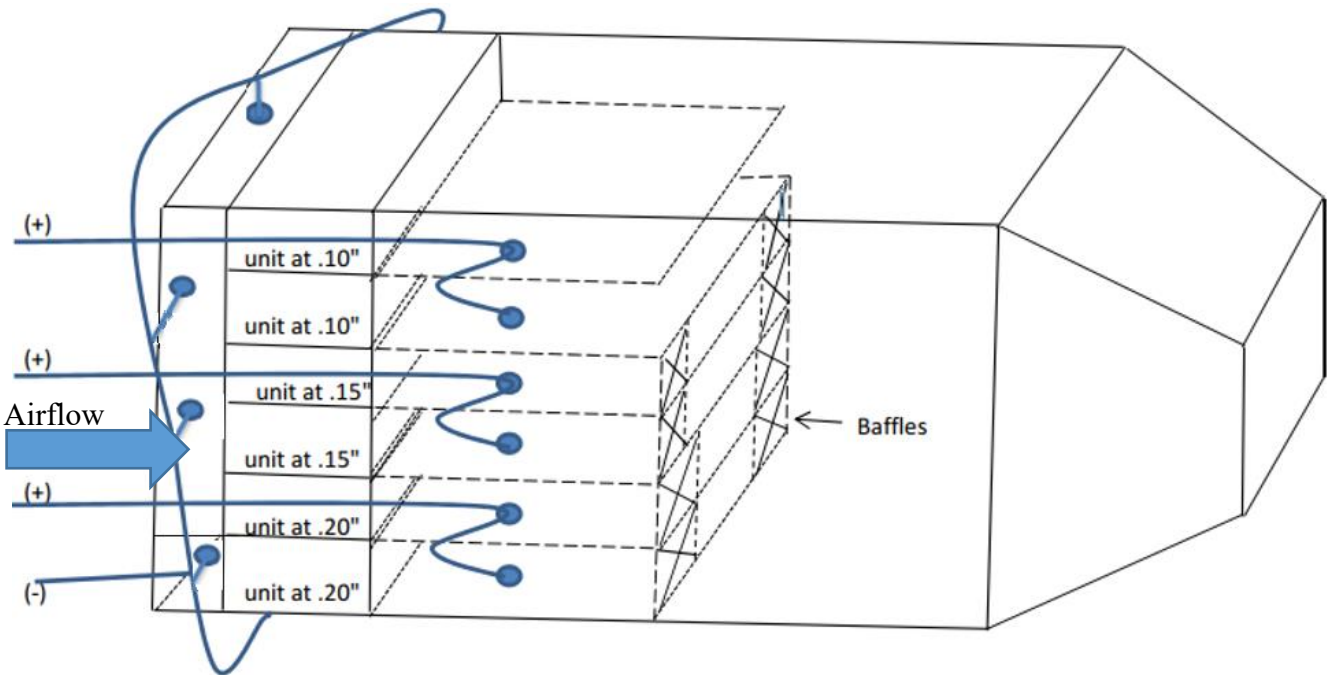

Figure E7a. Example Indoor Units Installation Based on Different Static Pressures (Informative)

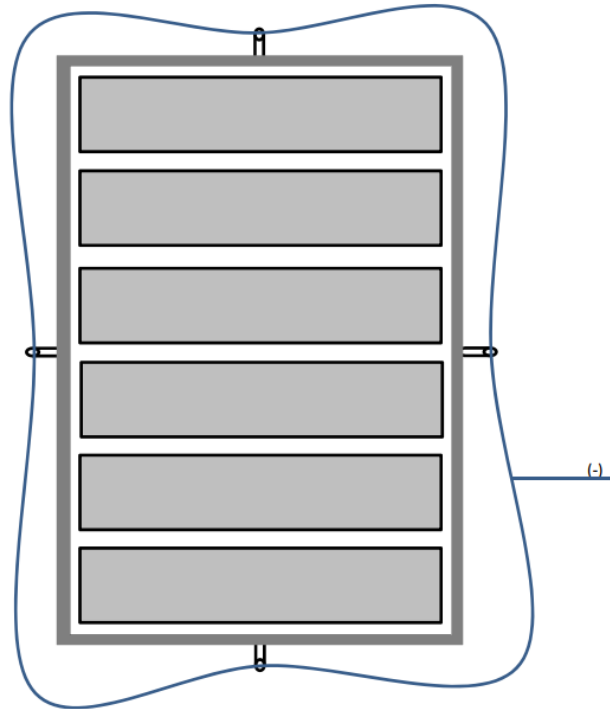

Figure E7b. Example Indoor Units Installation for IDUs of Same Chassis Size (Informative)

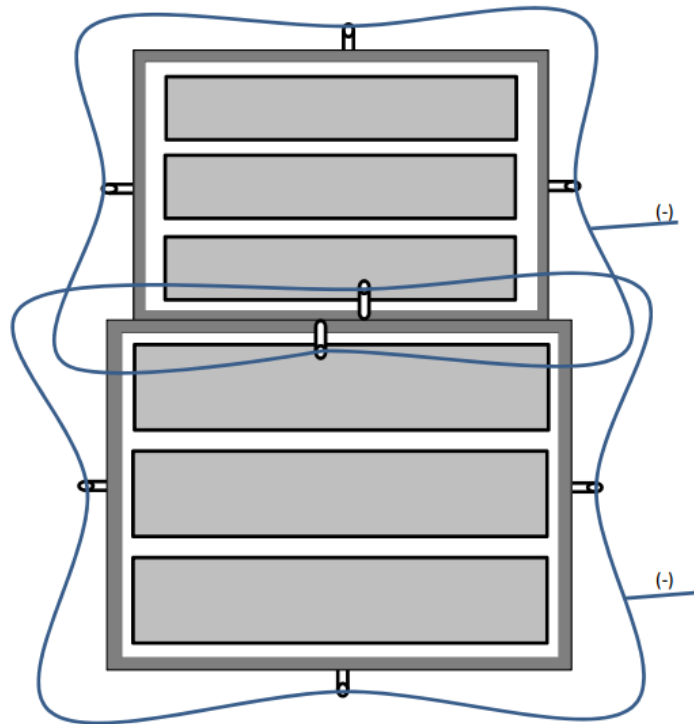

Figure E7c. Example Indoor Units Installation for IDUs of Different Chassis Size (Informative)

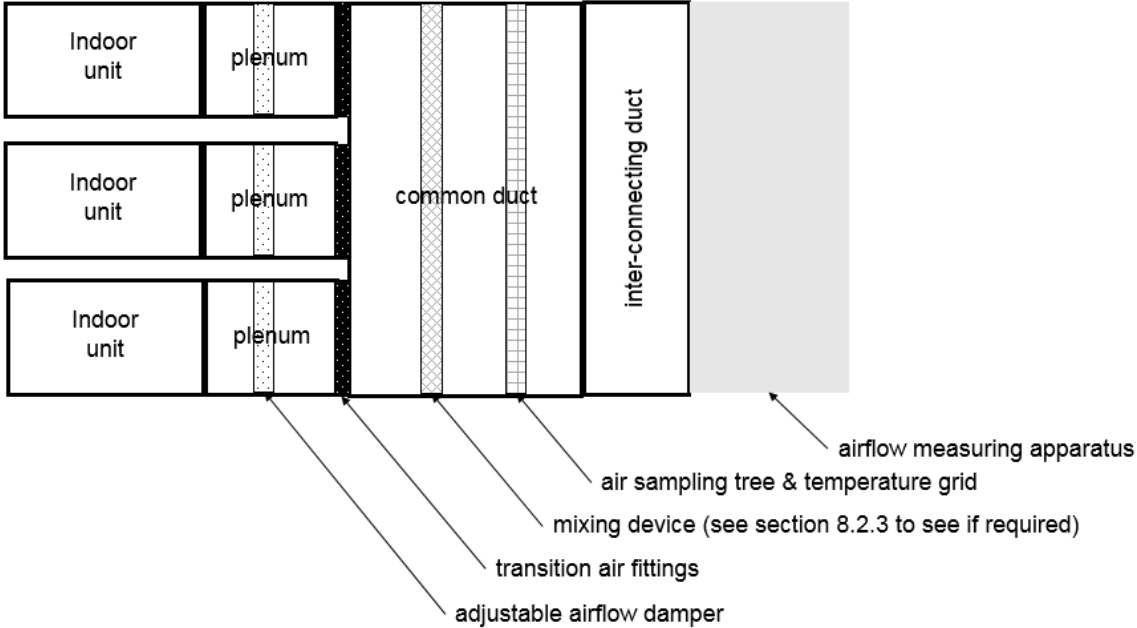

Figure E8. Schematic of Example Test Setup for Ducted Indoor Units with Common Duct (Informative)

E19 For wall-mount and Ducted Indoor Units the laboratory shall follow Section 8.3. of ASHRAE 37 with these additional requirements:

An inlet plenum shall not be used when testing a non-ducted units that are not Ceiling Cassettes. If an inlet plenum is used for Ceiling Cassettes, the inlet plenum shall have a cross-sectional area at least two times the area of the Ceiling Cassette(s) combined inlet.

Note: Examples of indoor return air property measurements for Ceiling Cassettes are shown in Figure E9a, Figure E9b, and Figure E10.

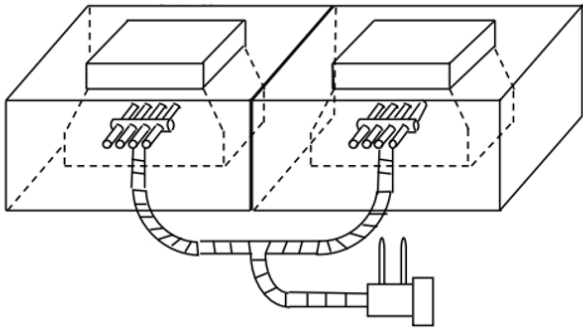

Figure E9a. Example Return Air Measurement Setup for Non-Ducted Units, Sampling Tree at Unit (Informative)

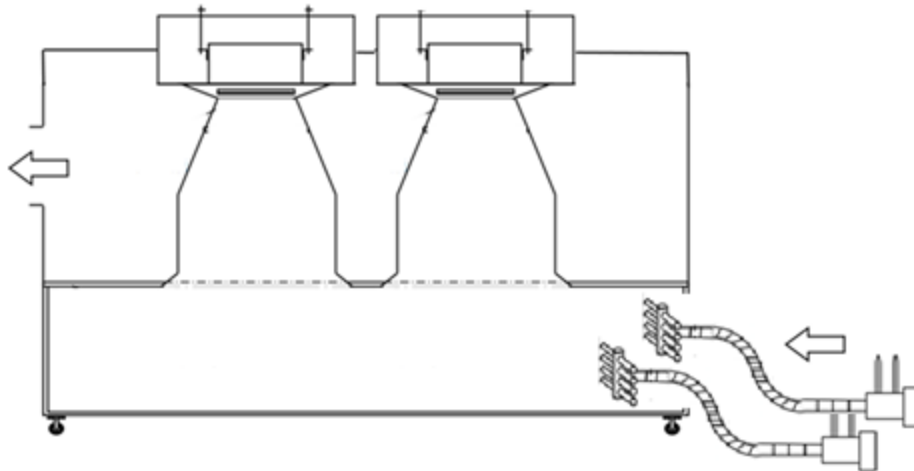

Figure E9b. Example Return Air Measurement Setup for Non-Ducted Units, Sampling Tree Common (Informative)

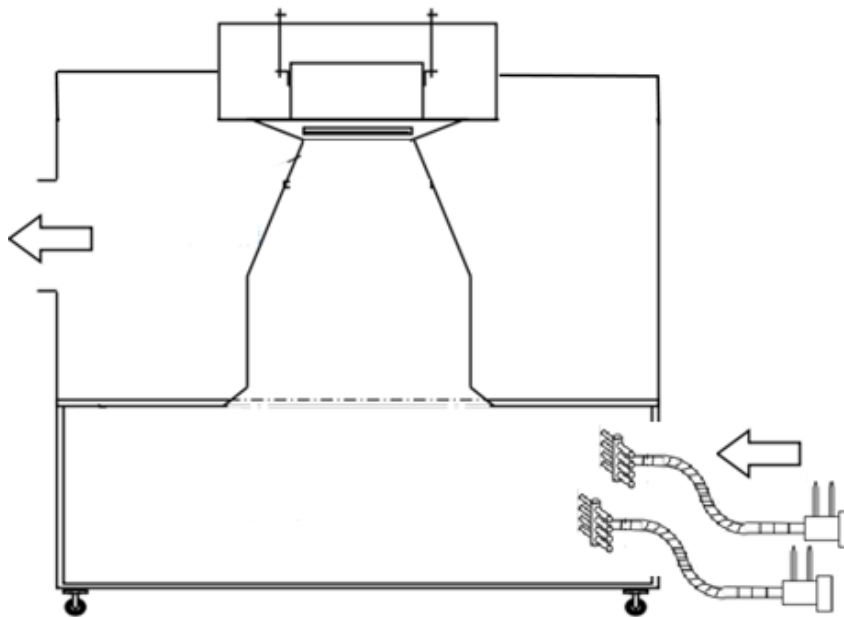

Figure E10. Example Return Air Measurement Setup for Ceiling Cassette (Informative)

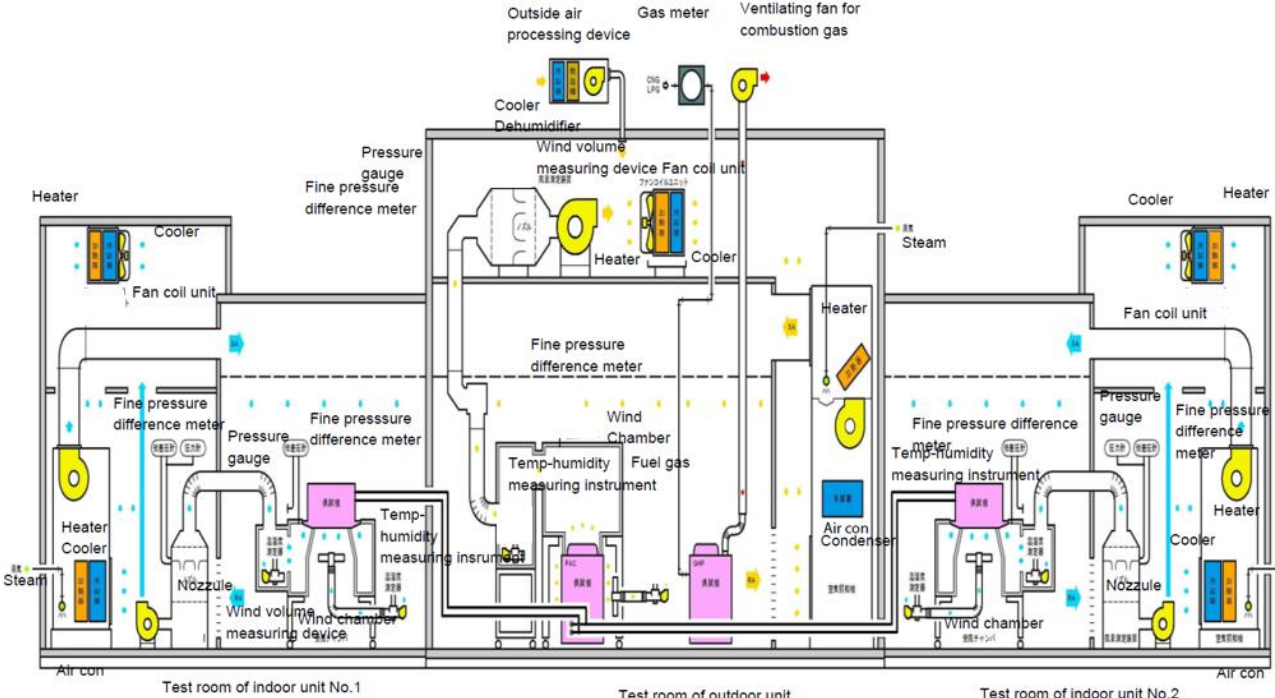

Figure E11. Example VRF System Setup in Laboratory (Informative)

APPENDIX F. UNIT CONFIGURATION FOR STANDARD EFFICIENCY DETERMINATION – NORMATIVE

F1 *Purpose.* This appendix prescribes the requirements for the configuration of a unit to be used for determining the Standard Rating Cooling and Heating Capacity and efficiency metrics. Certain requirements reduce burden by streamlining the amount of testing done by manufacturers to rate their products.

F2 *Configuration Requirements.* For Standard Ratings, units shall be configured for testing as defined in this appendix.

F2.1 The following components shall be present and installed on each Indoor Unit and Outdoor Unit for all testing, as applicable:

- Indoor air filter(s)
 - *Ducted Indoor Units.* Test without a filter and increase the applicable value in Table 7 by 0.08 in H₂O.
 - *Non-ducted Indoor Units.* Test with filter as shipped from the factory.
- Compressor(s)
- Outdoor coil(s) or heat exchanger(s)
- Outdoor fan/motor(s) (Air-source systems only)
- Indoor coil(s)
- Refrigerant expansion device(s)
- Indoor fan/motor(s)
- System Controls

Auxiliary heating or heat recovery components or both shall be present and installed for testing individual models distributed in commerce with these components.

F2.2 *Optional System Features.* The following features are optional for installation during testing if an otherwise identical individual model without the feature is sold. If an otherwise identical individual model without the feature is not sold, follow the provisions provided in Section F2.2.1 through Section F2.2.8 regarding whether and how to remove the feature and test or leave the feature installed and test:

F2.2.1 *Economizers.* If an otherwise identical individual model without an economizer is not sold, test with the economizer installed with outside air dampers fully sealed.

F2.2.2 *Ventilation Energy Recovery System (VERS).* Energy recovery devices recover energy from the ventilation or exhaust air and provide annualized energy efficiency improvements depending on the regional ambient and building operating load conditions. VERS are not identified in the IEER metric and are addressed separately by AHRI Guideline V. If an otherwise identical individual model without a VERS is not sold, test with the VERS installed with outside air dampers fully sealed.

F2.2.3 *Desiccant Dehumidification Components.* If an otherwise identical individual model without desiccant dehumidification components is not sold, test with the desiccant dehumidification components installed and disabled.

F2.2.4 *Power Correction Capacitors.* Power Correction Capacitors are a requirement of the power distribution system supplying the unit. If an otherwise identical individual model without power correction capacitors is not sold, power correction capacitors can be removed for testing.

F2.2.5 *Hail Guards.* If an otherwise identical individual model without hail guards is not sold, hail guards can be removed for testing.

F2.2.6 *Fresh Air Dampers.* If an otherwise identical individual model without fresh air dampers is not sold, test with the fresh air dampers installed and fully sealed.

F2.2.7 *Low Ambient Cooling Dampers.* If an otherwise identical individual model without low ambient cooling dampers is not sold, low ambient cooling dampers can be removed for testing.

F2.2.8 *Steam or Hydronic Coils.* If an otherwise identical individual model without steam or hydronic coil is not sold, test with the steam or hydronic coil installed and disabled.

APPENDIX G. EXAMPLES OF IEER CALCULATIONS – INFORMATIVE

G1 *IEER Background.* The IEER has been developed to represent a single metric for the annualized performance of the mechanical cooling system and is based on a volume weighted average of three building types and seventeen climate zones, and includes four rating points at 100%, 75%, 50% and 25% load at condenser conditions seen during these load points. The IEER includes all mechanical cooling energy, fan energy, and other energy required to deliver mechanical cooling. The IEER excludes energy and cooling capacity for operating hours seen for just ventilation, economizer operation, and does not include System Control options such as demand ventilation, Supply Air reset, energy recovery, and other system options that can be used in an applied configuration of the unit. IEER assumes that the unit is not oversized. The metric provides a comparison of mechanical cooling systems at a common industry set of conditions.

Building energy consumption varies based on factors including, but not limited to, local occupancy schedules, ambient conditions, building construction, building location, ventilation requirements, and added features such as economizers, energy recovery, and evaporative cooling. IEER is comparative metric representing the integrated full load and part-load annualized performance of the mechanical cooling of the air-conditioning unit over a range of operating conditions. IEER is not intended to be a predictor of the annual energy consumption of a specific building in a given climate zone. An energy analysis using an hour-by-hour analysis program should be performed for the intended building using the local weather data to estimate the energy consumption of a specific building.

G2 *Example Calculations for Different Compressor and Fan Types.* This appendix contains informative examples that help explain the procedures for calculating the IEER as defined in Section 11 for VRF Systems having a single or multiple compressor(s) with fixed or variable speed indoor fan(s). This appendix is not intended to replace the prescriptive requirements in Section 11 but is intended to help in the application of the IEER to different products covered by this standard.

G2.1 *Example 1 – Air-source Unit with a Single Variable Speed Compressor and a Variable Speed Fan IEER Example Calculations.*

The unit is an Air-source unit with a single Variable Speed Compressor and a variable speed fan that is configured as a unit where the thermostat controls the airflow, and the capacity is controlled to a leaving air temperature. The unit has the following rated performance metrics:

- Rated Capacity = 118,000 Btu/h
- Rated Standard Airflow = 3,400 scfm
- Rated EER = 11.2 (Btu/h)/W
- Rated IEER = 12.0 (Btu/h)/W

Shown in Table G1a are the test data. During the tests the atmospheric pressure is measured at 14.70 psia, is constant for all tests, and above the minimum allowable atmospheric pressure of 13.700 psia. The pressure can vary between tests; therefore, the pressure should be measured for each test.

Table G1a. Example 1: Test Results											
Test	Stage	Test OAT, °F	Req OAT, °F	Actual Percent Load, %	Test Net Capacity, Btu/h	Test CFM (Std Air), cfm	Compressor (P _C) (Test), W	Condenser (P _{CD}) (Test), W	Indoor (P _{IF}) (Test), W	Control (P _{CT}) (Test), W	EER (Test), (Btu/h)/W
1	100%	95.1	95.0	100.0	117,455	3345	8450	650	1150	125	11.32
2	75%	81.3	81.5	75.4	88,599	2550	5408	650	519	125	13.22
3	50%	68.7	68.0	50.9	59,765	1720	3725	650	166	125	12.81
4	25%	65.3	65.0	29.7	34,863	990	1727	325	33	125	15.77

A total of four tests are run to use in the calculation of the EER rating points EER_{A, Full}, EER_B, EER_C, and EER_D and the calculation of the IEER. Test 1 is the full load rating point. Test 2 is targeted to run at the 75% Load rating point and the

measured test Percent Load is 75.4%, within the 3% tolerances. Therefore, additional testing is not required. For the 50% Load rating point, Test 3 is run to get the 50% Load rating and the test measured Percent Load is 50.9%, within the allowable tolerance of 3%. Test 4 is run at the 65°F ambient for the rating point EER_D, but, even after Critical Parameter adjustments as described in Section 6.3.3, the unit could only unload to 29.7% Load. This test requires that a degradation calculation be performed.

As defined in Section 11, the procedure can be performed to calculate the EER_{A, Full}, EER_B, EER_C and EER_D point ratings using the test results. Shown in Table G1b are the calculations for the four EER rating points used to calculate the IEER.

Table G1b. Example 1: IEER Rating Points and Degradation Calculations

Rating Point	Test	Test OAT, °F	Req OAT, °F	Actual Percent Load, %	Net Capacity (Test), Btu/h	Compressor (P _C) (Test), W	Condenser (P _{CD}) (Test), W	Indoor (P _{IF}) (Test), W	Control (P _{CT}) (Test), W	EER (Test), (Btu/h)/W	LF	CD	Rating EER
A	1	95.1	95.0	100.0	117,455	8450	650	1150	125	11.32			
	required load			100.0	use test 1 point directly							—	—
B	2	81.3	81.5	75.4	88,599	5408	650	650	125	13.22			
	required load			75%	use test 2 point directly							—	—
C	3	68.7	68.0	50.9	59,765	3725	650	650	125	12.81			
	required load			50.0	use test 3 point directly								
D	4	65.3	65.0	29.7	34,863	1727	325	33	125	15.77			
	Required Load			25.0	degradation of test 4 required							0.842	1.021

For rating point A, the 100% Load rating point, Test 1 can be used directly. For the 75% Load rating point EER_B, the test load is 75.4% Load, within the 3% tolerance. This test point can be used directly for the rating point EER_B, and degradation is required. For the 50% Load rating point EER_C, Test 3 is run to get the 50% Load rating and the test Percent Load is 50.9%, within the 3% tolerance. Test 3 can be used directly for the point EER_C EER determination. For the rating point EER_D, Test 4 is run but due to control limits the unit only unloaded to 29.7% Load, greater than the 25% Load target with a 3% tolerance (25%+3%=28%). Therefore, degradation calculation is required as follows.

The degradation factor calculations are performed using the requirements of Section 11.

First the load factor (LF) is calculated using Equation 12:

$$LF = \frac{\left(\frac{P_L}{100}\right) \cdot q_{Full}}{q_{PL}} = \frac{\left(\frac{25}{100}\right) \cdot 117,445}{34,863} = 0.842$$

This result shows that at a 25% load, the compressor is on for 84.2% of the time and off for 15.8% of the time.

C_D is then calculated using Equation 11:

$$C_D = (-0.13 \cdot LF) + 1.13 = (-0.13 \cdot 0.842) + 1.13 = 1.021$$

Once the degradation factor is calculated, the rating point EER is calculated using Equation 10 for the rating point EER_D:

$$EER = \frac{LF \cdot Q}{LF \cdot [C_D \cdot (P_C + P_{CD})] + P_{IF} + P_{CT}} = \frac{0.842 \cdot 34,863}{0.842 \cdot [1.021 \cdot (1,727 + 325)] + 33 + 125} = 15.27 \text{ (Btu/h)/W}$$

Calculate the IEER using Equation 9:

$$IEER = (0.020 \cdot EER_A) + (0.617 \cdot EER_B) + (0.238 \cdot EER_C) + (0.125 \cdot EER_D)$$

$$= (0.02 \cdot 11.32) + (0.617 \cdot 13.22) + (0.238 \cdot 12.81) + (0.125 \cdot 15.27) = 13.34 \text{ (Btu/h)/W}$$

G2.2 Example 2. Air-source Unit with Two Compressor with One Being Fixed Speed and the Other Being Variable Speed Compressor and a Variable Speed Indoor Fan IEER Example Calculations.

The unit is an Air-source unit with two compressors in the same refrigeration circuit, with the first being a Variable Capacity compressor and the other being a fixed capacity compressor. The indoor fan is a variable speed. The unit has the following rated performance metrics:

- Rated Capacity = 118,000 Btu/h
- Rated Standard Airflow = 3,400 scfm
- Rated EER = 11.2 (Btu/h)/W
- Rated IEER = 13.0 (Btu/h)/W

Shown in Table G2a are the test data. During the tests the atmospheric pressure is measured at 14.70 psia, is constant for all tests, and above the minimum allowable atmospheric pressure of 13.700 psia. The pressure can vary between tests; therefore, the pressure should be measured for each test.

Test	Stage	Test OAT, °F	Req OAT, °F	Actual Percent Load, %	Test Net Capacity, Btu/h	Test CFM (Std Air), cfm	Compressor (P _C) (Test), W	Condenser (P _{CD}) (Test), W	Indoor (P _{IF}) (Test), W	Control (P _{CT}) (Test), W	EER (Test), (Btu/h)/W
1	1@100% 2@100%	95.1	95.0	100.0	119,500	3300	8725	650	1100	125	11.27
2	1@ 48% 2@100%	81.3	81.5	75.1	89,788	2550	5584	650	521	125	13.05
3	1@98% 2@ off	68.7	68.0	50.7	60,563	1720	3846	650	166	150	12.59
4	1@ 46% 2@off	65.3	65.0	24.4	29,197	990	1427	325	33	150	15.09

A total of four tests are run to use in the calculation of the EER rating points EER_{A, Full}, EER_B, EER_C, and EER_D and the calculation of the IEER. Test 1 is the full load rating point. Test 2 is targeted to run at the 75% load rating point and as you can see the measured percent load is 75.1% so this value is within the 3% tolerances and additional testing is not required. For this test, one compressor is on, and the Variable Speed Compressor is at 48% Load capacity. For the 50% Load rating point, test 3 is run to get the 50% rating and the test measured load is 50.7% and is within the allowable tolerance of 3%. For this test 1 compressor is turned off and the Variable Speed Compressor is run at 98% Load capacity. Test 4 is run at the 65 °F ambient for the rating point EER_D and the measured Percent Load is 24.4% so it can be used directly for the EER determination. Because all the tests are be run at the required load, additional degradation is not required.

Using Section 11, procedure calculations are performed to determine the ratings at the EER_{A, Full}, EER_B, EER_C and EER_D IEER points. Shown in Table G2b are the calculations for the four EER rating points used to calculate the IEER.

Table G2b. Example 2: IEER Rating Points and Degradation Calculations

Rating Point	Test	Test OAT, °F	Req OAT, °F	Actual Percent Load, %	Net Capacity (Test), Btu/h	Compressor (P _C) (Test), W	Condenser (P _{CD}) (Test), W	Indoor (P _{IF}) (Test), W	Control (P _{CT}) (Test), W	EER (Corr), (Btu/h)/W	LF	CD	Rating EER	
A	1	95.1	95.0	100.0	119,500	8725	650	1100	125	11.27				
	required load			100.0	use test 1 point directly								—	—
B	2	81.3	81.5	75.5	89,788	5584	650	521	125	13.05				
	required load			75.0	use test 2 point directly								—	—
C	4	68.4	68.0	43.0	60,563	3846	650	166	150	12.59				
	required load			50.0	use test 3 point directly								—	—
D	5	65.3	65.0	24.4	29,197	1427	325	33	150	15.09				
	Required load			25.0	use test 4 point directly								—	—

Because the four tests can be run at the required load within the tolerance, additional calculations are not required and the test EER can be used directly for the IEER calculations.

Calculate the IEER using Equation 9:

$$IEER = (0.020 \cdot EER_{A,Full}) + (0.617 \cdot EER_B) + (0.238 \cdot EER_C) + (0.125 \cdot EER_D)$$

$$= (0.02 \cdot 11.27) + (0.617 \cdot 13.05) + (0.238 \cdot 12.59) + (0.125 \cdot 15.09) = 13.16 \text{ (Btu/h)/W}$$

G3 *Example Calculations for Systems that do not Meet Capacity Thresholds with STI-specified Critical Parameter adjustments.* This Appendix contains informative example calculations for Critical Parameter adjustments within the tolerance budget and for calculating IEER as defined in Section 11 for VRF systems that do not meet the capacity requirement outlined in Section 6.3.3.

G3.1 *Example 3. A unit where the capacity exceeds the maximum threshold of 3% of the target load fraction for the 75% and 25% tests.*

A series of CVP tests are performed on a unit with a single compressor, fan, and Outdoor Unit where the capacity exceeds the maximum threshold of 3% of the target load fraction for the 75% and 25% tests. Assume the following rated performance metrics.

- Rated Capacity = 100,000 Btu/h
- Rated Standard Airflow = 2,200 scfm
- Rated EER = 11.2 (Btu/h)/W
- Rated IEER = 12.0 (Btu/h)/W

The STI-reported critical parameter values are shown in Table G3a. A 100% CVP test is not conducted for this unit, and therefore the STI-reported values at 100% are used to calculate the Parameter Percent Difference.

Table G3a. STI-reported Critical Parameter Values						
Critical Parameters			Test Load Point			
Group	Unique ID	Measurement Units	100%	75%	50%	25%
Compressor	Comp_1	Hz	100	76	50	28
Outdoor Fan	ODF_1	RPS	1000	780	550	290
Modulating Valve	MV_1	Pulses	100	82	58	28

Shown in Table G3b are the test data. During the tests the atmospheric pressure is measured at 13.90 psia and is constant for all tests, that is above the minimum allowable atmospheric pressure of 13.700 psia. The pressure can vary between tests; therefore, the pressure is measured for each test

Four tests are run to use in the calculation of the EER rating points EER_{A, Full}, EER_B, EER_C, and EER_D and the calculation of the IEER; results are shown in Table G3b. Test 1 is the full load rating point, and the measured capacity is 2% greater than the Rated Capacity, falling within the 3% tolerance. Test 2 is targeted to run at the 75% part-load rating point and the measured

percent load is 81% exceeding the 3% tolerance. For the 50% Load rating point, test 3 is run to get the 50% rating and the test measured load is 49.1% within the allowable tolerance of 3%; and therefore, additional testing is not required. Test 4 is run at the 65°F ambient for the rating point EER_D and the measured Percent Load is 40%, exceeding the 3% threshold.

Table G3b. Example 3: Initial Test Results

Test	Compressor Speed	Test OAT, °F	Req OAT, °F	Actual Percent Load, %	Test Power Consumption, W	Test Net Sensible Capacity, Btu/h	Test Net Total Capacity, Btu/h	SHR	SHR Limit	EER (Test), (Btu/h)/W
1	100 Hz	94.7	95.0	102	10,160	99,708	123,096	0.81	0.82	12.11
2	76 Hz	81.7	81.5	81	7230	77,122	95,212	0.83	0.85	13.17
3	50 Hz	67.8	68.0	49.1	4562	59,957	60,563	0.99	—	13.28
4	28 Hz	65.6	65.0	40	1861	28,321	29,197	0.97	—	18.70

The STI specifies to decrease the compressor speed when the capacity is above 3% of the target load fraction for a given part-load test (75, 50, or 25% load) or the given Rated Capacity for a given 100% test. In a second series of tests at the 100% and 25% load points, the lab overrides the compressor speed, gradually decreasing the value. The speed is decreased from 76 Hz to 73 Hz at the 100% load point, and from 28 Hz to 22.7 Hz at the 25% load point. As a result of the compressor speed adjustment, the SHR values increased to within the allowable range. The data is outlined in Table G3c.

Table G3c. Example 3. Test Results with Compressor Speed Adjustments

Test	Stage	Test OAT, °F	Req OAT, °F	Actual Percent Load, %	Test Power Consumption, W	Test Net Sensible Capacity, Btu/h	Test Net Total Capacity, Btu/h	SHR	SHR Limit	EER (Test), (Btu/h)/W
1	100 Hz	95.1	95.0	102	10,160	99,708	121,595	0.82	0.82	11.97
2	73 Hz	81.3	81.5	78	7592	77,122	90,731	0.85	0.85	11.95
3	50 Hz	68.7	68.0	49.1	4562	59,957	60,563	0.99	—	13.28
4	22.7 Hz	65.3	65.0	34.7	1959	31,355	32,672	0.99	—	16.68

Because the compressor speed is overridden, the adjusted Critical Parameter values must meet the tolerance budget outlined in Section C6.2. Using Equation C4, the lab calculates the Nominal Point Value for the compressor speed adjustment for the 75% and 25% tests.

75%: $3\% * 13 \text{ points} = 39 \text{ points}$

25%: $5.3\% * 13 \text{ points} = 68.9 \text{ points}$

The RSS Point Totals for the 75% and 25% tests are calculated using Equation C5:

75%: $RSS \text{ Point Total} = \sqrt{39^2 + 0^2 + 0^2} = 39 \text{ points}$

25%: $RSS \text{ Point Total} = \sqrt{68.9^2 + 0^2 + 0^2} = 68.9 \text{ points}$

Because the RSS point total for the 75% test is less than the overall budget is less than 70 points, and the SHR is below the allowable limit, the test is validated. However, the budget is exhausted in the 25% test before the capacity fell within the 3% part-load tolerance. To further adjust the capacity, a degradation calculation is performed as follows:

The degradation factor calculations are performed using the requirements of Section 11.

First, the load factor (LF) is calculated using Equation 12:

$$LF = \frac{\left(\frac{P_L}{100}\right) \cdot q_{Full}}{q_{PL}} = \frac{\left(\frac{25}{100}\right) \cdot 121,595}{32,672} = 0.930$$

The result shows that at a 25% load, the compressor is on for 93% of the time and off for 7% of the time.

C_D is then calculated using Equation 11:

$$C_D = (-0.13 \cdot LF) + 1.13 = (-0.13 \cdot 0.930) + 1.13 = 1.009$$

Once the degradation factor is calculated, the rating point EER is calculated using Equation 10 for the rating point EER_D . The compressor, condenser, indoor, and control power from the adjusted test are presented in Table G3d.

Compressor (P_C) (Test), W	Condenser (P_{CD}) (Test), W	Indoor (P_{IF}) (Test), W	Control (P_{CT}) (Test), W
8450	650	1150	125
5408	650	519	125
3725	650	166	125
1727	325	33	125

$$EER = \frac{LF \cdot Q}{LF \cdot [C_D \cdot (P_C + P_{CD})] + P_{IF} + P_{CT}} = \frac{0.930 \cdot 32,672}{0.930 \cdot [1.009 \cdot (1,727 + 325)] + 33 + 125} = 14.58 \text{ (Btu/h)/W}$$

Calculate the IEER using Equation 9:

$$IEER = (0.020 \cdot EER_A) + (0.617 \cdot EER_B) + (0.238 \cdot EER_C) + (0.125 \cdot EER_D)$$

$$IEER = (0.020 \cdot 11.97) + (0.617 \cdot 11.95) + (0.238 \cdot 13.28) + (0.125 \cdot 14.58) = 12.59 \text{ (Btu/h)/W}$$

G4 Example Calculations for Adjusting IEER for Systems that Do Not Meet the Sensible Heat Ratio (SHR) Requirement. This Appendix contains informative examples for calculating IEER as defined in Section 11 for VRF systems that do not meet the SHR requirement outlined in Section 6.3.3.

G4.1 Example 5. A unit where the Sensible Heat Ratio exceeds the allowable limit at 100% load and 75% part-load test points, and the lab has maximized the allowable compressor speed adjustments.

A series of CVP tests are performed on a unit with a single compressor, fan, and Outdoor Unit, where the Sensible Heat Ratio exceeds the allowable limit at 100% load and 75% part-load test points, and the lab has maximized the allowable compressor speed adjustments. Assume the following rated performance metrics:

- Rated Capacity = 120,000 Btu/h
- Rated Standard Airflow = 2,200 scfm
- Rated EER = 11.2 (Btu/h)/W
- Rated IEER = 12.0 (Btu/h)/W

The STI-reported critical parameter values are shown in table G4a. A 100% CVP test is not conducted for this unit; therefore the STI-reported values at 100% are used to calculate the Parameter Percent Difference.

Critical Parameters			Test Load Point			
Group	Unique ID	Measurement Units	100%	75%	50%	25%
Compressor	Comp 1	Hz	100	76	50	28
Outdoor Fan	ODF 1	RPS	1000	780	550	290
Modulating Valve	MV 1	Pulses	100	82	58	28

Shown in Table G4b are the test data. During the tests the atmospheric pressure is measured at 13.90 psia, is constant for all tests, and above the minimum allowable atmospheric pressure of 13.700 psia. The pressure can vary between tests; therefore, the pressure is measured for each test.

Test	Stage	Test OAT, °F	Req OAT, °F	Actual Percent Load, %	Test Power Consumption, W	Test Net Sensible Capacity, Btu/h	Test Net Total Capacity, Btu/h	SHR	SHR Limit	EER (Test), (Btu/h)/W
1	100 Hz	95.1	95.0	100.0	10,603	101,600	118,139	0.86	0.82	11.14
2	76 Hz	81.3	81.5	75.1	6880	78,115	89,769	0.89	0.85	13.05
3	50 Hz	68.7	68.0	50.7	4732	59,345	60,563	0.98	—	12.59
4	28 Hz	65.3	65.0	24.4	1935	29,197	29,197	1.00	—	15.09

A total of four tests are run to use in the calculation of the EER rating points $EER_{A, Full}$, EER_B , EER_C , and EER_D and the calculation of the IEER. Test 1 is the full load rating point. Test 2 is targeted to run at the 75% part-load rating point and the measured percent load is 75.1%, within the 3% tolerance and additional testing is not required. For the 50% Load rating point, test 3 is run to get the 50% rating and the test measured load is 50.7%, within the allowable tolerance of 3%. Test 4 is run at the 65 °F ambient for the rating point EER_D and the measured Percent Load is 24.4% and can be used directly for the EER determination. Because Test 2, Test 3, and Test 4 are run at the required load, additional degradation is not required.

In this example, both Test 1 and Test 2 produced Sensible Heat Ratios above the allowable limits and the lab increased the compressor speed to the point that the capacity reached the maximum threshold of 3% above the target load fraction for the 75% test and 3% above the Rated Capacity for the 100% test. The adjusted test results resulting from increasing compressor speed are represented in Table G4c.

Test	Stage	Test OAT, °F	Req OAT, °F	Actual Percent Load, %	Test Power Consumption, W	Test Net Sensible Capacity, Btu/h	Test Net Total Capacity, Btu/h	SHR	SHR Limit	EER (Test), (Btu/h)/W
1	103 Hz	95.1	95.0	103.0	10,921	101,600	120,952	0.84	0.82	11.08
2	78.9 Hz	81.3	81.5	78.0	7086	78,115	89,788	0.87	0.85	12.67
3	50 Hz	68.7	68.0	50.7	4732	59,345	60,563	0.98	—	12.59
4	28 Hz	65.3	65.0	24.4	1935	29,197	29,197	1.00	—	15.09

Because the SHR remains above the allowable limits in both the 100% and 75% tests, the methods described in Section 11.2.2.3 are used to adjust sensible capacity until the adjusted SHR is equal to the SHR limit. The calculations for the 4 EER rating points are shown in Table G3b. For rating points $EER_{A, Full}$ and EER_B , the sensible capacity is adjusted until the SHR target is achieved, using Equation 13:

Rating Point A:

$$q_{Sens,Adj} = q_{Latent} * \frac{SHR_{Req}}{1 - SHR_{Req}} = 19,352 * \frac{0.82}{1 - 0.82} = 88,159$$

Rating Point B:

$$q_{Sens,Adj} = q_{Latent} * \frac{SHR_{Req}}{1 - SHR_{Req}} = 11,673 * \frac{0.85}{1 - 0.85} = 66,147$$

Then, the rating EER is adjusted based on the new total capacity, using Equation 14:

Rating Point A:

$$EER_{Adj} = \frac{q_{Sens,Adj} + q_{latent}}{\dot{E}_{tot}} = \frac{88,159 + 19,352}{10,921} = 9.84$$

Rating Point B:

$$EER_{Adj} = \frac{q_{Sens,Adj} + q_{latent}}{\dot{E}_{tot}} = \frac{66,147 + 11,673}{7,086} = 10.98$$

Calculate the IEER using Equation 9:

$$IEER = (0.020 \cdot EER_{A,Full}) + (0.617 \cdot EER_B) + (0.238 \cdot EER_C) + (0.125 \cdot EER_D)$$

$$IEER = (0.020 \cdot 9.84) + (0.617 \cdot 10.98) + (0.238 \cdot 12.59) + (0.125 \cdot 15.09) = 11.85 \text{ (Btu/h)/W}$$

APPENDIX H. EXAMPLE CALCULATIONS FOR CRITICAL PARAMETER BUDGET METHOD – INFORMATIVE

A series of CVP tests are conducted on a unit with two compressors, two fans, and two outdoor variable valves with a 100% cooling capacity of 100,000 Btu/h. The STI indicates that the three critical parameters of the compressor speed, fan speed, and LEV position are overridden. The STI-reported critical parameter values are presented in Table H1.

Table H1. STI-reported Critical Parameter Values						
Critical Parameters			Test Load Point			
Group	Unique ID	Measurement Units	100%	75%	50%	25%
Compressor	Comp_1	Hz	100	76	50	28
Compressor	Comp_2	Hz	110	70	64	20
Outdoor Fan	ODF_1	RPS	1000	780	550	290
Outdoor Fan	ODF_2	RPS	1500	750	480	250
Modulating Valve	MV_1	Pulses	122	102	58	28
Modulating Valve	MV_2	Pulses	130	106	66	26

When these values are used to determine variance, the values for each critical parameter group are averaged for each load point. During the CVP, critical parameter values are continuously recorded. For each parameter reading, the two values from each critical parameter group are averaged and used to calculate the variance, using Equation C3, as follows for the compressor speed.

$$\frac{|78 - 73|}{105} * 100 = 4.8 \%$$

This calculation process is outlined in Table H2 for the system at 75% capacity.

Table H2. 75% Instantaneous Parameter Variation Calculation										
—	STI-Reported Value #1	STI-Reported Value #2	Average STI Value	Measured Value #1	Measured Value #2	Average Measured Value	100% Max Value #1	100% Max Value #2	Average 100% Max Value	Percent Variation (%)
Compressor	76	70	73	82	74	78	100	110	105	4.8
Fan	780	750	765	756	730	743	1000	1500	1250	1.8
LEV	102	106	104	95	85	90	100	104	102	13.7

This variance is used to calculate the points accrued by each parameter (Equation C4). To validate the parameters used in this 75% steady state test, each parameter’s points are combined using Equation C5. These calculations are presented in Table H3.

Table H3. Instantaneous Parameter Point Calculation			
—	Percent Variation (%)	Nominal Point Value	Points Accrued ¹
Compressor	4.8	13	62.4
Fan	1.8	7	12.6
LEV	13.7	1	13.7
—	—	RSS Point Total	65.12
Note			
1. In accordance with Equation C5			

These calculations are performed for each measurement throughout the CVP, along with a rolling average of the RSS Point Total. If at least one measurement period of at least three minutes and a minimum of five sample readings occurs where the average RSS Point Total is ≤ 70 points, the critical parameters in the STI at the 75% load point are validated. This process is presented in Table H4.

Table H4. Measurement Period Point Total Average

Measurement #1	Measurement #2	Measurement #3	Measurement #4	Measurement #5	Average Point Total
74.87	67.87	68.62	70.44	61.23	68.61

Because the average point total is less than 70, the critical parameters for this test are validated, despite the two measurements during the period that exceed the budget.