

AHRI Standard 1360-2022 (I-P)

**2022 Standard for
Performance Rating of
Computer and Data
Processing Room
Air Conditioners**



we make life better®

2311 Wilson Boulevard, Suite 400
Arlington, VA 22201, USA
www.ahrinet.org
PH 703.524.8800
FX 703.562.1942



©Copyright 2022, by Air-Conditioning, Heating, and Refrigeration Institute
Registered United States Patent and Trademark Office
Printed in U.S.A.

**IMPORTANT
SAFETY DISCLAIMER**

AHRI does not set safety standards and does not certify or guarantee the safety of any products, components or systems designed, tested, rated, installed or operated in accordance with this standard/guideline. It is strongly recommended that products be designed, constructed, assembled, installed and operated in accordance with nationally recognized safety standards and code requirements appropriate for products covered by this standard/guideline.

AHRI uses its best efforts to develop standards/guidelines employing state-of-the-art and accepted industry practices. AHRI does not certify or guarantee that any tests conducted under its standards/guidelines will be non-hazardous or free from risk.

ICS Code: 23.120

Note:

This standard supersedes AHRI Standard 1360-2017 (I-P).

For SI ratings, see AHRI Standard 1361-2022 (SI).

AHRI CERTIFICATION PROGRAM DISCLAIMER

AHRI Standards are developed independently of AHRI Certification activities and can have scopes that include products that are not part of the AHRI Certification Program. The scope of the applicable AHRI Certification Program can be found on AHRI's website at <http://www.ahrinet.org>.

Intent

This standard is intended for the guidance of the industry, including manufacturers, engineers, installers, contractors, users, and regulators.

Review and Amendment

This standard is subject to review and amendment as technology advances.

2022 Edition

This edition of AHRI Standard 1360 (I-P), *Performance Rating of Computer and Data Processing Room Air Conditioners*, was prepared by Datacom Standards Technical Committee. The standard was approved by the Applied Standards Subcommittee in November 2022.

Origin and Development of AHRI Standard 1360 (I-P)

The initial publication was ANSI/AHRI Standard 1360-2013, *Performance Rating of Computer and Data Processing Room Air Conditioners*. Subsequent revisions were:

ANSI/AHRI Standard 1360 (I-P) (with Addendum 1), *Performance Rating of Computer and Data Processing Room Air Conditioners*

ANSI/AHRI Standard 1360 (I-P)-2016, *Performance Rating of Computer and Data Processing Room Air Conditioners*

AHRI Standard 1360-2017 (I-P), *Performance Rating of Computer and Data Processing Room Air Conditioners*

Summary of Changes

AHRI Standard 1360-2022 (I-P) contains the following updates to the previous edition:

- Added roof-mounted and wall-mounted units
- Modified ESP calculations for reduced height test chambers
- Added test requirements that are currently unreleased items in ASHRAE 37 and ASHRAE 127

Committee Personnel
Datacom Standards Technical Committee

Participant	Interest Category Classification	Voting Member Role	State / Province / Country
Dave Kelley Vertiv Corporation	Product Manufacturer	Chair	OH, USA
Mohammad Abbadi Zamil Air Conditioners & Home Appliances	Product Manufacturer	Primary	Saudi Arabia
Samir Hamed Petra Engineering Industries Co.	Product Manufacturer	Primary	Jordan
Byron Horak Intertek	Testing Laboratory	Primary	NY, USA
David McGlocklin Schneider Electric IT Corporation	Product Manufacturer	Primary	MO, USA
Aniruddh Roy Energy Solutions	General	Primary	CA, USA
Jake Yu AIRSYS Refrigeration Engineering	Product Manufacturer	Primary	CA, USA
Mohammed Abu-Baha' Petra Engineering Industries Co.	Product Manufacturer	Alternate to Samir Hamed	Jordan
Anthony Cacciotti Intertek	Testing Laboratory	Alternate to Byron Horak	NY, USA
Ben Dolcich Vertiv Corporation	Product Manufacturer	Alternate to Dave Kelley	OH, USA
Leo Long Schneider Electric IT Corporation	Product Manufacturer	Alternate to David McGlocklin	MO, USA
Lisa Saponaro Vertiv Corporation	Product Manufacturer	Alternate to Dave Kelley	OH, USA
Jerry Yeh	AHRI Staff Liaison		

Datacom Standards Technical Committee Scope:

The Datacom equipment (DCOM) Standards Technical Committee is responsible for the development and maintenance of AHRI standards and guidelines pertaining to Performance Rating of Computer and Data Processing Room Air Conditioners.

Out of scope for this STC include Chillers, Energy Recovery Ventilator (ERV), Variable Frequency Drives (VFD), Humidifiers, Air Distribution, Chilled Beam, Unit Ventilator, Room Fan Coils, Heat Exchange, Air Handling, Air Filters, Dehumidifiers, Air Cooling and Air Heating Coils (ACAH), and Thermal Storage Equipment not marketed for application in information technology equipment facilities.

Product definitions are as defined within AHRI 1360.

Applied Standards Subcommittee

Participant	Interest Category Classification	Voting Member Role	State / Province / Country
Patrick Marks Johnson Controls, Inc.	Product Manufacturer	Chair	PA, USA
Darcy Lee Trane U.S. Inc.	Product Manufacturer	Vice Chair	GA, USA
Brandon Bates Energistics Laboratory	Testing Laboratory	Primary	TX, USA
Craig Burg Engineering, Desert Aire Corp.	Product Manufacturer	Primary	WI, USA
Jennifer Butsch Emerson Commercial and Residential Solutions	Product Manufacturer	Primary	OH, USA
Jeff deRoos Carrier Corporation	Product Manufacturer	Primary	FL, USA
Henry Ernst Daikin Applied Americas Inc.	Product Manufacturer	Primary	MN, USA
Dana Fischer Mitsubishi Electric Cooling & Heating	Product Manufacturer	Primary	GA, USA
Armin Hauer ebm-papst Inc.	Product Manufacturer	Primary	CT, USA
Tom McDermott Swegon North America Inc.	Product Manufacturer	Primary	ON, Canada
Eric Sakal GE Appliances, a Haier Company	Product Manufacturer	Primary	KY, USA
Karl Best	AHRI Staff Liaison		

Applied Standards Subcommittee Scope:

The scope of the Applied Standards Subcommittee is standards and guidelines related to the end products that are part of the AHRI Applied Industry Sector. (The definition of and list of products associated with each sector are found on the AHRI website.

This list represents the membership at the time the Standards Technical Committee and Standards Subcommittee were balloted on the final text of this edition. Since that time, changes in the membership may have occurred. Membership on these committees shall not in and of itself constitute an endorsement by the committee members or their employers of any document developed by the committee on which the member serves.

TABLE OF CONTENTS

SECTION	PAGE
Section 1. Purpose	1
Section 2. Scope	1
Section 3. Definitions	1
Section 4. Classifications	6
Section 5. Test Requirements	8
Section 6. Rating Requirements	11
Section 7. Minimum Data Requirements for Published Ratings	16
Section 8. Operating Requirements	18
Section 9. Marking and Nameplate Data	18
Section 10. Conformance Conditions	18

TABLES

Table 1. Classification of Computer and Data Processing Room Air Conditioners	7
Table 2. Tolerances for Charging Hierarchy	10
Table 3. Indoor Return Air Temperatures Standard Rating Conditions.....	12
Table 4. Heat Rejection / Cooling Fluid Standard Rating Conditions	12
Table 5. Minimum External Static Pressure Standard Requirements	13
Table 6. Outdoor Air ESP Requirements for Units with Ducted Condensers.....	13
Table 7. Tolerances.....	15
Table 8. Uncertainty Allowances.....	16
Table 9. Published Ratings	17

APPENDICES

Appendix A.	References – Normative.....	19
Appendix B.	References – Informative.....	20
Appendix C.	Standard Configurations - Normative.....	21
Appendix D.	Unit Configuration for Standard Efficiency Determination - Normative	26
Appendix E.	Method of Testing Computer and Data Processing Room Air-conditioners - Normative	32
Appendix F.	Indoor and Outdoor Air Condition Measurement - Normative.....	42
Appendix G.	Integrated Net Sensible COP Rating- Informative.....	51
Appendix H.	Example of Determination of Fan and Motor Efficiency for Non-standard Integrated Indoor Fan and Motors – Informative	53

TABLES FOR APPENDICES

Table C1.	Ceiling-mounted Standard Configuration Airflows	22
Table C2.	Floor-mounted Standard Configuration Airflows	24
Table C3.	Wall-mounted Standard Configurations	25
Table C4.	Roof-mounted Standard Configurations	25
Table D1.	Test Procedures and Reference Motor Efficiency	28
Table D2.	BLDC Motor and ECM – Fractional hp – Reference Efficiencies	29
Table D3.	Values for Evaluating the Fan Input Power for Non-standard Fans	30
Table E1.	ESP Adjustment.....	33
Table F1.	Temperature Measurement Requirements	42
Table F2.	Uniformity Criteria for Outdoor Air Temperature and Humidity Distribution	49
Table G1.	Cooling Fluid Standard and Reduced Ambient Rating Conditions	52

FIGURES FOR APPENDICES

Figure C1.	Ceiling-mounted Unit–ducted.....	21
Figure C2.	Ceiling-mounted Unit–nonducted.....	21
Figure C3.	Downflow unit.....	22
Figure C4.	Horizontal-flow Unit	23
Figure C5.	Upflow Unit–ducted or Upflow Unit–nonducted	23
Figure C6.	Wall-mounted Unit.....	24
Figure C7.	Roof-mounted Unit.....	25

Figure E1.	Test Duct Setup for Upflow Unit with Single Fan Outlet Connection in Limited Height Test Chamber.....	34
Figure E2.	Test Duct Setup for Up-flow Unit with Multiple Fan Outlet Connections in Limited Height Test Chamber.....	35
Figure E3.	Example Test Setup for Outlet Plenum for Free Air Discharge Units.....	40
Figure F1.	Aspirating Psychrometer.....	43
Figure F2.	Example Air Sampling Tree	44
Figure F3.	Determination of Measurement Rectangles and Required Number of Air Sampling Trees	45
Figure F4.	Example Test Setup Configurations	46
Figure H1.	Illustration of The Duty Point Where Standard and Non-standard Fan Input Power is Compared	53

PERFORMANCE RATING OF COMPUTER AND DATA PROCESSING ROOM AIR CONDITIONERS

Section 1. Purpose

The purpose of this standard is to establish definitions, classification, test requirements, rating requirements, minimum data requirements for Published Ratings, marking and nameplate data, and conformance conditions for Computer and Data Processing Room Air Conditioners (CDPR).

Section 2. Scope

This standard applies to CDPRs specifically marketed for cooling Data Centers and Information Technology Equipment (ITE) and as defined in Section 3. This standard does not apply to the rating and testing of individual assemblies, such as condensing units or coils, for separate use.

Section 3. Definitions

All terms in this document will follow the standard industry definitions in the ASHRAE Terminology website unless otherwise defined in this section.

3.1 *Expressions of Provision.* Terms that provide clear distinctions between requirements, recommendations, permissions, options, and capabilities.

3.1.1 “*Can*” or “*cannot*”. Express an option or capability.

3.1.2 “*May*”. Signifies a permission expressed by the document.

3.1.3 “*Must*”. Indication of unavoidable situations and does not mean that an external constraint referred to is a requirement of the document.

3.1.4 “*Shall*” or “*shall not*”. Indication of mandatory requirements to strictly conform to the standard and where deviation is not permitted.

3.1.5 “*Should*” or “*should not*”. Indication of recommendations rather than requirements. In the negative form, a recommendation is the expression of potential choices or courses of action that is not preferred but not prohibited.

3.2 *Standard Specific Definitions*

3.2.1 *Air Economizer.* An automatic system that enables a cooling system to supply and use outdoor air to reduce or eliminate the need for mechanical cooling during mild or cold weather. Provides energy efficiency improvements on an annualized basis and is a function of regional ambient conditions and is not part of the NSenCOP metric.

3.2.2 *Air Sampling Device(s).* A combination of Air Sampling Tree(s), conduit, fan and Aspirating Psychrometer or Dew-point Hygrometer used to determine dry-bulb temperature and moisture content of an air sample from critical locations.

3.2.2.1 *Air Sampling Tree.* An assembly consisting of a manifold with branch tubes with multiple sampling holes that draws an air sample from a critical location from the unit under test (such as an indoor air inlet, indoor air outlet, or outdoor air inlet).

3.2.2.2 *Aspirating Psychrometer.* An instrument used to determine the humidity of air by simultaneously measuring both the wet-bulb and dry-bulb temperatures. The difference between these temperatures is referred to as the wet-bulb depression.

AHRI STANDARD 1360-2022 (I-P)

3.2.2.3 *Dew-point Hygrometer.* An instrument used to determine the humidity of air by detecting visible condensation of moisture on a cooled surface.

3.2.3 *Application Configurations.* Unit configurations other than Standard Configurations.

3.2.4 *Ceiling-mounted Unit.* A type of CDPR with an Indoor Unit marketed to be installed above a dropped ceiling inside a building with one airflow direction through the unit (horizontal) and multiple airflow connections. Discharge from the unit consists of either Ducted Discharge or Free Air Discharge. Return to the unit consists of either Ducted Return or Free Air Return.

3.2.5 *Coils.*

3.2.5.1 *Chilled Water Dual Cooling Coil.* A secondary chilled water coil added in the indoor air stream of a CPDR for use as the primary or secondary cooling circuit in conjunction with a separate chiller.

3.2.5.2 *Coated Coils.* An indoor coil or outdoor coil whose entire surface, including the entire surface of both fins and tubes, is covered with a thin continuous non-porous coating to reduce corrosion.

3.2.5.3 *Hydronic Heat Coils (Steam or Hot Water).* Heat exchanger coils and controls that are located downstream of the cooling coil that can heat the air using building steam or hot water during the dehumidification process.

3.2.5.4 *Refrigerant Reheat Coils.* A heat exchanger located downstream of the indoor coil that heats the Supply Air during cooling operation using high pressure refrigerant to increase the ratio of moisture removal to Cooling Capacity provided by the equipment.

3.2.6 *Compressor Variable Frequency Drive (VFD).* A device connected electrically between the equipment's power supply connection and the compressor that can vary the frequency of power supplied to the compressor to allow variation of the compressor's rotational speed for capacity control.

3.2.7 *Computer and Data Processing Room Air Conditioner (CDPR).* An air conditioning unit specifically marketed for cooling Data Centers and ITE that consist of one or more factory-made assemblies, that include a direct expansion evaporator or chilled water-cooling coil, an air-moving device(s) and air-filtering device(s). The air conditioner can include a compressor, condenser, Humidifier, or reheating function. Functions alone or in combination with a cooling plant, can include providing air filtration, air circulation, cooling, and humidity control if the necessary options are included for humidity control.

3.2.8 *Computer Room Air Conditioner (CRAC).* A CDPR that utilizes dedicated compressors and refrigerant cooling Coils rather than chilled-water Coils.

3.2.8.1 *Air-cooled.* A CRAC refrigeration system that has an Air-cooled condenser heat exchanger.

3.2.8.2 *Glycol-cooled.* A CRAC refrigeration system that has a Glycol-cooled condenser heat exchanger.

3.2.8.3 *Water-cooled.* A CRAC refrigeration system that has a Water-cooled condenser heat exchanger.

3.2.9 *Computer Room Air Handler (CRAH).* A CDPR that utilizes chilled-water coils for cooling rather than dedicated compressors.

3.2.10 *Condensate Pump.* A device used to pump condensate or Humidifier drain water, or both from inside the unit to a customer drain outside the unit.

3.2.11 *Connections to Condenser or Condensing Unit.*

3.2.11.1 *Ducted Condenser.* A condenser or condensing unit that Manufacturer's Installation Instructions indicate is intended to exhaust condenser air through a duct(s).

AHRI STANDARD 1360-2022 (I-P)

3.2.11.2 Free Air Discharge Condenser. A condenser or condensing unit that Manufacturer's Installation Instructions do not indicate is intended to exhaust condenser air through a duct(s).

3.2.12 Data Center. A room or building, or portions thereof, including computer rooms being served by the data center systems, serving a total ITE load greater than 10 kW and 20 W/ft² (215 W/m²) of conditioned floor area.

3.2.13 Discharge.

3.2.13.1 Ducted Discharge. A configuration of unit that is marketed for use with discharge ducting and is not Raised Floor Plenum Discharge.

3.2.13.2 Free Air Discharge. A configuration of unit that is marketed only for use without discharge ducting and is not Raised Floor Plenum Discharge.

Note: Can be referred to as non-ducted discharge.

3.2.13.3 Raised Floor Plenum Discharge. A configuration of unit that is marketed to discharge air into an opening in a raised floor plenum.

3.2.14 Electric Reheat Elements. Elements and controls that are located downstream of the cooling coil that can heat the air using electrical power during the dehumidification process.

3.2.15 Fire/Smoke/Isolation Dampers. An assembly including means to open and close the damper mounted at the supply or return duct opening of the equipment.

3.2.16 Flooded Condenser Head Pressure Controls. An assembly, including a receiver and head pressure control valve, used to allow for unit operation at lower outdoor ambient temperatures than the standard operating control system.

3.2.17 Floor-mounted Unit. A type of CDPR with an Indoor Unit that is marketed to be installed on a raised floor, floor stand, or a solid floor inside the building. These have two airflow configuration options: direction and connection. Each unit can be a combination of one direction and two connections (one Discharge from unit and one Return to unit). Discharge from the unit consists of either Ducted Discharge, Free Air Discharge, or Raised Floor Plenum Discharge. Return to the unit consists of either Ducted Return, Free Air Return, or Raised Floor Plenum Return.

Flow direction of the Floor-mounted Unit consists of either:

3.2.17.1 Downflow. A Floor-mounted Unit where return air enters above the top of the cooling coil and discharge air leaves below the bottom of the cooling coil.

3.2.17.2 Horizontal-flow. A Floor-mounted Unit that is neither a Downflow nor an Upflow unit.

3.2.17.3 Upflow. A Floor-mounted Unit where return air enters below the bottom of the cooling coil and discharge air leaves above the top of the cooling coil.

3.2.18 Fluid Economizer. An option provided in a CRAC or CRAH system where a fluid (other than air), cooled external from the unit, provides cooling of the indoor air to reduce or eliminate unit compressor operation when outdoor temperature is low. The fluid can include, but is not limited to, chilled water, water/glycol solution, or refrigerant. An external fluid cooler such as, but not limited to a dry cooler, cooling tower, or condenser is utilized for heat rejection.

Note: Can be referred to as a free cooling coil, econ-o-coil, or economizer.

3.2.19 Harmonic Distortion Mitigation Devices. A high voltage device that reduces harmonic distortion measured at the line connection of the equipment that is created by electronic equipment in the unit.

3.2.20 High-Efficiency Indoor Air Filtration. Indoor air filters with a specification greater than MERV 8 for ducted units and MERV 1 for non-ducted units.

AHRI STANDARD 1360-2022 (I-P)

- 3.2.21** *Humidifier*. A device placed in the supply air stream for moisture evaporation and distribution.
- 3.2.22** *Indoor Unit*. Refers to the part of the system that removes heat from the indoor air stream in split systems and refers to the unit in single package units.
- 3.2.23** *Information Technology Equipment (ITE)*. Includes computers, data storage, servers, and network/communication equipment.
- 3.2.24** *Integrated Net Sensible Coefficient of Performance (iNSenCOP)*. A value that provides a standardized evaluation of the annualized cooling energy efficiency of a unit operated across the specified range of outdoor ambient temperatures (see Informative Appendix G).
- 3.2.25** *Manufacturer's Installation Instructions*. Manufacturer's documents that come packaged with or appear in the labels applied to the unit(s). This includes online manuals if referenced on the unit label or in the documents that come packaged with the unit, and certification reports (information provided to authorities having jurisdiction concerning testing) provided by the manufacturer.
- 3.2.25.1** *Supplemental Test Instructions (STI)*. Additional instructions developed by the manufacturer and certified to the United States Department of Energy (DOE).
- 3.2.25.2** *Manufacturer-specified*. Information provided by the manufacturer in the Manufacturer's Installation Instructions.
- 3.2.26** *Net Sensible Coefficient of Performance (NSenCOP)*. A ratio of the Net Sensible Cooling Capacity in kilowatts to the total power input in kilowatts (excluding reheaters and Humidifiers) at any given set of Rating Conditions.
- 3.2.27** *Net Sensible Cooling Capacity*. The rate, expressed in Btu/h or kW, or both, where the equipment removes sensible heat from the air passing through the unit under specified conditions of operation, including the fan energy dissipated into the conditioned space.
- 3.2.28** *Net Total Cooling Capacity*. The rate, expressed in Btu/h or kW, or both, where the equipment removes total heat from the air passing through the unit under specified conditions of operation, including the fan energy dissipated into the conditioned space.
- 3.2.29** *Non-standard Control Valve*. A pressure or electromechanical water control valve or component in chilled water units used to control unit operation to meet customer specific requirements (such as a three-way valve or a high-pressure valve).
- 3.2.30** *Non-standard Power Transformer*. A device applied to a high voltage load that transforms input electrical voltage to that voltage necessary to operate the load.
- 3.2.31** *Powered Fans*.
- 3.2.31.1** *Powered Exhaust Fan*. Transfers a portion of the building air that is returning to the unit directly to the outside, rather than allowing the air to recirculate to the indoor coil and back to the building.
- 3.2.31.2** *Powered Return Air Fan*. Draws building air into the equipment.
- 3.2.32** *Process Heat Recovery / Reclaim Coils / Thermal Storage*. A heat exchanger located inside the unit that conditions the equipment's supply air using energy transferred from an external source using a vapor, gas, or liquid.
- 3.2.33** *Published Rating*. A statement of the assigned values of those performance characteristics, under stated Rating Conditions, where a unit can be chosen to fit the application. These values apply to all units of same nominal size and type (identification) produced by the same manufacturer. This includes the rating of all performance characteristics shown on the unit or published in specifications, advertising, or other literature controlled by the manufacturer, at stated Rating Conditions.

AHRI STANDARD 1360-2022 (I-P)

3.2.33.1 Application Rating. A rating based on tests performed at rating conditions other than Standard Rating Conditions.

3.2.33.2 Standard Rating. A rating based on tests performed at Standard Rating Conditions.

3.2.34 Rating Conditions. Any set of operating conditions where a single level of performance results and causes only that level of performance to occur.

3.2.34.1 Standard Rating Conditions. Rating Conditions used as the basis of comparison for performance characteristics.

3.2.34.2 Application Rating Conditions. Rating Conditions other than Standard Rating Conditions.

3.2.35 Return.

3.2.35.1 Ducted Return. A configuration of unit that is installed to return air from ductwork or a return plenum.

3.2.35.2 Free Air Return. A configuration of unit that is installed to not return air from ductwork or a return plenum.

Note: Can be referred to as non-ducted return.

3.2.35.3 Raised Floor Plenum Return. A configuration of unit that is installed such that it takes in return air from an opening in a raised floor plenum.

3.2.36 Roof-mounted Unit. A type of single-package CDPR that is not wall-mounted and is marketed for outdoor installation (such as on a roof or a slab).

3.2.37 Standard Air. Air weighing 0.075 lb/ft³ that approximates dry air at 70°F and at a barometric pressure of 29.92 in Hg.

3.2.38 Standard Airflow. The volumetric flowrate of air corrected to Standard Air conditions expressed in standard cubic feet per minute (scfm).

3.2.39 Standard Configuration. A specific configuration for rating of the CDPR basic indoor cooling unit types as defined below and as shown in Appendix C.

3.2.39.1 Ceiling-mounted Unit–ducted Standard Configuration. A Ceiling-mounted Unit with Ducted Discharge and Ducted Return.

3.2.39.2 Ceiling-mounted Unit–nonducted Standard Configuration. A Ceiling-mounted Unit with Free Air Discharge and Free Air Return.

3.2.39.3 Downflow Unit Standard Configuration. A Floor-mounted Unit with Downflow, Raised Floor Plenum Discharge, and Free Air Return.

3.2.39.4 Horizontal-flow Unit Standard Configuration. A Floor-mounted Unit with Horizontal-flow, Free Air Discharge, and Free Air Return.

3.2.39.5 Roof-mounted Unit–ducted Standard Configuration. A Roof-mounted Unit with Ducted Discharge and Ducted Return.

3.2.39.6 Upflow Unit–ducted Standard Configuration. A Floor-mounted Unit with Upflow, Ducted Discharge and Free Air Return.

AHRI STANDARD 1360-2022 (I-P)

3.2.39.7 *Upflow Unit–nonducted Standard Configuration.* A Floor-mounted Unit with Upflow, Free Air Discharge and Free Air Return.

3.2.39.8 *Wall-mounted Unit Standard Configuration.* A Wall-mounted Unit with Free Air Discharge and Free Air Return.

3.2.40 *Total Humidification Capacity.* The unit’s total humidification output operating at Standard Rating Conditions (see Table 3). The mechanical cooling system is disabled to establish this rating.

3.2.41 *Wall-mounted Unit.* A type of CDPR where the Indoor Unit is marketed for installation on or through a wall.

Section 4. Classifications

CDPR units within the scope of this standard shall be classified as shown in Table 1.

AHRI STANDARD 1360-2022 (I-P)

Table 1. Classification of CDPR			
Designation	AHRI Type^{1,2}	Arrangement – Indoor (ID)	Arrangement – Outdoor (OD)
Air-cooled Indoor Package with Remote Condenser	CRC-A ³ CRC-A-FC ³	EVAP ID FAN COMP REHEAT ⁴ HUMIDIFIER ⁴	COND FAN COND REFRIGERANT PUMP ^{4,5}
Air-cooled Indoor Package with Remote Condensing Unit	CRCU-A ³ CRCU-A-FC ³	EVAP ID FAN REHEAT ⁴ HUMIDIFIER ⁴	COND FAN COND COMP REFRIGERANT PUMP ^{4,5}
Air-cooled Indoor Package Self-Contained	CSP-A ³ CSP-A-FC ³	EVAP ID FAN COND FAN COND COMP REHEAT ⁴ HUMIDIFIER ⁴ REFRIGERANT PUMP ^{4,5}	
Air-cooled Outdoor Package Self-Contained Wall-mounted	CSP-A		ELEC/GAS HEAT ⁴ COND FAN ID FAN COMP EVAP COND REFRIGERANT PUMP ^{4,5}
Air-cooled Outdoor Package Self-Contained Roof-mounted	CSP-A		ELEC/GAS HEAT ⁴ COND FAN ID FAN COMP EVAP COND REFRIGERANT PUMP ^{4,5}
Fluid-cooled Indoor Package (attached to customer fluid heat rejection)	CSP-W ³ CSP-W-FC ³	EVAP ID FAN COMP ⁶ FLUID COND ⁶ ECONOMIZER COIL ⁴ REHEAT ⁴ HUMIDIFIER ⁴	CUSTOMER COOLING TOWER OR DRY COOLER ⁷
Indoor Fan Coil	CFC-C	COIL ID FAN REHEAT ⁴ HUMIDIFIER ⁴	CUSTOMER CHILLER
<p>Notes:</p> <ol style="list-style-type: none"> 1. A suffix of "-O" following any of the above classifications indicates equipment not intended for use with field-installed duct systems. 2. A suffix of "-A" indicates Air-cooled condenser, "-W" indicates Water-cooled or Glycol-cooled condenser, "-C" indicates indoor chilled-water coil, and "-FC" indicates free cooling coil (can be additional). 3. For a ducted indoor condenser/condensing unit, append "-DD" and outdoor arrangement moves from outdoor side to indoor side. 4. Optional component. 5. Refrigerant economizer pump can be indoors or outdoors and is only included in "-FC" units. 6. Component can be remote. 7. For "-W" products, outdoor arrangement can move from outdoor side to indoor side. 			

Section 5. Test Requirements

5.1 *Test Requirements.* All tests shall be conducted in accordance with ASHRAE 127 and ASHRAE 37. In the event of conflicting instructions between test standards, this standard takes precedence. Any deviations shall be described and documented in a test report.

5.2 *Heat Rejection Loop Components for Water-Cooled and Glycol-Cooled Units.* Heat rejection loop components other than the fluid-refrigerant condenser coil are not part of the unit or system under test. Electric energy input of Air-cooled fluid coolers, cooling towers or pumps, or both are not included in system power measurements. Instead, water or glycol, as applicable, shall be supplied to the condenser heat exchanger at the temperature conditions specified in Section 6.1.

5.3 *Compressors in the Indoor Unit.* To account for compressor heat, in the following cases:

For systems where the compressor(s) is housed in a part of the unit that the Manufacturer’s Installation Instructions indicate is intended for indoor installation, and the compressor(s) is separately ventilated from the evaporator or condenser airstream (meaning there is a separate airpath for heat to escape the compressor compartment to outside the unit) the enclosure shown in Figure 3 of ASHRAE 37 shall be used.

For systems with the compressor(s) housed in a part of the unit that the Manufacturer’s Installation Instructions indicate is intended for indoor installation, but the compressor(s) is not separately ventilated from the evaporator or condenser airstream, the enclosure shown in Figure 3 of ASHRAE 37 is not required unless the required heat balance between primary and secondary capacity measurements (see Section E3) cannot be achieved. In that case, the enclosure shall be used.

When using the refrigerant enthalpy method as a secondary test method for such systems in accordance with Section 7.5 of ASHRAE 37, the temperature and pressure of the refrigerant leaving the indoor side shall be made downstream of the compressor (meaning discharge measurements rather than suction measurements). Further, for such systems the compressor power shall be included in the “power input, indoor side” term used to calculate total cooling capacity in the equations specified in Section 7.5.4.1 of ASHRAE 37.

5.4 *Installation Instruction Priority.* Units shall be installed per Manufacturer’s Installation Instructions. In the event of conflicting instructions regarding the set-up of the unit under test (excluding charging instructions for split systems, see Section 5.4.1), priority shall be given to installation instructions that appear on the unit’s label over installation instructions that are shipped with the unit.

5.4.1 *Instructions for Split Systems.* In the event of conflicting charging instructions for split systems, priority shall be given to the Manufacturer’s Installation Instructions that are shipped with the unit over the Manufacturer’s Installation Instructions that appear on the unit’s label. For split systems other than mix-matched systems (see Section 5.4.2), if the Manufacturer’s Installation Instructions for the components conflict, priority shall be given to the unit that houses the compressor, except for provisions regarding setting indoor airflow and external static pressure (ESP). For setting indoor airflow and ESP for such a split system, priority shall be given to the Indoor Unit Manufacturer’s Installation Instructions.

5.4.2 *Mix-Matched Systems.* The following provisions apply for split systems consisting of units from different manufacturers. If instructions for the two units differ, priority shall be given to the Manufacturer’s Installation Instructions for the unit that is from the manufacturer that distributed in commerce the tested system. If Manufacturer’s Installation Instructions are provided for only one of the units, then use the provided instructions.

5.5 *Special Test Duct Setup for Certain Upflow Units.* For Upflow Units where there is limited height to meet the ducting requirement of ASHRAE 37 in the test chamber, set up the unit for testing in accordance with Section E2.

5.6 *Test Setup for Free Air Discharge Unit.* Follow the instructions for testing free air discharge units specified in Appendix E, Section E6.

5.7 *Test Setup for Downflow Units.* The unit shall be mounted on a floor stand that is either supplied by the manufacturer or meets specifications provided in the Manufacturer’s Installation Instructions. When setting up the unit, the floor stand shall have discharge out the front, and with the other three sides enclosed and sealed to prevent air leakage. To minimize duct losses, the enclosed sides and bottom of the floor stand shall be insulated externally (meaning insulation outside of the floor stand)

AHRI STANDARD 1360-2022 (I-P)

with thermal insulation having an R-value of at least 13 hr-ft²-°F/Btu. Refer to Figure A-1 of Normative Annex A of ASHRAE 127 for test duct requirements. All duct measurements shall be exclusive of thermal insulation.

5.8 Refrigerant Charging. Unless the unit does not require charging (per Section 5.9), use the tests or operating conditions specified in the Manufacturer's Installation Instructions for charging. If the Manufacturer's Installation Instructions do not specify a test or operating conditions for charging or if Manufacturer's Installation Instructions are not provided, charging shall be conducted at Standard Rating Conditions. If the Manufacturer's Installation Instructions contain two sets of refrigerant charging criteria, one for field installation and one for lab testing, use the field installation criteria. Perform charging of refrigerants only with refrigerant in the liquid state.

If the Manufacturer's Installation Instructions give a Manufacturer-specified range for a charging parameter (such as superheat, sub-cooling, or refrigerant pressure), the average of the range shall be used to determine the refrigerant charge.

If Manufacturer's Installation Instructions are not provided, or the Manufacturer's Installation Instructions do not provide parameters and target values, set superheat to a target value of 12°F for fixed orifice systems or set subcooling to a target value of 10°F for expansion valve systems.

In the event of conflicting information between charging instructions, use the instruction priority order indicated in Section 5.4. Conflicting information is defined as multiple Manufacturer-specified conditions given for charge adjustment where all Manufacturer-specified conditions cannot be met. If such instances of conflicting information occur within the highest-ranking set of instructions where refrigerant charging instructions are provided, follow the hierarchy in Table 2, as appropriate, unless the manufacturer specifies a different priority in the Manufacturer's Installation Instructions. Unless the Manufacturer's Installation Instructions specify a tighter charging tolerance, the tolerances specified in Table 2 shall be used.

Table 2. Tolerances for Charging Hierarchy					
Fixed Orifice			Expansion Valve		
Priority	Parameter	Tolerance	Priority	Parameter	Tolerance
1	Super-heat	± 2.0°F	1	Sub-cooling	± 2.0°F
2	High Side Pressure or Saturation Temperature	± 4.0 psi or ± 1.0°F	2	High Side Pressure or Saturation Temperature	± 4.0 psi or ± 1.0°F
3	Low Side Pressure or Saturation Temperature	± 4.0 psi or ± 1.0°F	3	Low Side Pressure or Saturation Temperature	± 2.0 psi or ± 0.8°F
4	Low Side Temperature	± 2.0°F	4	Approach Temperature ¹	± 1.0°F
5	High Side Temperature	± 2.0°F	5	Charge Weight	± 2.0 oz
6	Charge Weight	± 1% of nominal charge or ± 2.0 oz, whichever is greater	-	-	-
Note: 1. Approach temperature means the refrigerant temperature at the outdoor liquid service port minus the outdoor ambient temperature.					

5.9 Refrigerant Charge for Single Package Unit. Install one or more refrigerant line pressure gauges during the setup of the unit unless either of the following conditions are met:

- 1) the Manufacturer’s Installation Instructions indicate that pressure gauges shall not be installed; or
- 2) charging is based only on parameters, such as charge weight, that don’t require measurement of refrigerant pressure.

Use methods for installing pressure gauge(s) at the required location(s) as indicated in Manufacturer’s Installation Instructions if specified.

The refrigerant charge obtained as described in this section shall then be used to conduct all tests used to determine performance. All tests shall run until completion without further modification. If measurements indicate that refrigerant charge has leaked during the test, repair the refrigerant leak, repeat any necessary set-up steps, and repeat all tests.

5.10 Break-in Period. Conduct a compressor break-in period prior to conducting the test if there is a Manufacturer-specified break-in period. Conduct the break-in period using the Manufacturer-specified duration and conditions; however, the duration shall not exceed twenty hours. When there is a Manufacturer-specified break-in period, each compressor of the unit shall undergo this break-in period. Testing shall not commence until the Manufacturer-specified break-in period is completed.

5.11 Steady-state Operation. Steady-state operation shall be achieved for a valid cooling capacity test. Steady-state operation is achieved when two consecutive thirty-minute data measurement periods (the latter constitutes the official test when cooling capacity is measured) meet the following criteria:

- 1) The difference between the total input power (meaning the cumulative unit input power consumption) measured throughout each data measurement period shall not be greater than 2% of the value measured during the latter of the two data measurement periods.
- 2) The difference between the total net capacity (meaning the cumulative total net capacity calculated using the primary capacity measurement method) measured throughout each data measurement period shall not be greater than 2% of the value measured during the latter of the two data measurement periods.
- 3) All measurements required by the cooling test shall meet the applicable tolerances specified in Table 7.

AHRI STANDARD 1360-2022 (I-P)

- 5.12** *Test Duration.* Test duration shall be thirty minutes for all cooling capacity tests.
- 5.13** *Total System Power Measurement.* Total input system power, kW, shall be measured at the electrical source connection (such as main power circuit breaker(s), main power distribution block(s), main power disconnect(s)) of the CRAC or CRAH under test.
- 5.14** *Units Having a Variable Speed Drive.* The unit shall be tested using a digital power analyzer.
- 5.15** *Head Pressure Control.* For units with condenser head pressure controls, the head pressure controls shall be enabled and operated in automatic mode. Set head pressure controls as specified by the Manufacturer's Installation Instructions. If instructions are not provided, use the as-shipped setting.
- 5.16** *Standard Air Determination.* When correcting measured airflow to Standard Air, the correction shall be based on the air density at the airflow measurement test station.
- 5.17** *Air Condition Measurements.* Instructions for indoor and outdoor air condition measurements are given in Appendix F of this standard.
- 5.18** *Atmospheric Pressure.* For all tests, the ambient conditions shall have a minimum atmospheric pressure of 13.7 psia.
- 5.19** *Total Humidification Capacity Test.* The Total Humidification Capacity measurement shall use the indoor air enthalpy method as prescribed in Section 7.3 of ASHRAE 37. The Humidifier entering water conditions shall be referred from AHRI 640. Testing for Total Humidification Capacity shall be sampled at five-minute intervals for a total of thirteen readings in one hour.
- 5.20** *Instrumentation Accuracy.* In addition to the instrument accuracy requirements specified in Section 5 of ASHRAE 37, measurements shall be made in accordance with the following provisions.
- 5.20.1** *Atmospheric Pressure.* Atmospheric pressure measuring instruments shall be accurate to within $\pm 0.5\%$ of the reading.
- 5.20.2** *Electrical Frequency.* Measurement devices used to measure electrical frequency shall be accurate to within ± 0.2 Hz.
- 5.21** *Supplemental Test Instructions (STI).* STI shall include all instructions that do not deviate from Manufacturer's Installation Instructions but provide additional specifications for test standard requirements allowing more than one option, and all deviations from Manufacturer's Installation Instructions necessary to comply with steady state requirements. STI shall provide steady operation that matches the average performance that can be obtained without deviating from the Manufacturer's Installation Instructions. STI shall not include instructions that deviate from Manufacturer's Installation Instructions other than those necessary to comply with steady state requirements.

Section 6. Rating Requirements

- 6.1** *Standard Ratings.* Standard Ratings shall be established at the standard Rating Conditions specified in Table 3 and Table 4. These standard Rating Conditions are based on different design operating temperatures for different types of CDPR units. Where direct expansion equipment is provided in more than one assembly and the separate assemblies shall be used together, the requirements of rating outlined in this standard are based upon the use of matched assemblies.

Minimum external static pressure requirements are specified in Table 5. Outdoor air external static pressure requirements for units with ducted condensers are specified in Table 6.

Mounting Location	Standard Configuration	Cooling (Return Dry-bulb / Dew-point) ¹ , °F	Humidification (Return Dry-bulb / Dew-point), °F
Floor-mounted Unit	Upflow unit–nonducted	75.0 / 52.0	75.0 / 42.0
	Upflow unit–ducted	85.0 / 52.0	
	Downflow unit	85.0 / 52.0	
	Horizontal-flow unit	95.0 / 52.0	
Roof-mounted Unit	Roof-mounted unit–ducted	85.0 / 52.0	
Wall-mounted Unit	Wall-mounted unit	75.0 / 52.0	
Ceiling-mounted Unit	Ceiling-mounted unit–ducted	75.0 / 52.0	
	Ceiling-mounted unit–non-ducted		

Note:

- If measuring wet-bulb temperature instead of dew point temperature, calculate the return air wet-bulb temperature test condition in accordance with ASHRAE Fundamentals 2017, using the specified dew point temperature and the measured atmospheric pressure.

System Type	Fluid Condition	Test Condition
Air-cooled units	Entering outdoor ambient dry-bulb temperature, °F	95.0
	Entering outdoor ambient wet-bulb temperature, °F	75.0 ¹
Water-cooled units	Entering water temperature, °F	83.0
	Temperature rise, °F	12.0
Glycol-cooled units	Entering glycol temperature, °F	104.0
	Temperature rise, °F	11.0
	Glycol solution concentration	40% Propylene Glycol by Volume
Chilled-water units	Entering water temperature, °F	50.0
	Temperature rise, °F	12.0

Note:

- The outdoor air wet-bulb temperature condition is not required when testing Air-cooled condensers that do not evaporate condensate. For single package units that do not reject condensate to the outdoor coil, where all or part of the indoor section of the equipment is located in the outdoor room, maintain an outdoor room dew point temperature of 52°F.

Table 5. Minimum External Static Pressure Requirements		
Standard Configuration	Net Sensible Cooling Capacity, Btu/h	Minimum External Static Pressure, in H ₂ O
Horizontal-flow Up-flow non-ducted Ceiling-mounted non-ducted Wall-mounted	All	0.0
Up-flow ducted Roof-mounted	< 80,000	0.3
	≥ 80,000 and < 295,000	0.4
	≥ 295,000	0.5
Down-flow	All	0.2
Ceiling-mounted ducted	≤ 29,000	0.1
	≥ 29,000 and < 65,000	0.2
	≥ 65,000	0.3

Table 6. Outdoor Air ESP Requirements for Units with Ducted Condensers	
Indoor Unit Configuration	ESP, in H ₂ O
Ceiling-mounted	0.5
All other configurations	0.0

6.2 Standard Capacity Ratings. For each combination of Standard Configuration (Table 3) and system type (Table 4) a single capacity rating shall be established at the Standard Rating Conditions.

Cooling tests shall be conducted without operating the reheating or humidification (whether or not the unit operates with heat addition) functions of the air conditioner.

6.3 Standard Efficiency Ratings for NSenCOP. Calculate NSenCOP by dividing the Net Sensible Cooling Capacity expressed in watts by the total power expressed in watts, both measured over the thirty-minute test period.

6.3.1 Total Power. The total power used to calculate NSenCOP shall be the sum of power input to the compressor(s) and fan(s), plus system controls and other any other components required by Appendix D. If the unit contains an integral Condensate Pump, the power to operate the pump shall be included in the system total power calculation.

6.3.2 Air-cooled Units. Include all the Indoor Unit power and, for split systems, the Air-cooled condenser/condensing unit power.

6.3.3 Water-cooled Units. To account for the energy consumption of cooling tower fan(s) and a heat rejection loop, add an allowance of 5% of the unit Net Sensible Cooling Capacity to the unit total input power (expressed in watts) used to calculate NSenCOP.

6.3.4 Glycol-cooled Units. To account for the energy consumption of dry cooler fan(s) and a heat rejection loop, add an allowance of 7.5% of the unit Net Sensible Cooling Capacity to the unit total input power (expressed in watts) used to calculate NSenCOP.

6.3.5 Chilled water Units. To account for the energy consumption of chilled water pump(s), add an allowance (determined per Equation 1 below) to the unit total input power (expressed in watts) used to calculate NSenCOP.

The equation for chilled water pump power is as follows:

$$kW_{\text{pump}} = \dot{M} \cdot H \cdot SG / (A \cdot PE) \tag{1}$$

Where:

A = 5310 Conversion Factor, gpm·ft H₂O/kW

AHRI STANDARD 1360-2022 (I-P)

H	=	Pressure drop from the entrance to the exit of the unit, ft H ₂ O
M	=	Flow rate, gpm
PE	=	Pump Efficiency, 65% [0.65]
SG	=	Specific gravity of fluid
kW _{pump}	=	Pump power input, kW

6.4 *Standard Humidification System Capacity Ratings.* Humidification capacities shall be established at the standard Rating Conditions as specified in Table 3 and Table 4 without the cooling system in operation.

6.4.1 *Unit Airflow Rate.* Airflow shall remain as specified in Section 6.2.4 unless the standard control(s) provided with the Indoor Unit automatically change the airflow.

6.4.2 *Water Quality.* The water quality, conductivity and dissolved solids for the test are stated in AHRI 640.

6.5 *Air Filter Standard Ratings.* Published air filter Standard Ratings shall be those defined in ASHRAE 52.2. At any Rating Condition described by this standard, the system shall be rated with clean filters of the manufacturer's choice. Optional filter applications can be shown based on tests or engineering calculations. For this standard, a minimum MERV 8 rated filter sized to match the unit or system filter rack shall be used. Free Air Discharge units shall be rated with a minimum MERV 1 rating.

6.6 *Voltage and Frequency.* Standard Ratings shall be determined at the unit nameplate rated voltages and frequency.

For air-conditioners with dual voltage ratings at the same frequency, Standard Rating tests shall be performed at both voltages or at the lower of the two voltages if only a single standard rating is to be published.

6.7 *Application Ratings.* Units can be rated at Application Rating Conditions other than those shown above and can be published as Application Ratings and shall be based on calculations or tests using techniques described by this standard, with the method used to create the Application Rating clearly stated.

6.8 *Test Tolerances.*

Test operating tolerance is the maximum permissible range a measurement can vary over the specified test interval. Specifically, the difference between the maximum and minimum sampled values shall be less than or equal to the specified test operating tolerance. If the operating tolerance is expressed as a percentage, the maximum allowable variation is the specified percentage of the average value of the measured test parameter.

Test condition tolerance is the maximum permissible difference between the average value of the measured test parameter and the specified test condition. If the condition tolerance is expressed as a percentage, the condition tolerance is the specified percentage of the test condition.

Tolerances specified in this standard supersede tolerances specified in ASHRAE 37. Test operating tolerances and condition tolerances are specified in Table 7.

The saturated refrigerant temperature shall be evaluated based on the pressure transducer located between the indoor coil and the compressor.

Table 7. Tolerances		
Measurement	Test Operating Tolerance	Test Condition Tolerance
Outdoor dry-bulb temperature (°F): Entering	2.0	0.5
Outdoor wet-bulb temperature (°F): Entering	1.0	0.3 ¹
Outdoor dew point temperature (°F) ² : Entering	-	3.0
Indoor dry-bulb temperature (°F): Entering	2.0	0.5
Indoor wet-bulb temperature (°F) ³ : Entering	1.0	0.3
Indoor dew point temperature (°F) ³ : Entering	2.6	0.8
condenser water/glycol or chilled water temperature (°F): Entering	0.5	0.2
Temperature Rise		0.2
Saturated refrigerant temperature corresponding to the measured indoor side pressure ^{3,4} (°F)	3.0	0.5
Liquid refrigerant temperature ^{3,4} (°F)	0.5	0.2
External static pressure (in H ₂ O)	0.05	See Sections E6.2 and E5
Electrical voltage (percent of reading)	2.0	1.0
Electrical frequency (Hz) ⁵	0.4	0.2
Liquid flow rate (percent of reading)	2.0	-
Nozzle pressure drop (percent of reading)	2.0	-
Notes:		
<ol style="list-style-type: none"> 1. Only applicable when testing equipment that rejects condensate to the outdoor coil. 2. Tolerance only applies when testing single package units that do not reject condensate to the outdoor coil where all or part of the indoor section of the equipment is in the outdoor chamber. 3. Per Note 1 to Table 3, either indoor air wet-bulb temperature or indoor air dew point temperature can be measured. Use the applicable tolerances in this table for the parameter that is measured. 4. Tolerance applies only for the compressor calibration and refrigerant enthalpy methods. 5. When using electrical generators, tolerances can be doubled. 		

6.9 Uncertainty. When verifying the ratings by testing a sample unit, uncertainties shall be addressed. Verification tests shall be conducted in a laboratory that meets the requirements referenced in this standard and ASHRAE 37 and shall demonstrate performance with an allowance for uncertainty. The following make up the uncertainty for products covered by this standard.

6.9.1 Uncertainty of Measurement. When testing a unit, there are variations that result from instrumentation as well as measurements of temperatures, pressure, and flow rates.

6.9.2 Uncertainty of Test Rooms. Due to setup variations, the same unit tested in multiple rooms is not expected to yield the same performance.

6.9.3 Uncertainty Due to Manufacturing. During the manufacturing of units, there are variations due to manufacturing production tolerances that impact the performance of the unit.

6.9.4 Uncertainty of Performance Simulation Tools. Due to the large complexity of options, manufacturers shall use performance prediction tools such as an alternative efficiency determination method (AEDM).

6.10 Verification Testing. To comply with this standard, single sample production verification tests, shall meet the Standard Rating performance metrics shown in Table 8 with the listed acceptance criteria

Table 8: Uncertainty Allowances		
Performance Metric	Uncertainty Allowance	Acceptance Criteria
Net Sensible Cooling Capacity	5%	≥ 95%
NSenCOP	5%	≥ 95%

6.11 *Manufacturer’s Installation Instructions.* Certified parameters shall not deviate from the Manufacturer’s Installation Instructions.

Section 7. Minimum Data Requirements for Published Ratings

7.1 *Minimum Data Requirements for Published Ratings.* As a minimum, Published Ratings shall include the published values shown in Table 9. Standard Configurations shall be rated at the appropriate standard Rating Conditions for that Standard Configuration (per Appendix C). Published Ratings and final reported test values shall be rounded to the number of significant figures shown in this table.

All claims to ratings within the scope of this standard shall include the statement “Rated in accordance with AHRI Standard 1360 (I-P).” All claims to ratings outside the scope of this standard shall include the statement “Outside the scope of AHRI Standard 1360 (I-P).”

AHRI STANDARD 1360-2022 (I-P)

Table 9. Published Ratings							
Published Values	Units	Significant Figures	Air-Cooled Units	Water-Cooled Units	Glycol-Cooled Units	Chilled Water Units	Fluid Economizer Units
General	-						
Model Number	-	-	■	■	■	■	■
Refrigerant Designation	-	-	■	■	■		■
Voltage	V	3	■	■	■	■	■
Frequency	Hz	2	■	■	■	■	■
Capacity	-	-	-	-	-	-	-
Net Total Cooling Capacity	But/h or kW, or both	3	■	■	■	■	■
Net Sensible Cooling Capacity	Btu/h or kW, or both	3	■	■	■	■	■
Total Humidification Capacity	lb/h	3	■	■	■	■	■
Efficiency	-	-	-	-	-	-	-
NSenCOP	kW/kW	3	■	■	■	■	■
Air	-	-	-	-	-	-	-
Unit Airflow Rate	scfm	-	■	■	■	■	■
External Static Pressure	in H ₂ O	2	■	■	■	■	■
Indoor Return Dry-bulb Temperature	°F	-	■	■	■	■	■
Indoor Return Dew point or Wet-bulb Temperature, or both	°F	-	■	■	■	■	■
Outdoor Ambient Dry-bulb Temperature	°F	-	■				
Fluid	-	-	-	-	-	-	-
Fluid Flow Rate	gpm	-		■	■	■	■
Fluid Pressure Drop	ft H ₂ O	2		■	■	■	■
Entering Water or Glycol Temperature	°F	-		■	■	■	■
Glycol Solution Type	-	-			■		
Glycol Solution Concentration	%	2			■		

Section 8. Operating Requirements

8.1 *Operating Requirements.* CDPR Equipment shall comply with the provisions of this section such that any production unit shall meet the requirements detailed herein.

8.2 *Loss of Power Restart Time (Cooling).* CDPR Equipment shall operate for a minimum of one hour at Standard Rating Conditions for the appropriate Standard Rating Condition. Then all power to the equipment shall be interrupted for a minimum period of thirty seconds and a maximum of one minute and then be restored. The equipment shall resume cooling, within ten minutes of restoration of power and shall then operate continuously for one hour. Standard condition tolerances are not required to be maintained for the initial period after the restart has occurred.

8.3 *Low Temperature Start (Cooling).* Air Cooled CDPR Equipment operating at indoor standard Rating Conditions for the appropriate standard Rating Condition shall have the indoor blower running and the compressors off. During this time, the condenser/condensing unit shall be subjected to a four hour continuous exposure (soak) at 40°F outdoor ambient with controls set per the Manufacturer's Installation Instructions. On a call for cooling, equipment shall startup and resume compressor cooling within thirty minutes and operate for one hour without further interruption. Standard condition tolerances are not required to be maintained for the initial period after the restart has occurred. If a manufacturer chooses to confirm equipment operation below 40°F, the same process can be used.

8.4 *High Temperature Operation (Cooling).* Air Cooled CDPR Indoor Units can be matched with larger condenser Coils (and fans) to allow the system to operate at elevated entering outdoor ambient dry-bulb temperatures. Testing shall verify that Indoor Units and condensers/condensing units designed to operate at 125.6°F entering outdoor ambient dry-bulb temperature can operate at standard indoor Rating Conditions (see Table 3) for that Standard Configuration for fifteen minutes. This test shall follow the test at standard Rating Condition test by raising the entering outdoor ambient dry-bulb temperature. Loss of power restart time test shall not be conducted during the high temperature operation (cooling) test.

Section 9. Marking and Nameplate Data

As a minimum, the following information shall be shown in a conspicuous place on the equipment:

- 1) Name or trade name of manufacturer
- 2) Manufacturer's model number

Nameplate voltages for 60 Hertz systems shall include one or more of the equipment nameplate voltage ratings shown in Table 1 of AHRI Standard 110. Nameplate voltages for 50 Hertz systems shall include one or more of the utilization voltages shown in Table 1 of IEC Standard 60038.

Section 10. Conformance Conditions

While conformance with this standard is voluntary, conformance shall not be claimed or implied for products or equipment within the standard's *Purpose* (Section 1) and *Scope* (Section 2) unless such product claims meet all of the requirements of the standard and all of the testing and rating requirements are measured and reported in complete compliance with the standard. Any product that has not met all the requirements of the standard cannot reference, state, or acknowledge the standard in any written, oral, or electronic communication.

APPENDIX A. REFERENCES – NORMATIVE

A1 Listed here are all standards, handbooks, and other publications essential to the formation and implementation of the standard. All references in this appendix are considered part of the standard.

A1.1 AHRI Standard 110-2016, Air-Conditioning, Heating, and Refrigerating Equipment Nameplate Voltages, 2016, Air-Conditioning Heating & Refrigeration Institute, 2311 Wilson Blvd., Suite 400, Arlington, VA 22201, USA.

A1.5 AHRI Standard 640-2017, *Performance Rating of Commercial and Industrial Humidifiers*, 2017, Air-Conditioning Heating & Refrigeration Institute, 2311 Wilson Blvd., Suite 400, Arlington, VA 22201, USA.

A1.6 ANSI/ASHRAE Standard 127-2020, *Method of Testing Method of Testing for Rating Computer and Data Processing Room Unitary Air Conditioners*, 2020, ASHRAE, 180 Technology Parkway, Peachtree Corners, GA 30092, USA.

A1.7 ANSI/ASHRAE Standard 37-2009 (RA 2019), *Method for Testing and Rating Unitary Air-Conditioning and Heat Pump Equipment*, 2009 (Reaffirmed 2019), ASHRAE, 180 Technology Parkway, Peachtree Corners, GA 30092, USA.

A1.8 ANSI/ASHRAE Standard 41.1-2020, *Standard Method for Temperature Measurement*, 2020, American Society of Heating, Refrigerating, and Air-Conditioning Engineers, Inc., 180 Technology Parkway, Peachtree Corners, GA 30092, USA.

A1.9 ANSI/ASHRAE Standard 41.6-2021, *Standard Method for Humidity Measurement*, 2021, ASHRAE, 180 Technology Parkway, Peachtree Corners, GA 30092, USA.

A1.9 ANSI/ASTM Standard B117-2019, *Standard Practice for Operating Salt Spray (Fog) Apparatus*, 2019, ASTM International, 100 Barr Harbor Drive, PO Box C700, West Conshohocken, PA, 19428-2959, USA.

A1.10 ANSI/ASTM Standard G85-2019, *Standard Practice for Operating Salt Spray (Fog) Testing*, 2019, ASTM International, 100 Barr Harbor Drive, PO Box C700, West Conshohocken, PA, 19428-2959, USA.

A1.13 ASHRAE Handbook Fundamentals - 2021, *Fundamentals*, 2021, ASHRAE, 180 Technology Parkway, Peachtree Corners, GA 30092, USA

A1.14 ASHRAE Terminology. ASHRAE. Accessed March 11, 2022.
<https://www.ashrae.org/technicalresources/free-resources/ashrae-terminology>.

A1.15 IEC Standard 60038-2009, *IEC Standard Voltages*, 2009, International Electrotechnical Commission, 3, rue de Varembe, PO Box 131, CH-1211 Geneva 20, Switzerland.

APPENDIX B. REFERENCES – INFORMATIVE

B1 Listed here are standards, handbooks and other publications which may provide useful information and background but are not considered essential. References in this appendix are not considered part of the standard.

B1.1 ASHRAE DATACOM Series Book #3, *Design Considerations for Datacom Equipment Centers*. ASHRAE, 180 Technology Parkway, Peachtree Corners, GA 30092, U.S.A

B1.2 ASHRAE 2019 HVAC Applications. ASHRAE, 180 Technology Parkway, Peachtree Corners, GA 30092, U.S.A

APPENDIX C. STANDARD CONFIGURATIONS – NORMATIVE

C1 Purpose. The purpose of this appendix is to prescribe the requirements for the configuration of a unit (Standard Configuration) that is required for determining the Standard Rating. See Section 3 for definitions of Standard Configurations. All units, regardless of alternate configurations, shall be categorized and rated in one of the eight Standard Configurations.

C2 Standard Configurations. As shown in Section 3, CDPR can have a variety of mounting and airflow configurations that allow operation across applications. Table C1, Table C2, Table C3, and Table C4 show the eight Standard Configurations defined by this standard. Other configurations (Application Configurations) are within the scope of this Standard but are optional for determining Application Ratings.

C2.1 Ceiling-mounted Units and Configurations. Figure C1, Figure C2, and Table C1 show Ceiling-mounted units.

Figure C1 shows a representation of Ceiling-mounted Standard Configurations for a Ceiling-mounted Unit–ducted. Application Configuration shall be rated as a Ceiling Mounted Unit–ducted Standard Configuration for a Ceiling Mounted Unit with a connection of Ducted Discharge and Free Air Return.

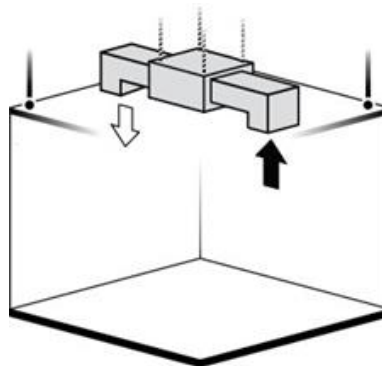

Figure C1. Ceiling-mounted Unit–ducted

Figure C2 shows a representation of a Ceiling-mounted Standard Configurations for a Ceiling-mounted Unit–nonducted. Connections pictured below unit in Figure C2 are not ductwork and represent free air supply and return plenums / grills that can protrude below the ceiling. Application Configuration shall be rated as a Ceiling-mounted Unit–nonducted Standard Configuration for a Ceiling-mounted Unit with a connection of Free Air Discharge and Ducted Return.

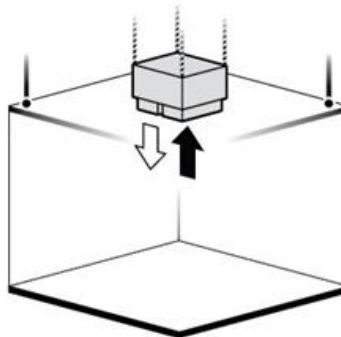

Figure C2. Ceiling-mounted Unit–nonducted

Table C1 shows configurations for Ceiling-mounted Units.

Table C1. Ceiling-mounted Standard Configurations	
Connections	Type
Ducted Discharge and Ducted Return	Ceiling-mounted Unit–ducted Standard Configuration¹
Ducted Discharge and Free Air Return	Application Configuration
Free Air Discharge and Ducted Return	Application Configuration
Free Air Discharge and Free Air Return	Ceiling-mounted Unit-nonducted Standard Configuration¹
Note: 1. The bolded text in the Type column represent the Standard Configuration.	

C2.2 *Downflow Units and Floor-mounted Configurations.* Figure C3, Figure C4, Figure C5, and Table C2 Floor-mounted Standard Configurations.

Figure C3 shows a pictorial representation of a Downflow Unit. Application Configurations shall be rated as a Downflow Unit Standard Configuration for the following connections with downflow air direction:

- Raised Floor Plenum Discharge and Ducted Return
- Ducted Discharge and Ducted Return
- Ducted Discharge and Free Air Return
- Free Air Discharge and Free Air Return
- Free Air Discharge and Ducted Return

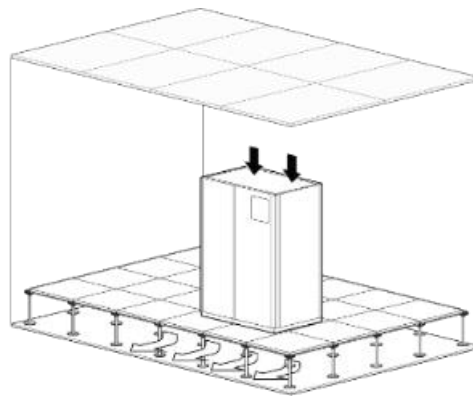

Figure C3. Downflow Unit

Figure C4 shows a Horizontal-flow Unit. Application Configurations shall be rated as a Horizontal-flow Unit Standard Configuration for the following connections with horizontal flow air direction:

- Ducted Discharge and Ducted Return
- Ducted Discharge and Free Air Return
- Free Air Discharge and Ducted Return

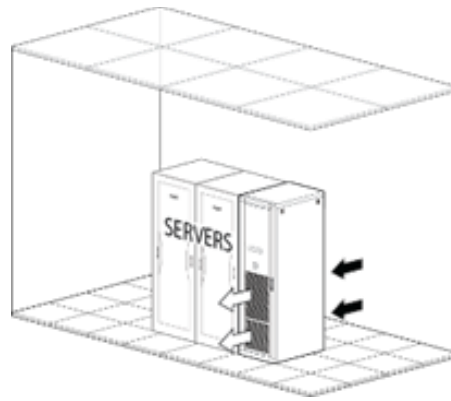

Figure C4. Horizontal-flow Unit

Figure C5 shows Upflow Unit-ducted or Upflow Unit-nonducted. Application Configurations shall be rated as an Upflow Unit-Ducted Standard Configuration for the following connections with upflow air direction:

- Ducted Discharge and Raised Floor Plenum Return
- Ducted Discharge and Ducted Return
- Free Air Discharge and Raised Floor Plenum Return
- Free Air Discharge and Ducted Return

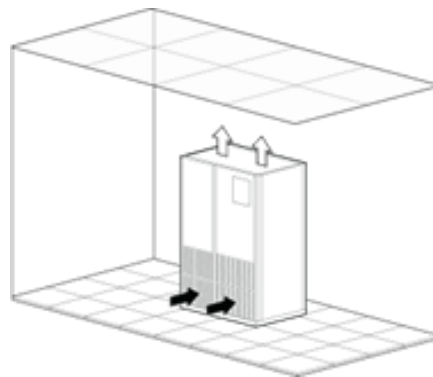

Figure C5. Upflow Unit-ducted or Upflow Unit-nonducted

Table C2 shows configurations for Floor-mounted Units.

Table C2. Floor-mounted Standard Configurations			
Connection	Airflow Direction		
	Downflow	Horizontal-flow	Upflow
Raised Floor Plenum Discharge and Ducted Return	Application Configuration	N/A ¹	N/A ¹
Raised Floor Plenum Discharge and Free Air Return	Downflow Unit Standard Configuration²	N/A ¹	N/A ¹
Ducted Discharge and Raised Floor Plenum Return	N/A ¹	N/A ¹	Application Configuration
Ducted Discharge and Ducted Return	Application Configuration	Application Configuration	Application Configuration
Ducted Discharge and Free Air Return	Application Configuration	Application Configuration	Upflow Unit–ducted Standard Configuration²
Free Air Discharge and Raised Floor Plenum Return	N/A ¹	N/A ¹	Application Configuration
Free Air Discharge and Ducted Return	Application Configuration	Application Configuration	Application Configuration
Free Air Discharge and Free Air Return	Application Configuration	Horizontal-flow Unit Standard Configuration²	Upflow Unit–nonducted Standard Configuration²

Notes:

1. N/A = Not Applicable.
2. The bolded text in the Airflow Direction columns represent the Standard Configuration.

C2.3 *Wall-mounted Units and Configuration.* Figure C6 and Table C3 show a Wall-mounted Standard Configuration.

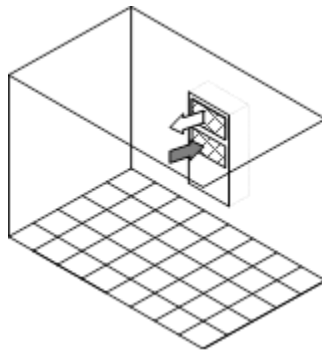

Figure C6. Wall-mounted Unit

Table C3. Wall-mounted Standard Configurations	
Connection	Type
Free Air Discharge and Free Air Return	Wall-mounted Unit Standard Configuration¹
Note: 1. The bolded text the Type column represent the Standard Configuration.	

C2.4 Roof-mounted Units and Standard Configuration. Figure C7 and Table C4 show Roof-mounted Standard Configurations. Roof-mounted Unit–ducted Standard Configuration is the Standard Configuration.

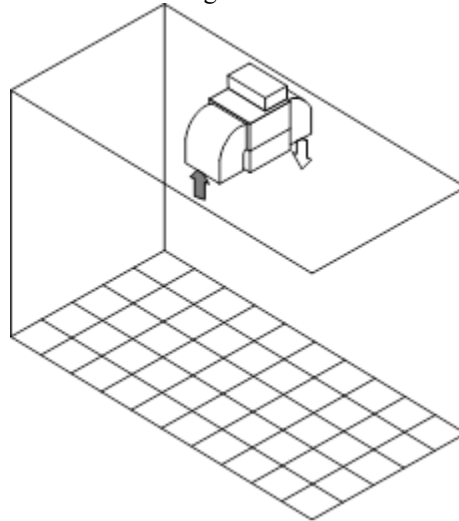

Figure C7 Roof-mounted Unit

Table C4. Roof-mounted Standard Configurations	
Connection	Type
Ducted Discharge and Ducted Return	Roof-mounted Unit–ducted Standard Configuration¹
Note: 1. The bolded text in this table represents the Standard Configuration.	

APPENDIX D. UNIT CONFIGURATION FOR STANDARD EFFICIENCY DETERMINATION - NORMATIVE

Purpose. Use this appendix to determine the combination of different components for determining representations, in accordance with the requirements of the United States Department of Energy, that include the Standard Rating Cooling Capacity and NSenCOP efficiency metric.

D1 *Optional System Features.* The following features are optional during testing. Individual models with these features can be represented separately as a unique basic model or certified within the same basic model as otherwise identical individual models without the feature pursuant to the definition of basic model, as specified in 10 CFR 431.92.

If an otherwise identical model (within the same basic model) without the feature is distributed in commerce, test the otherwise identical model.

If an otherwise identical model (within the basic model) without the feature is not distributed in commerce, conduct tests with the feature present but configured and de-activated to minimize (partially or totally) the impact on the results of the test. Alternatively, the manufacturer can indicate in the STI that the test is conducted using a specially built otherwise identical unit that is not distributed in commerce and does not have the feature.

D1.1 *Chilled Water Dual Cooling Coil.*

D1.2 *Air Economizers.* An Air Economizer installed during the test shall be in the 100% return position with outside air dampers closed and sealed using tape to block any leakage.

D1.3 *Process Heat Recovery / Reclaim Coils / Thermal Storage.* If such a feature is present for testing, the heat exchanger shall be disconnected from the heat source.

D1.4 *Evaporative Pre-cooling of Condenser Intake Air.* Water is evaporated into the air entering the Air-cooled condenser to lower the dry bulb temperature and thereby increase efficiency of the refrigeration cycle. If an evaporative pre-cooler is present for testing, operate disconnected from a water supply, meaning, without active evaporative cooling.

D1.5 *Flooded Condenser Head Pressure Controls.*

D1.6 *Humidifier.* The device can require building steam, water, hot water, electricity, or gas to operate. If such a feature is present for testing, the Humidifier shall be deactivated.

D1.7 *Steam or Hot Water Hydronic Heat Coils.*

D1.8 *Refrigerant Reheat Coils.* If this feature is present for testing, Refrigerant Reheat Coils shall be de-activated to provide the minimum reheat achievable by the system controls.

D1.9 *Electric Reheat Elements.*

D1.10 *Powered Exhaust/Powered Return Air Fans.* If a Powered Exhaust Fan or a Powered Return Air Fan is present for testing, the unit shall be set up as indicated by the STI.

D1.11 *Coated Coils.* A coating for this purpose will be defined based on what is deemed to pass ASTM B117 or ASTM G85 test of 500 hours or more.

D1.12 *Harmonic Distortion Mitigation Devices.* These devices can be a requirement of the power distribution system supplying the unit. Harmonic Distortion Mitigation Devices shall be removed for testing.

D1.13 *Non-standard Power Transformer.*

D1.14 *Condensate Pump.* Condensate Pumps are only an optional feature if the manufacturer distributes in

AHRI STANDARD 1360-2022 (I-P)

commerce individual models within the basic model without a Condensate Pump. If the basic model is only distributed in commerce with a Condensate Pump, then the Condensate Pump shall be present and installed for testing.

D1.15 *Non-standard Control Valves/Components in Chilled Water Units.*

D1.16 *Compressor Variable Frequency Drive (VFD).* If the manufacturer chooses to make representations for performance at part-load or low-ambient conditions, or both (such as, using the iNSenCOP metric), compressor VFDs shall be treated consistently for all cooling capacity tests for the basic model (meaning if the compressor VFD is present and active for the part-load or low-ambient tests, or both, shall be present and active for the NSenCOP test).

D1.17 *Fire/Smoke/Isolation Dampers.* If a fire/smoke/isolation damper is present for testing, set the damper in the fully open position.

D1.18 *High-Efficiency Indoor Air Filtration.*

D2 *Non-Standard Indoor Fan Motors for CRAC Units.* The standard indoor fan motor is the motor specified in the Manufacturer’s Installation Instructions for testing and shall be distributed in commerce as part of a particular model. A non-standard motor is an indoor fan motor that is not the standard indoor fan motor and that is distributed in commerce as part of an individual model within the same basic model. The minimum allowable efficiency of any non-standard indoor fan motor shall be related to the efficiency of the standard motor as specified in either Section D2.1 (meaning for non-standard indoor fan motors) or Section D2.2 (meaning for non-standard indoor integrated fan and motor combinations). If the non-standard motor does not meet the requirements of Equation D1 or Equation D2, then a separate standard model shall be created by the manufacturer for that motor combination. If the standard indoor fan motor can vary fan speed through control system adjustment of motor speed, all non-standard indoor fan motors shall allow speed control (including with the use of VFD).

D2.1 *Determination of Motor Efficiency for Non-standard Indoor Fan Motors.*

Standard and non-standard indoor fan motor efficiencies shall be based on the test procedures indicated in Table D1.

Air-over motors shall be tested to the applicable test procedure based on the motor’s phase count and horsepower, except that the NEMA MG1-2016, Supplement 2017 procedure for air-over motor temperature stabilization shall be used rather than the temperature stabilization procedure specified in the applicable test procedure based on the motor’s phase count and horsepower. The NEMA MG1-2016, Supplement 2017 procedure for air-over motor temperature stabilization offers three options – the same option shall be used by the manufacturer for both the standard and non-standard motor.

BLDC motors and ECMs shall be tested and rated for efficiency at full speed and full rated load. CSA C747-09 can be applied to motors ≥ 1 hp.

Reference motor efficiencies shall be determined for the standard and non-standard indoor fan motor as indicated in Table D1.

Non-standard motor efficiency shall meet the criterion in Equation D1.

$$\eta_{non-standard} \geq \frac{\eta_{standard} - \eta_{reference standard}}{1 - \eta_{reference standard}} \cdot (1 - \eta_{reference non-standard}) + \eta_{reference non-standard} \quad \mathbf{D1}$$

Where:

$\eta_{standard}$	= the tested efficiency of the standard indoor fan motor
$\eta_{non-standard}$	= the tested efficiency of the non-standard indoor fan motor
$\eta_{reference standard}$	= the reference efficiency from Table D1 for the standard indoor fan motor
$\eta_{reference non-standard}$	= the reference efficiency from Table D1 for the non-standard indoor fan motor

Table D1 – Test Procedures and Reference Motor Efficiency		
Motor – Standard or Non-standard	Test Procedure	Reference Motor Efficiency¹
Single Phase ≤ 2 hp	10 CFR 431.444	Federal standard levels for capacitor-start capacitor-run and capacitor-start induction run, 4 pole, open motors at 10 CFR 431.446
Single Phase > 2 hp and ≤ 3 hp	10 CFR 431.444	Federal standard levels for polyphase, 4 pole, open motors at 10 CFR 431.446.
Single Phase > 3hp	10 CFR 431.444	Federal standard levels for 4 pole, open motors at 10 CFR 431.25(h).
Polyphase ≤ 3 hp for cases where the standard or non-standard indoor fan motor, or both is <1 hp	10 CFR 431.444	Federal standard levels for polyphase, 4 pole, open motors at 10 CFR 431.446.
Polyphase ≤ 3 hp for cases where both the standard and non-standard indoor fan motor are ≥ 1 hp	10 CFR 431.444	For standard or non-standard 2-digit frame size motors, or both (except 56-frame enclosed ≥ 1 hp) ≤3 hp: Federal standard levels for polyphase, 4 pole open motors at 10 CFR 431.446
	Appendix B to Subpart B of 10 CFR 431	For all other standard or non-standard motors ≤3 hp, or both: Federal standard levels for 4 pole, open motors at 10 CFR 431.25(h).
Polyphase > 3 hp	Appendix B to Subpart B of 10 CFR 431	Federal standard levels for 4 pole, open motors at 10 CFR 431.25(h).
BLDC ² motor or ECM ³ ≥ 1 hp	CSA C747-09	Federal standard levels for 4 pole, open motors at 10 CFR 431.25(h).
BLDC motor or ECM < 1 hp	CSA C747-09	Use Table D2.
<p>Notes:</p> <ol style="list-style-type: none"> For standard or non-standard motors with horsepower ratings between values given in the references, use the steps at 10 CFR 431.446(b) to determine the applicable reference motor efficiency meaning, use the efficiency of the next higher reference horsepower for a motor with a horsepower rating at or above the midpoint between two consecutive standard horsepower ratings or the efficiency of the next lower reference horsepower for a motor with a horsepower rating below the midpoint between two consecutive standard horsepower ratings. Brushless DC (BLDC) permanent magnet motor. Electronically commutated motor. 		

Table D2– BLDC Motor and ECM – Fractional hp – Reference Efficiencies	
Motor hp	Reference Motor Efficiency ^{1,2}
0.25	78.0
0.33	80.0
0.50	82.5
0.75	84.0

Notes:

1. For standard or non-standard motors with horsepower ratings between values given in Table D2, use the steps at 10 CFR 431.446(b) to determine the applicable reference motor efficiency (meaning, use the efficiency of the next higher reference horsepower for a motor with a horsepower rating at or above the midpoint between two consecutive standard horsepower ratings or the efficiency of the next lower reference horsepower for a motor with a horsepower rating below the midpoint between two consecutive standard horsepower ratings).
2. For BLDC motors and ECMs > 0.75 and < 1 hp, use Table D2 for motors < 0.875 hp, and use Federal standard levels for 1 hp, 4 pole, open motors at 10 CFR 431.25(h) for motors ≥ 0.875 hp.

D2.2 Comparison of the Fan Input Power of the Standard Indoor Fan and a Non-standard Indoor Fan at a Single Duty Point If At Least One Fan is an Integrated Fan and Motor (IFM). The fan input power of the standard and non-standard fans shall be compared using one of the methods listed in Table D3 at a duty point determined per the requirements of Section D2.2.2. The ratio of the fan input power of the non-standard fan to the standard fan shall be determined per Equation D2 and shall not exceed the max ratio of fan input powers value shown in Table D3. In this section, the word “fan” applies to either an IFM or a non-integrated assembly of a fan, motor, and motor controller.

$$R_{IF} = \frac{P_{IF,non-std}}{P_{IF,std}} \tag{D2}$$

Where:

- R_{IF} = The ratio of the fan input power of the non-standard fan to the fan input power of the standard fan, dimensionless.
- P_{IF,non-std} = The fan input power of the non-standard fan at the compared fan duty point, W.
- P_{IF,std} = The fan input power of the standard fan at the compared fan duty point, W.

Table D3. Values for Evaluating the Fan Input Power for Non-standard Fans					
Method of Fan Input Power Determination			Tolerances for the Non-Standard Fan Test		
Standard Fan	Non-standard Fan	Section	Airflow Tolerance (%)	Pressure Tolerance (in. H ₂ O)	Max Ratio of Fan Input Powers ^{1,2}
Inside the unit	Inside the unit	D3.2.3	-0.5% / +1.0%	+/- 0.05	110%
Outside the unit	Outside the unit	D3.2.4	-0.5% / +1.0%	+/- 0.05	110%
Simulated performance data	Simulated performance data	D3.2.5	N/A ³	N/A ³	105%
Notes:					
<ol style="list-style-type: none"> 1. The ratio of the fan input power of the non-standard fan to the standard fan as shown in Equation D2. 2. The 110% value includes fan testing tolerances. 3. Not applicable 					

D2.2.1 General Requirements. The methods in Section D2.2 can only be applied if the standard and non-standard fans meet all the following requirements:

- 1) At least one of the fans is an IFM such that the motor efficiency cannot be tested using one of the methods in Section D2.1.
- 2) The impeller diameter and number of blades of both fans shall be the same. However, the impeller width is not required to be the same, since for a given airflow and impeller diameter, as pressure rise increases the use of a narrower impeller increases efficiency.
- 3) The maximum ESP at the Manufacturer-specified airflow of a unit with the non-standard fan is greater than that of the same unit with the standard fan.
- 4) If fan arrays are used, all fans and motors shall be identical in any standard or non-standard fan array. When testing outside a unit per Section D2.2.4 or using simulated performance data per Section D2.2.5, only one fan from each fan array needs to be evaluated.

D2.2.2 Determination of the Fan Duty Point. The airflow for the fan duty point is the Manufacturer-specified airflow and the maximum ESP or total static pressure (TSP) shall be determined per the requirements of Section D2.2.3, Section D2.2.4, or Section D2.2.5.

D2.2.3 Requirements if Testing Both Fans Inside a Unit. If both fans are tested inside a unit, all the following requirements shall be met.

- 1) Airflow and ESP shall be determined per the requirements of ASHRAE 37, and airflow shall be corrected to Standard Airflow.
- 2) The indoor fan input power shall be measured per the requirements of Section 5 of ASHRAE 37.
- 3) The unit shall operate with the compressor off during testing.
- 4) If testing the standard and non-standard fans within different units, the two units shall be of identical construction, other than the fan, motor, and motor controller.
- 5) The fan speed of the standard fan shall be set to the highest permitted by the unit controls. The airflow shall be adjusted so that the airflow is within +/- 2% of the Manufacturer-specified airflow. The ESP at that airflow shall be recorded and is the duty point ESP. The fan input power at that duty point shall be recorded.
- 6) The fan speed of the non-standard fan shall be such that the airflow and ESP match the duty point within the tolerances listed in Table D3. The fan input power at that duty point shall be recorded. If the airflow or ESP within the tolerances in Table D3 cannot be matched, conduct testing per the requirements of Section D2.2.6.

D2.2.4 Requirements If Testing Both Fans Outside the Unit. If both fans are tested outside the unit, all the following requirements shall be met.

- 1) Testing shall be performed per the requirements of AMCA 210 or ISO 5801. Performance shall be corrected to Standard Air density per the requirements of AMCA 210.

AHRI STANDARD 1360-2022 (I-P)

- 2) The same standard and non-standard fans distributed in commerce with the basic model shall be used.
- 3) The fan speed of the standard fan shall be set to the highest speed that is permitted by the unit controls. The airflow shall be adjusted so that the airflow is within +/- 2% of the Manufacturer-specified airflow. The TSP at that airflow shall be recorded and is the duty point TSP. The fan input power at that duty point shall be recorded.
- 4) The fan speed of the non-standard fan shall be such that the airflow and TSP match the duty point within the tolerances listed in Table D3. The fan input power at that duty point shall be recorded. If the airflow or ESP within the tolerances in Table D3 cannot be matched, conduct testing per the requirements of Section D2.2.5.

D2.2.5 *Requirements for Using Simulated Performance Data.* If the performance of both fans is determined using simulated performance data, the following requirements shall be met:

- 1) The same standard and non-standard fans sold in commerce with the basic model shall have been tested per the requirements of AMCA 210 or ISO 5801 (this includes tests performed by the fan manufacturer that are used to develop a fan manufacturer's simulated performance software).
- 2) If the tested speeds of one or both fans are not tested at a fan speed that includes the duty point, fan performance shall be determined using the method in Annex I - Wire-to-Air Measurement - Calculation to Other Speeds and Densities (Normative) of AMCA Publication 211. If a fan manufacturer's software is used to simulate performance, the software shall comply with this requirement.
- 3) The TSP and fan input power of the standard fan shall be determined at the Manufacturer-specified airflow and the highest speed that the fan permitted by the unit controls.
- 4) The fan input power of the non-standard fan shall be determined for the same airflow and TSP determined in Section D2.2.5(3).

D2.2.6 *Interpolation to Determine the Fan Power Input of the Non-standard Fan.* For fans tested per the requirements of Section D2.2.3 or Section D2.2.4, if the airflow or pressure tolerances of Table D3 cannot be met, the fan power input shall be determined by interpolation using the following method:

- 1) Test the non-standard fan at a lower fan speed than that required to achieve the duty point. Record the pressure (ESP if testing inside the unit, TSP if testing outside the unit), Standard Airflow, and fan input power for at least three points. At least one point shall be at greater than Manufacturer-specified airflow, and at least one point shall be at less than Manufacturer-specified airflow.
- 2) Test the non-standard fan at a higher fan speed than that required to achieve the duty point. Record the pressure (ESP if testing inside the unit, TSP if testing outside the unit), Standard Airflow, and fan input power for at least three points. At least one point shall be at greater than Manufacturer-specified airflow, and at least one point shall be at less than Manufacturer-specified airflow.
- 3) Determine the fan power input at the duty point by interpolation using the method in Annex I of AMCA Publication 211.

APPENDIX E. METHOD OF TESTING COMPUTER AND DATA PROCESSING ROOM AIR-CONDITIONERS - NORMATIVE

E1 *Purpose.* The purpose of this appendix is to prescribe test procedures used for testing CDPR. Tests shall comply with ASHRAE 127 and ASHRAE 37 as prescribed by this standard, with the following additional requirements.

E2 *Test Unit Location.*

E2.1 *Air-Cooled Split System Equipment.* For testing split systems, the Indoor Unit shall be in the indoor test room (meaning the test chamber maintained at the air conditions specified for return indoor air). The outdoor unit shall be located based on the type of Connections to Condenser or Condensing Unit.

E2.1.1 *Free Air Discharge Condensers.* Free Air Discharge Condensers shall be in the outdoor test room (meaning the test chamber maintained at the air conditions specified for outdoor ambient air), unless the Manufacturer's Installation Instructions indicate that the Free Air Discharge Condenser is intended for indoor installation, meaning that the Free Air Discharge Condenser shall be in the indoor test room.

E2.1.2 *Ducted Condensers.* Ducted Condensers shall be in the indoor test room and set up for testing with condenser ducting per Section D6.2.

E2.2 *Air-Cooled Single Packaged Equipment.* For testing single package units, the unit shall be in the outdoor test room unless the Manufacturer's Installation Instructions indicate that the unit is intended for indoor installation, meaning that the unit shall be in the indoor test room.

E2.3 *Water-cooled and Glycol-cooled Equipment.* The unit (including both units for split systems) shall be in the indoor test room.

E3 *Test Method for Upflow Ducted Units in Chambers of Limited Height.*

E3.1 *General.* If there is limited height in the test chamber, such that a vertical outlet duct with pressure taps for measuring external static pressure (ESP) compliant with Section 6.4.2.1 or Section 6.4.3 (for units with multiple fans) of ASHRAE 37 cannot be installed, refer to Figure E1 of this appendix for test duct requirements if the up-flow ducted system has a single fan outlet connection, and refer to Figure E2 if the up-flow system has multiple fan outlet connections. For units with a centrifugal fan or fans with horizontal axis and vertical discharge, the elbow or elbows redirecting air from vertical to horizontal direction shall bend in the direction of motion at the top the fan wheel. If the unit is shipped with a discharge plenum, do not test with the plenum.

E3.2 *Units with Multiple Indoor Blowers.* If either of the following provisions apply, test with a single outlet duct as shown in Figure E1:

- 1) the Manufacturer Installation Instructions indicate the unit is intended to be installed with a single discharge duct; or
- 2) the unit has a single outlet duct connection flange.

For other units with multiple blowers, attach a duct with a 90° elbow for each fan outlet connection to redirect airflow horizontally. External static pressure in each duct shall be measured as specified in Section 6.4.2 of ASHRAE 37. Combine all air ducts into a single horizontal "common duct" downstream of the static pressure taps. Refer to Figure E2 for test setup details. If needed to equalize the static pressure in each duct, an adjustable restrictor shall be in the plane where each individual duct enters the common duct section.

E3.3 *Turning Vanes.* Calculate the discharge velocity using Equation E1:

$$V = \frac{\text{Rated airflow [CFM]}}{\text{Total discharge area [ft}^2\text{]}} \quad \text{E1}$$

AHRI STANDARD 1360-2022 (I-P)

For units with discharge velocity greater than 800 feet per minute (fpm), turning vanes shall be used in the 90° elbow, as specified in Figure E1 and Figure E2. For units with discharge velocity less than or equal to 800 feet per minute (fpm), turning vanes shall not be used in the 90° elbow.

E3.4 Vertical Section. As shown in Figure E1 and Figure E2, for up-flow systems tested in a limited height setup, a vertical straight duct shall be installed between each fan discharge of the tested unit and the unit’s corresponding 90° elbow. The length of this straight duct shall be calculated using Equation E2:

$$L = 1.25 * \sqrt{A \times B} \tag{E2}$$

Where,

- A is the width of unit duct flange or fan discharge;
- B is the depth of unit duct flange or fan discharge.

If this length of the vertical straight duct cannot be achieved, use a length as close as possible. See Section 5.1.

E3.5. ESP Adjustment. Use the equations in Table E1 to calculate the adjusted minimum ESP requirement by subtracting ΔESP from the ESP requirement specified in Section E5.1. Round the calculated value of ΔESP to the nearest 0.01 in. H₂O.

Table E1 ESP Adjustment		
Discharge Velocity	Bend Type	ESP Adjustment Equation¹
V > 800 fpm	Turning vanes, as specified in Figure E1 or E2	$\Delta ESP = 0.26 * \rho \left(\frac{V}{1097} \right)^2$
V ≤ 800 fpm	Without turning vanes	$\Delta ESP = 1.34 * \rho \left(\frac{V}{1097} \right)^2$
Note: 1. ρ is the air density at the airflow test measurement station, lb/ft ³		

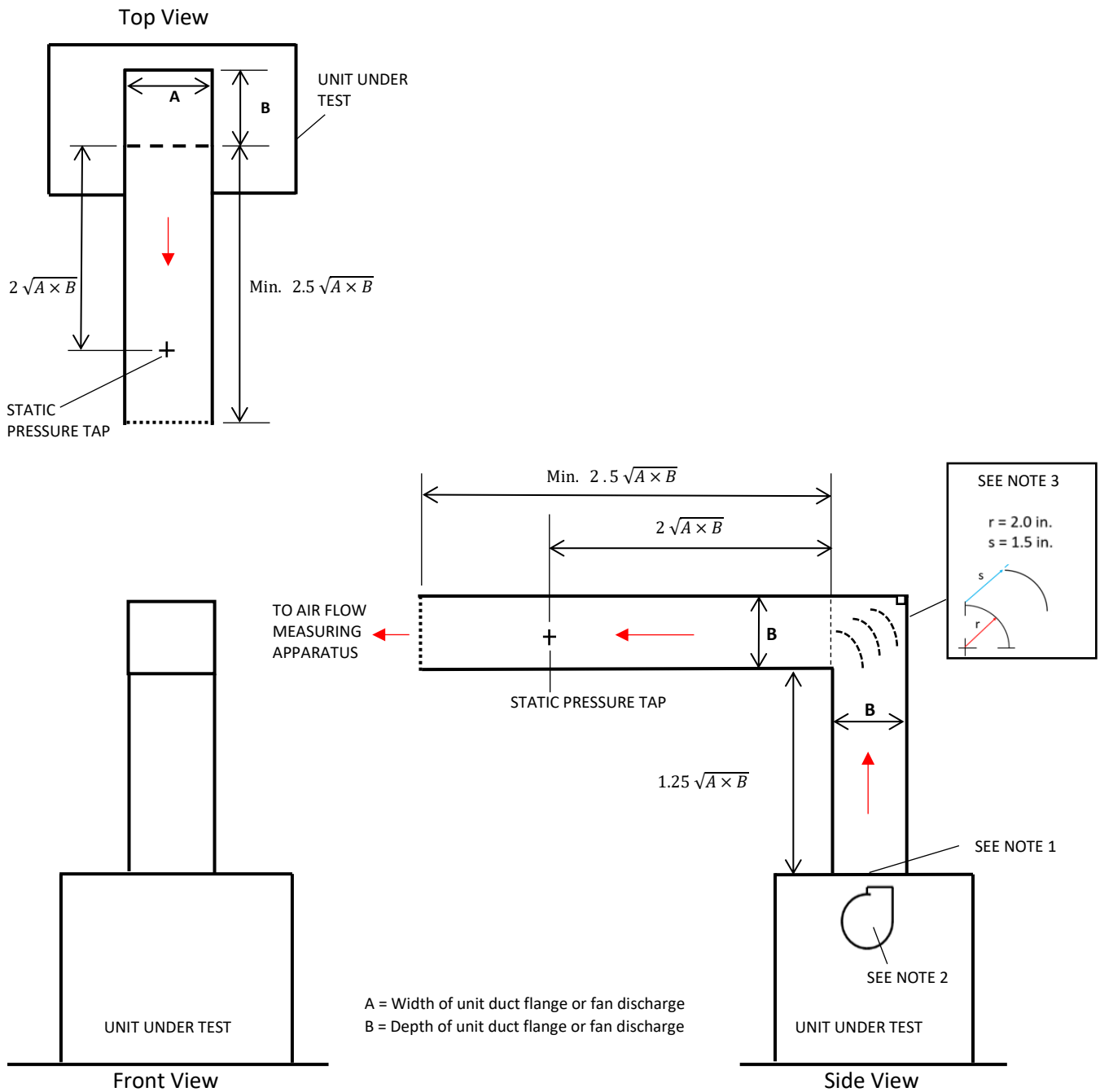

Figure E1. Test Duct Setup for Up-flow Unit with Single Fan Outlet Connection in Limited Height Test Chamber

Requirements for Figure E1 include:

1. Test duct shall fit over provided duct flange. If a flange is not provided, vertical duct section shall match dimensions of blower section.
2. For units with a centrifugal fan or fans with horizontal axis and vertical discharge, the elbow or elbows redirecting air from vertical to horizontal direction shall bend in the direction of motion at the top of the fan wheel.
3. If turning vanes are required as per section E2.3, the 90° elbow shall have single thickness turning vanes inside, with vane radius r and vane distance s .

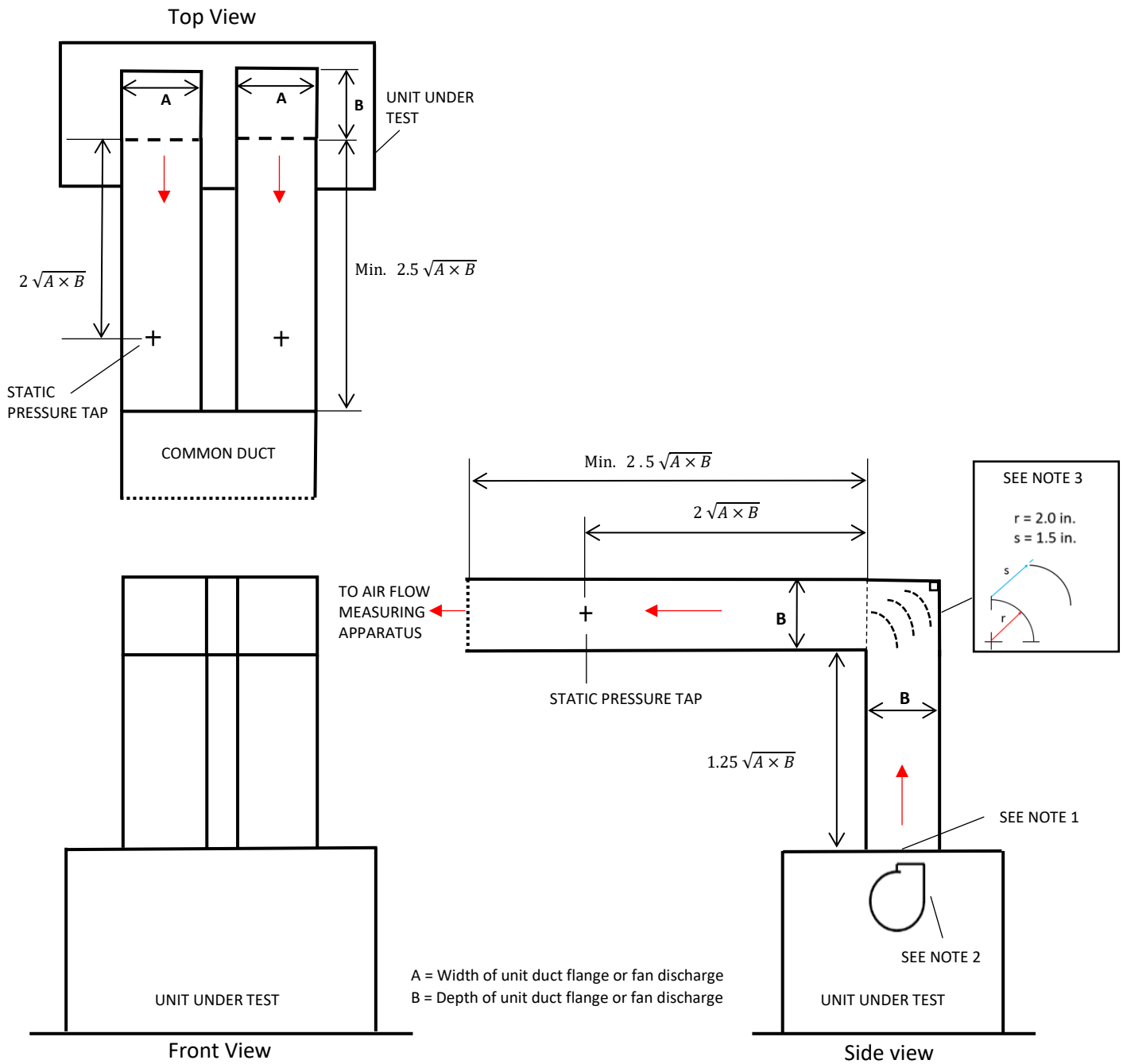

Figure E2. Test Duct Setup for Up-flow Unit with Multiple Fan Outlet Connections in Limited Height Test Chamber

Requirements for Figure E2:

1. Test duct shall fit over provided duct flange. If a flange is not provided, vertical duct section shall match dimensions of blower section.
2. For units with a centrifugal fan or fans with horizontal axis and vertical discharge, the elbow or elbows redirecting air from vertical to horizontal direction shall bend in the direction of motion at the top of the fan wheel.
3. If turning vanes are required as per Section E2.3, the 90° elbow shall have single thickness turning vanes inside, with vane radius r and vane distance s .

AHRI STANDARD 1360-2022 (I-P)

E4 *Test Unit Duct Installation Requirements.* ASHRAE 37 duct requirements shall be followed. Furthermore, the test apparatus including the interconnecting ductwork shall be insulated to have a minimum R-value of 13 ft²·°F·hr/Btu. Duct losses can be calculated using conduction factors, inside air and outside ambient temperature difference, and the total duct surface area between the unit and the temperature measurement location. Ducts that are exposed to multiple ambient temperatures shall be divided into zones and each zone calculated separately.

E5 *Test Setup and Airflow for Indoor Units.*

E5.1 *External Static Pressure Target Values* Test using the applicable minimum external static pressure (ESP) specified in Table 5.

E5.2 *Airflow Target Value.*

Use the Manufacturer-specified airflow. If an airflow is not specified, use the airflow that results from operating at the minimum ESP requirement using the as-shipped fan control settings.

All airflow rates, including those used for determining capacity, shall be Standard Airflow rates expressed in terms of Standard Air.

E5.3 *Indoor Air External Static Pressure and Airflow Tolerances and Set-Up*

E5.3.1 *General.* Set indoor airflow while operating at the standard rating conditions specified in Section 6.1. After setting the airflow, adjustments cannot be made to the fan control settings during the test.

E5.3.2 *Tolerances.* All tolerances for airflow and ESP specified in this section for setting airflow and ESP are condition tolerances that apply for the test. Specifically, the average value of a parameter measured over the course of the test shall vary from the target value by not more than the condition tolerance. Operating tolerances for ESP and nozzle pressure drop are specified in Table 7.

E5.3.3. *Non-Ducted Units.*

Operate the unit under the specified test conditions using the Manufacturer-specified fan control settings. If Manufacturer-specified fan control settings are not provided, use the as-shipped fan control settings. Adjust the airflow-measuring apparatus to maintain ESP within - 0 / + 0.05 in H₂O of 0.0 in H₂O and to maintain the airflow within ± 3% of the Manufacturer specified airflow. If an airflow is not specified, there is not a condition tolerance for airflow.

If ESP or airflow are not within tolerance when using the Manufacturer-specified fan control settings, adjust the fan control settings to maintain both ESP and airflow within tolerance. If ESP or airflow are higher than the tolerance range at the lowest fan control setting (including lowest fan speed) or lower than the tolerance range at the maximum fan control setting (including highest fan speed), adjust the airflow-measuring apparatus to maintain ESP within tolerance and operate with an airflow as close as possible to the Manufacturer-specified value.

For two adjacent fan control settings, if the lower setting is too low (meaning ESP or airflow are lower than the tolerance range) and the higher setting is too high (meaning ESP or airflow are higher than the tolerance range), use the higher fan control setting. At this higher fan control setting, adjust the airflow-measuring apparatus to maintain ESP within tolerance.

If an airflow is used that deviates from the Manufacturer-specified airflow by more than 3% because the airflow and ESP requirements cannot be simultaneously met at any fan control settings, there is not a test condition tolerance for airflow.

E5.3.4. *Ducted Units.*

E5.3.4.1. *Units with a Manufacturer-specified Airflow.*

AHRI STANDARD 1360-2022 (I-P)

Operate the unit under the specified test conditions using the Manufacturer-specified fan control settings. If Manufacturer-specified fan control settings are not provided, use the as-shipped fan control settings. Adjust the airflow-measuring apparatus to maintain ESP within $-0 / +0.05$ in H_2O of the requirement specified in Table 5 and to maintain the airflow within $\pm 3\%$ of the Manufacturer-specified airflow.

If ESP or airflow are higher than the tolerance range, adjust the fan control settings (including lower fan speed) to maintain both ESP and airflow within tolerance. If ESP or airflow are higher than the tolerance range at the lowest fan control setting (including lowest fan speed), adjust the airflow-measuring apparatus to maintain airflow within tolerance and operate with the lowest ESP that meets the minimum requirement specified in Table 5.

If ESP or airflow are lower than the tolerance range, adjust the fan control settings (including higher fan speed) to maintain both ESP and airflow within tolerance. If ESP or airflow are lower than the tolerance range at the maximum fan control setting (including highest fan speed), adjust the airflow-measuring apparatus to maintain ESP within tolerance and operate with an airflow as close as possible to the Manufacturer-specified value.

For two adjacent fan control settings, if the lower setting is too low (meaning ESP or airflow are lower than the tolerance range) and the higher setting is too high (meaning ESP or airflow are higher than the tolerance range), use the higher fan control setting. At this higher fan control setting, adjust the airflow-measuring apparatus to maintain airflow within tolerance and operate with an ESP as close as possible to the minimum requirement specified in Table 5.

If the ESP measured after setting airflow exceeds the minimum ESP requirement by more than 0.05 in H_2O (because the ESP and airflow requirements cannot be simultaneously met), a test condition tolerance for ESP does not exist. If an airflow less than 97% of the Manufacturer-specified airflow is used (because the airflow and ESP requirements cannot be simultaneously met), there is not a test condition tolerance for airflow.

E5.3.4.2. Units without a Manufacturer-specified Airflow. Operate the unit under the specified test conditions using the Manufacturer-specified fan control settings. If Manufacturer-specified fan control settings are not provided, use the as-shipped fan control settings. Adjust the airflow-measuring apparatus to meet the applicable ESP requirement specified in Table 5 with a condition tolerance of $-0 / +0.05$ in H_2O . After setting the airflow, adjustments cannot be made to the test unit fan drive or fan speed control system during the test.

E6 *Test Setup and Airflow for Air cooled Condensers.*

E6.1 *Outdoor Airflow Rate for Air-Cooled Units with Free Air Discharge Condensers.*

All Standard Ratings shall be determined at the outdoor airflow rate obtained without condenser ducting. Where the fan drive is non-adjustable, the Standard Ratings shall be determined at the outdoor airflow rate inherent in the equipment. For adjustable speed fans, the outdoor fan speed shall be set as specified in the Manufacturer's Installation Instructions or as determined by automatic controls. Once established, changes affecting outdoor airflow shall not be made unless automatically adjusted by unit controls. Outdoor airflow rate does not need to be measured unless using the outdoor air enthalpy method per Section E7.3.

E6.2 *Outdoor Airflow Rate and External Static Pressure for Air-Cooled Units with Ducted Condensers.*

Install the unit with outdoor coil ductwork and ESP measurements made in accordance with Section 6.4 and Section 6.5 of ASHRAE 37 and Manufacturer's Installation Instructions as applicable. If Manufacturer's Installation Instructions provide guidance for setting outdoor airflow (such as outdoor fan control settings), set the outdoor airflow per Manufacturer's Installation Instructions, while maintaining the outdoor air ESP within $-0.00 / +0.05$ in H_2O of the applicable ESP in Table 6. If Manufacturer's Installation Instructions do not provide guidance for setting outdoor airflow, test using the as-shipped outdoor fan setting while maintaining the outdoor air ESP within $-0.00 / +0.05$ in H_2O of the applicable ESP. If the outdoor air ESP cannot be maintained within $-0.00 / +0.05$ in H_2O of the applicable ESP at the Manufacturer-specified or as-shipped fan setting (as applicable), operate with a fan setting as close as possible to the target fan setting (meaning Manufacturer-specified or as-shipped) that allows for meeting this outdoor air ESP requirement.

E6.2.1 *Setting Non-zero Outdoor Air ESP.* Set non-zero outdoor air ESP by either

- 1) symmetrically restricting the outlet of the outdoor air outlet duct downstream of the minimum duct length specified in Section 6.4.2.1 of ASHRAE 37 (meaning, at least 2.5 times the mean geometric cross-sectional dimension from the equipment outlet) or;
- 2) adjusting the exhaust fan of the outdoor air-side test apparatus (if used for testing).

E6.2.2 *Outdoor Air ESP Tolerance.* The outdoor air ESP tolerance of $-0.00 / + 0.05$ in H_2O is a condition tolerance that applies throughout the test. Specifically, the average value of the outdoor air ESP measured over the course of the test shall not vary from the target value by more than the condition tolerance. An operating tolerance for ESP is specified in Table 7.

E7 *Test Methods for Capacity Measurement.*

E7.1 *Primary Capacity Measurement.* Use the indoor air enthalpy method specified in Section 7.3 of ASHRAE 37 as the primary method for capacity measurement.

For the following equipment, secondary measurements are not required:

- 1) single package evaporatively-cooled equipment with rated Cooling Capacity greater than or equal to 135,000 Btu/h
- 2) Air-cooled single package equipment with outdoor airflow rates (either Manufacturer-specified or determined with testing) above 9000 scfm

For all other equipment, use one of the applicable Group B methods specified in Table 1 of ASHRAE 37 as a secondary method for capacity measurement.

Conduct measurements for all equipment in accordance with the provisions in Section 7.3, Section 7.4, Section 7.5, and Section 7.6 of ASHRAE 37 that are applicable to the selected test method. For the outdoor air enthalpy method, the provisions in Section E7.5 take precedence over the provisions in Section 7.3 of ASHRAE 37.

E7.2 *Agreement Between Primary and Secondary Capacity Measurements.* The Net Total Cooling Capacity values measured with the secondary capacity measurement methods as prescribed in Section E7.2 shall match within $\pm 6\%$ of the primary capacity measurement method test results.

E7.3 *Outdoor Air Enthalpy Method.*

E7.3.1 *Units with Free Air Discharge Condensers* When using the outdoor air enthalpy method as the secondary method for capacity measurement, first conduct a test without the outdoor air-side test apparatus connected to the outdoor unit and then attach the outdoor air-side test apparatus and conduct a test with the apparatus connected to the outdoor unit. Use measurements from testing without the outdoor air-side test apparatus connected (meaning indoor air enthalpy method capacity measurements and power input) as the applicable measurements for determination of efficiency metrics, provided the specified conditions are met.

E7.3.1.1. *Free Outdoor Air Test.* For the free outdoor air test, connect the indoor air-side test apparatus to the indoor coil; do not connect the outdoor air-side test apparatus. Allow the test room reconditioning apparatus and the unit being tested to operate for at least one hour.

After attaining steady-state operations conditions, measure the following quantities at equal intervals that span five minutes or less:

- 1) The evaporator and condenser temperatures or pressures
- 2) Parameters required according to the indoor air enthalpy method (as specified in Section 7.3 of ASHRAE 37)

Continue these measurements until the applicable test tolerances are satisfied for a thirty-minute period (such as, seven consecutive five-minute samples).

AHRI STANDARD 1360-2022 (I-P)

Evaporator and Condenser Measurements. To measure evaporator and condenser pressures, solder a thermocouple onto a return bend located at the midpoints of each coil or at points not affected by vapor superheat or liquid subcooling. Alternatively, if the test unit is not sensitive to the refrigerant charge, install pressure gauges to the access valves or to ports created from tapping into the suction and discharge lines according to Section 7.4.2 and Section 8.2.5 of ASHRAE 37. The alternative approach shall be used when testing a unit charged with a zeotropic refrigerant having a temperature glide more than 1°F greater than the specified test conditions.

For the free outdoor air test to constitute a valid test for determination of efficiency metrics, the following conditions shall be met:

- 1) For the ducted outdoor test, the capacities determined using the outdoor air enthalpy method shall agree within 6% of the capacities determined using the indoor air enthalpy method.
- 2) The capacity determined using the indoor air enthalpy method from the ducted outdoor air test shall agree within 2% of the capacity determined using the indoor air enthalpy method from the free outdoor air test.

E7.4.1.2. *Ducted Outdoor Air Test.*

After collecting thirty minutes of steady-state data during the free outdoor air test, connect the outdoor air-side test apparatus to the unit for the ducted outdoor air test. Adjust the exhaust fan of the outdoor air-side test apparatus until averages for the evaporator and condenser temperatures, or the saturated temperatures corresponding to the measured pressures, agree within $\pm 0.5^\circ\text{F}$ of the averages achieved during the free outdoor air test. Collect thirty minutes of steady-state data where the applicable test tolerances are satisfied.

During the ducted outdoor air test, at intervals of five minutes or less, measure the parameters required according to the indoor air enthalpy method and the outdoor air enthalpy method for the prescribed thirty minutes.

Calculate cooling capacity based on outdoor air enthalpy measurements as specified in Section 7.3.3.2 and Section 7.3.3.3 of ASHRAE 37. Adjust the outdoor-side capacity according to Section 7.3.3.4 of ASHRAE 37 to account for line losses when testing split systems. Use the outdoor airflow rate as measured during the ducted outdoor air test to calculate capacity for checking the agreement with the capacity calculated using the indoor air enthalpy method during the ducted outdoor test.

E7.4.2 *Units with Ducted Condensers.* With the outdoor air-side test apparatus connected to the unit, collect thirty minutes of steady-state data where the applicable test tolerances (including for outdoor air ESP, as specified in Section E6.2) are satisfied.

At intervals of five minutes or less, measure the parameters required according to the indoor air enthalpy method and the outdoor air enthalpy method for the prescribed 30 minutes.

Calculate cooling capacity based on outdoor air enthalpy measurements as specified in Section 7.3.3.2 and Section 7.3.3.3 of ASHRAE 37. Adjust the outdoor-side capacity according to Section 7.3.3.4 of ASHRAE 37 to account for line losses when testing split systems. Use the outdoor airflow rate as measured during the outdoor airflow measurement test to calculate capacity for checking the agreement with the capacity calculated using the indoor air enthalpy method during the outdoor airflow measurement test.

Use measurements from testing with the outdoor air-side test apparatus connected (meaning indoor air enthalpy method capacity measurements and power input) as the applicable measurements for determination of efficiency metrics, provided the capacities determined using the outdoor air enthalpy method agree within 6% of the capacities determined using the indoor air enthalpy method.

E8. *Test Set-up for Non-Ducted Units.*

E8.1 *Free Air Test.* A preliminary free air test shall be conducted prior to connecting a plenum (as specified in Section E7.3.1.1), ducting, and indoor air-side test apparatus to the unit. Airflow rate shall be set in accordance with Section E5. Operating tolerances defined in Table 7 (as applicable) shall be met for at least ten minutes, except for

AHRI STANDARD 1360-2022 (I-P)

tolerances for outdoor leaving air dry-bulb temperature, outdoor leaving air wet-bulb temperature, indoor leaving air dry-bulb temperature, indoor leaving air wet-bulb temperature, external static pressure, and nozzle pressure drop. Record the average indoor fan power and average refrigerant temperature at the midpoint of the return bend of the indoor coil. After connecting the plenum, duct, and indoor air-side test apparatus to the unit, adjust the fan of the indoor air-side test apparatus attached to the duct as necessary to achieve the required plenum pressure of zero ESP with a tolerance of $-0 / + 0.05$ in H_2O . The fan settings used for the preliminary free indoor air test shall remain unchanged throughout the full-load cooling test. Confirm that indoor fan power measured with the indoor air-side test apparatus connected is within 2% of the average values measured for the free air test. Confirm that refrigerant temperature at the midpoint of the return bend of the indoor coil is within $0.5^\circ F$ of the average values measured for the free air test. Increase plenum size if necessary to match the measured values within these tolerances.

E8.2 *Inlet Plenum.* An inlet plenum for non-ducted units shall not be used.

E8.3 *Outlet Plenum and Duct Requirements.* For non-ducted units, a plenum (enlarged duct box) shall be installed between the duct and the Indoor Unit(s), as depicted in Figure E3. The plenum shall have a cross-sectional area at least two times the area of the Indoor Unit(s) combined outlet. For all outlets, the plenum shall extend for a distance of at least 3.5 times the square root of the cross-sectional area of the units combined outlet prior to any duct transitions, elbows, or Air Sampling Tree used for air condition measurement.

If used, elbows connected to the end of the plenum shall have a centerline radius equal to at least 1.5 times the duct width in the radial direction or have turning vanes. Air velocities calculated as measured volume flow divided by duct or plenum cross-sectional area shall not exceed 250 feet per minute inside the plenum and 500 feet per minute in the connecting duct at its connection to the plenum. Figure E3 shows a plenum construction example.

Manifolded static pressure taps shall be installed in the plenum in at least four locations spaced uniformly around the plenum per Section 6.5 of ASHRAE 37. The static pressure taps shall be 2.8 times the square root of the cross-sectional area of the combined outlets. Static pressure in the plenum shall be maintained within 0.05 in H_2O of ambient pressure.

Air Sampling Trees used for temperature measurement shall be placed in the duct between the airflow measurement apparatus and the minimum required plenum length.

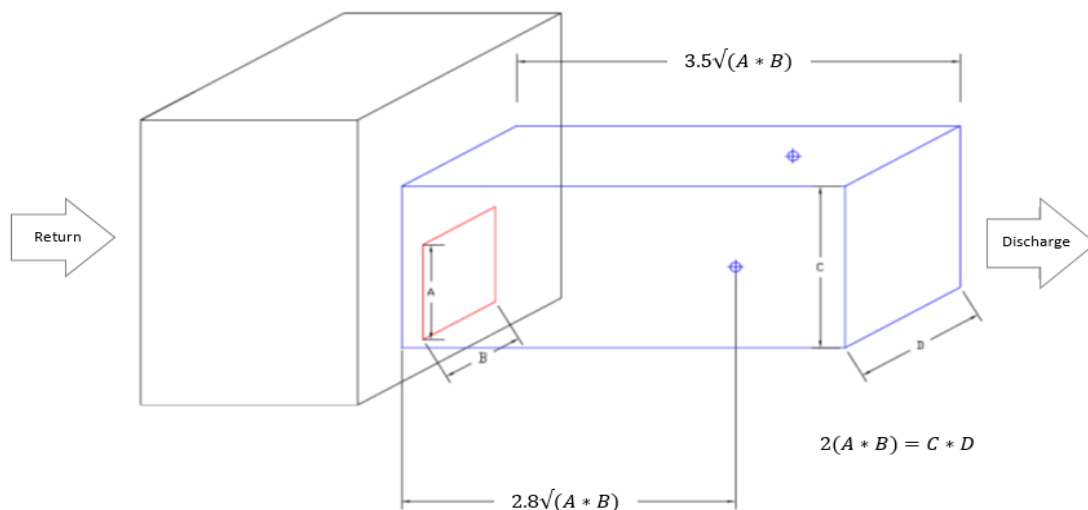

Figure E3. Example Test Setup for Outlet Plenum for Free Air Discharge Units

AHRI STANDARD 1360-2022 (I-P)

E9 *Refrigerant Flow Measurement Device.* Refrigerant flow measurement device(s) shall be either elevated at least two feet from the test chamber floor or placed upon insulating material having a total thermal resistance (R-value) of at least $12 \text{ hr}\cdot\text{ft}^2 \cdot ^\circ\text{F}/\text{Btu}$, and extending at least one foot laterally beyond each side of the device(s)' exposed surfaces.

E10. *Minimum Data Collection Requirements.* Either power (in W) or integrated power (in W·h) shall be measured. Units with modulating compressors require either an integrated power measurement or power measurements recorded at intervals not longer than one second.

APPENDIX F. INDOOR AND OUTDOOR AIR CONDITION MEASUREMENT - NORMATIVE

This appendix includes modifications to the test stand setup and instrumentation as defined in ASHRAE 37 and shall be used to be compliant with this standard.

F1 *General.* Measure the indoor and outdoor air entering dry-bulb temperature and water vapor content conditions that are required to be controlled for the test per the requirements in Section F2 and Section F3 using the Air Sampling Devices described below. When using the indoor air enthalpy method to measure equipment capacity, measure indoor air leaving dry-bulb temperature and water vapor content. When using the outdoor air enthalpy method to measure equipment capacity, measure outdoor air leaving dry-bulb temperature and water vapor content. For measuring the indoor and outdoor air leaving dry-bulb temperature and water vapor content conditions, follow the requirements in Section F4. Make these measurements as described in the following sections. Maintain test operating and test condition tolerances and uniformity requirements as described in Section F2.7.

F2 *Outdoor Air Entering Conditions.* For cooling tests of Air-cooled equipment that uses condensate obtained from the evaporator to enhance condenser cooling, measure the water vapor content as provided in Section F2.2.

F2.1 *Temperature Measurements.* Measure temperatures in accordance with ASHRAE 41.1 and follow the requirements of Table F1. The specified accuracies shall apply to the full instrument systems including read-out devices. When using a grid of individual thermocouples rather than a thermopile, follow the thermopile temperature requirements of Table F1.

When measuring dry-bulb temperature for sampled air within the sampled air conduit rather than with the psychrometer as discussed in Section F2.4, use a temperature sensor and instrument system, including read-out devices, with accuracy of $\leq \pm 0.2^\circ\text{F}$ and display resolution of $\leq 0.1^\circ\text{F}$.

To meet the thermopile temperature requirements of Table F1, the thermocouple wire shall have special limits of error and all thermocouple junctions in a thermopile shall be made from the same spool of wire; thermopile junctions are wired in parallel.

Table F1. Temperature Measurement Requirements		
Measurement	Accuracy, °F	Display Resolution, °F
Dry-bulb and Wet-bulb Temperatures ¹	$\leq \pm 0.2$	≤ 0.1
Thermopile Temperature	$\leq \pm 1.0$	≤ 0.1
Note: 1. The accuracy specified is for the temperature indicating device and does not reflect the operation of the Aspirating Psychrometer.		

F2.2 *Psychrometer or Hygrometer Requirements.* If measurement of water vapor is required, use an Aspirating Psychrometer or a Dew-point Hygrometer.

F2.2.1 *Aspirating Psychrometer.* The Aspirating Psychrometer consists of a flow section and a fan to draw air through the flow section and measures an average value of the sampled air stream. The flow section shall be equipped with two dry-bulb temperature probe connections. One shall be used for the facility temperature measurement and the other shall be accessible to confirm this measurement using an additional or a third-party’s temperature sensor probe. For applications where the humidity is required, the flow section shall be equipped with two wet-bulb temperature probe connection zones. One shall be used for the facility wet-bulb measurement and the other shall be provided to confirm the wet-bulb measurement using an additional or a third-party’s wet-bulb sensor probe. The Aspirating Psychrometer shall include a fan that can either be adjusted manually or automatically to maintain the required velocity of 1000 ± 200 fpm across the sensors.

AHRI STANDARD 1360-2022 (I-P)

An example configuration for the Aspirating Psychrometer is shown in Figure F1.

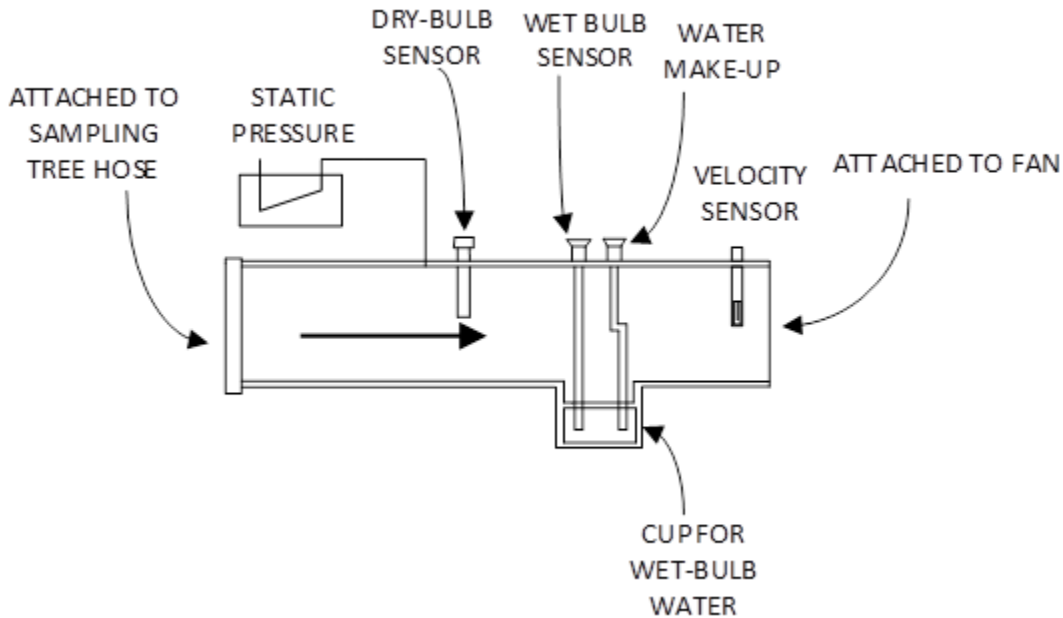

Figure F1. Aspirating Psychrometer

F2.2.2 Dew-point Hygrometer. Measure dew point temperature using a Dew-point Hygrometer as specified in Section 4, Section 5, Section 6, Section 7.1, and Section 7.4 of ASHRAE 41.6 with an accuracy of within $\pm 0.4^{\circ}\text{F}$. Use a dry-bulb temperature sensor within the sampled air conduit and locate the Dew-point Hygrometer downstream of the dry-bulb temperature sensor.

F2.3 Air Sampling Tree Requirements. The Air Sampling Tree is intended to draw a uniform sample of the airflow entering the Air-cooled condenser section. An example configuration for the sampling tree is shown in Figure F2 for a tree with overall dimensions of 4 ft by 4 ft sample.

Note: Other sizes and rectangular shapes can be used and should be scaled accordingly if the aspect ratio (width to height) of not greater than two to one is maintained.

The unit shall be constructed of stainless steel, plastic or other durable materials and shall have a main flow trunk tube with a series of branch tubes connected to the trunk tube. The branch tubes shall have spaced holes, sized to provide equal airflow through all the holes by increasing the hole size as you move further from the trunk tube to account for the static pressure regain effect in the branch and trunk tubes. A minimum hole density of six holes per square foot of area to be sampled is required. The minimum average velocity through the sampling tree holes shall be 2.5 ft/sec as determined by evaluating the sum of the open area of the holes as compared to the flow area in the Aspirating Psychrometer. The assembly shall have a tubular connection to allow a flexible tube to be connected to the sampling tree and to the Aspirating Psychrometer.

The outdoor inlet Air Sampling Tree shall be equipped with a thermocouple thermopile grid or individual thermocouples to measure the average temperature of the airflow over the Air Sampling Tree. Angled or wrap-around Air Sampling Trees shall have a thermocouple thermopile grid or a grid of individual thermocouples to separately measure the average temperature for each plane (meaning each set of co-planar air sampling holes) of the Air Sampling Tree. The Air Sampling Trees shall be placed within 6-12 in from the unit to minimize the risk of damage to the unit while ensuring that the Air Sampling Trees are measuring the air going into the unit rather than the room air around the unit. Sampling holes shall not pull in the discharge air leaving the outdoor section of the unit under test. Any sampler holes directly exposed to the outdoor coil discharge air shall be blocked to prevent sampling. Blocking holes does not necessarily prevent thermal transfer on Air Sampling Tree tubes, therefore portions of the Air Sampling Tree tubes directly exposed to the outdoor coil discharge air shall be thermally shielded with a material with an R-value of 0.7 to 1.06 $\text{m}^2\cdot\text{K}/\text{W}$ (4 to 6 $\text{ft}^2\cdot^{\circ}\text{F}\cdot\text{hr}/\text{Btu}$).

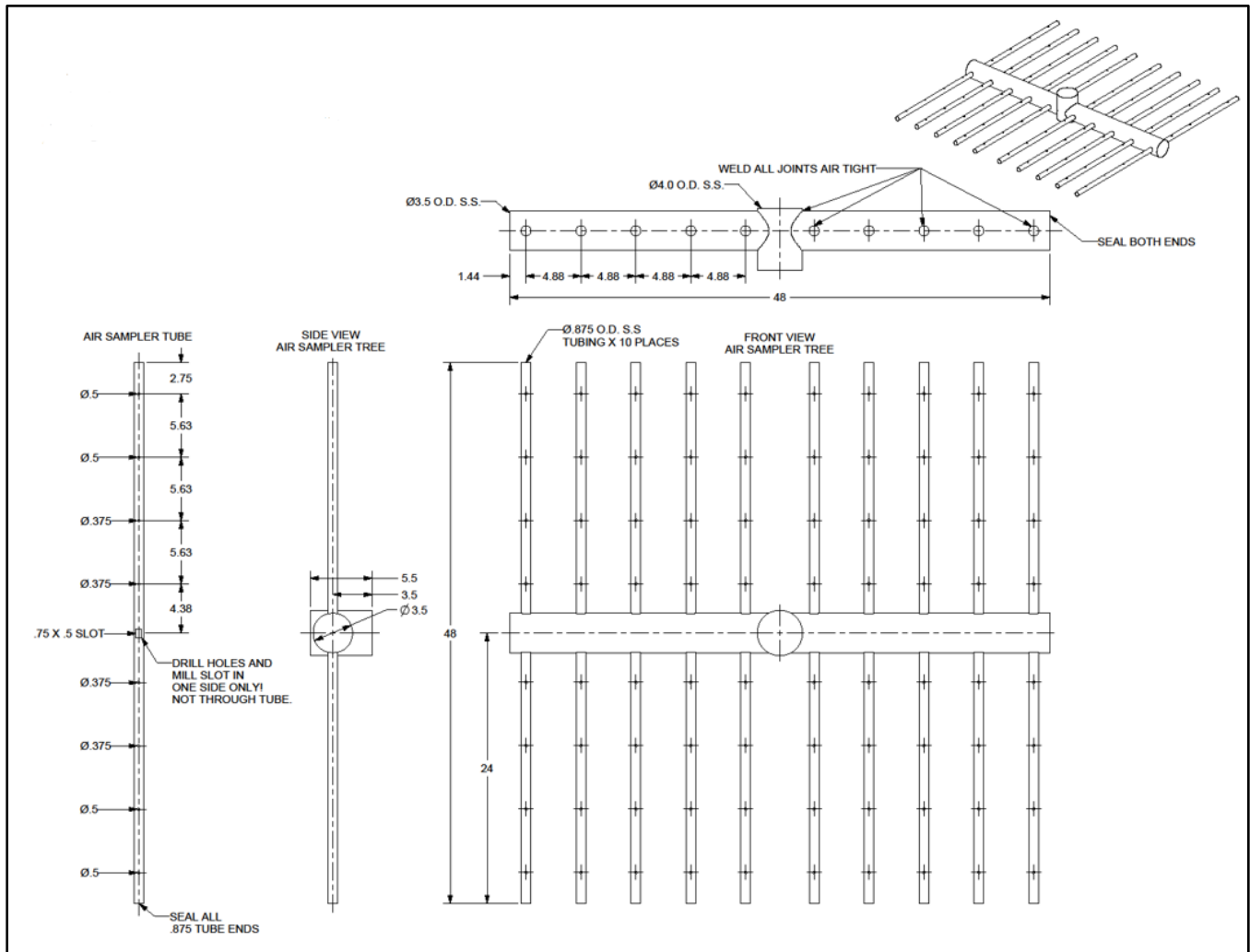

Figure F2. Example Air Sampling Tree

Notes:

1. The 0.75 in X 0.50 in slots referenced in Figure F2 are cut into the branches of the sampling tree and are located inside of the trunk of the sampling tree. The slots are placed to allow air to be pulled into the main trunk from each of the branches.
2. All exterior welds shall be ground smooth and flush.
3. All pieces shall be level, plumb and square.
4. All pieces shall be cleaned, chamfered and deburred.

F2.3.1 Test Setup Description.

The nominal face area of the airflow shall be divided into equal area sampling rectangles with aspect ratios not greater than two to one. Each rectangular area shall have one Air Sampling Tree. The nominal face area shall include all regions where air enters through the unit.

Note: The nominal face area may extend beyond the condenser coil depending on coil configuration and orientation.

An example of measurement rectangles and the required number of air sampling trees is shown in Figure F3.

AHRI STANDARD 1360-2022 (I-P)

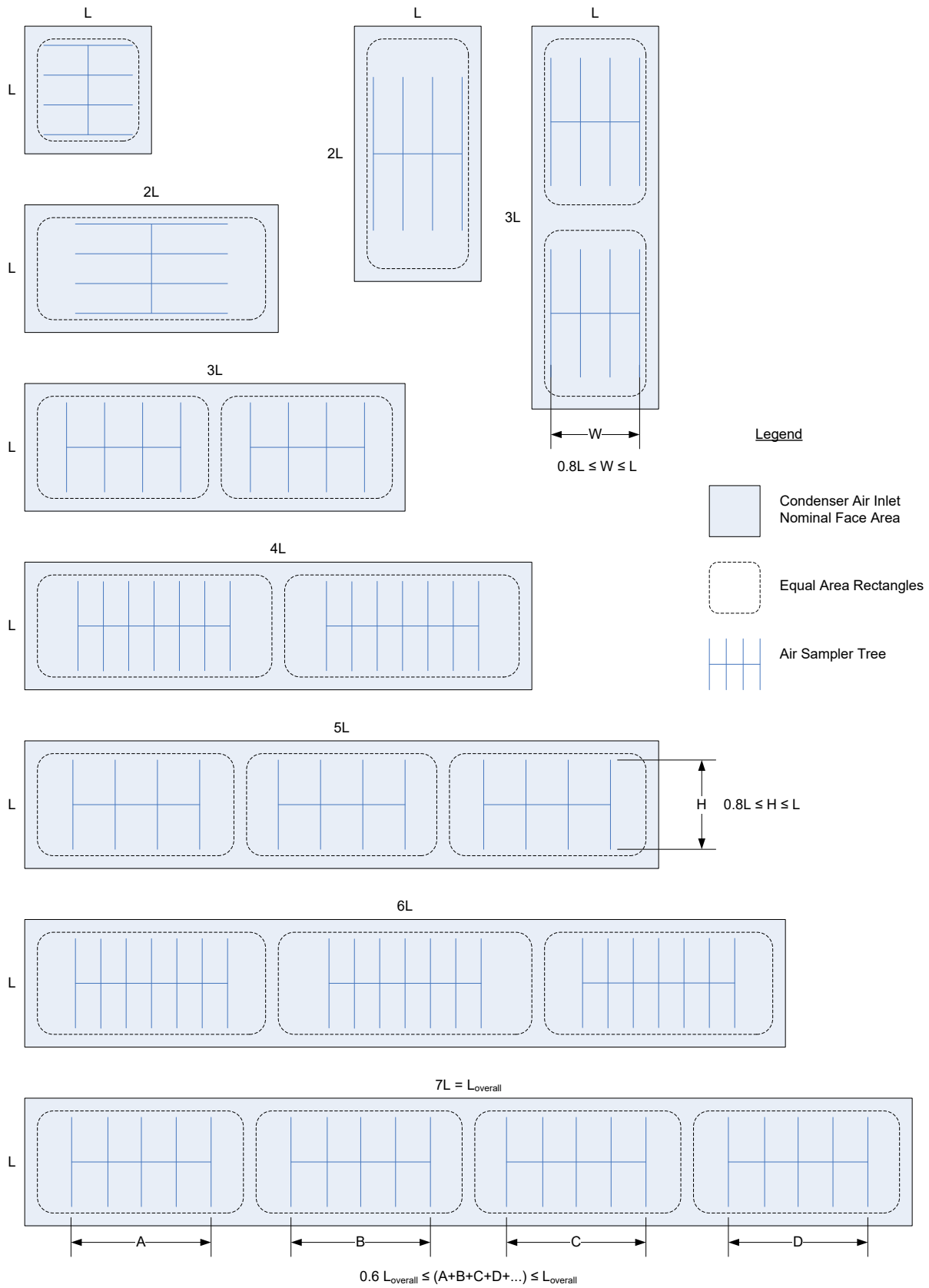

Figure F3. Determination of Measurement Rectangles and Required Number of Air Sampling Trees

AHRI STANDARD 1360-2022 (I-P)

An example test setup is shown in Figure F4.

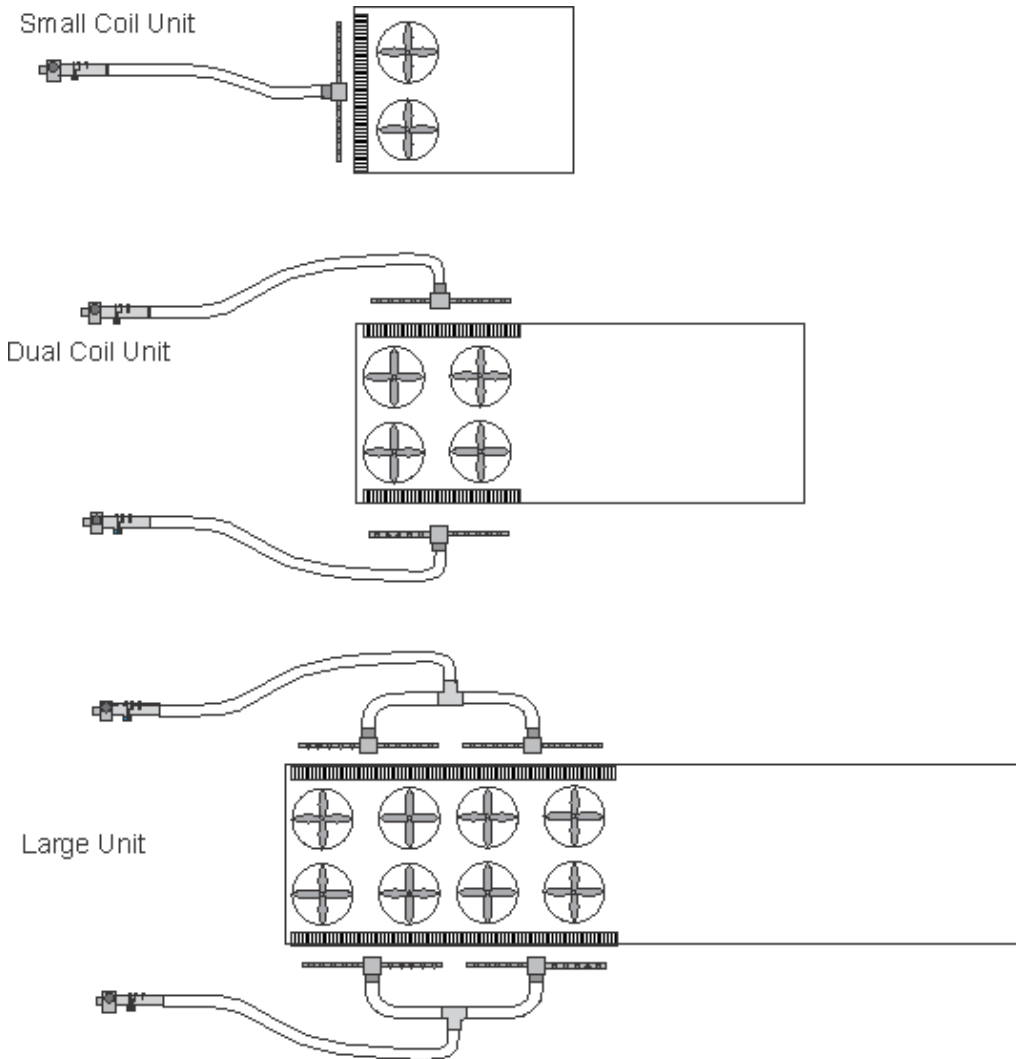

Figure F4. Example Test Setup Configurations

A minimum of one Aspirating Psychrometer or Dew-point Hygrometer per side of a unit shall be used except for units with three or more sides. For units with three or more sides, two sampling Aspirating Psychrometers/Dew-point Hygrometers shall be used but shall require a separate Air Sampling Tree for the third side. For units that have air entering the sides and the bottom of the unit, additional Air Sampling Trees shall be used. For units that require more than eight Air Sampling Trees, install a thermocouple thermopile grid or individual thermocouples on each rectangular area where an Air Sampling Tree is not installed.

The Air Sampling Trees shall be located at the geometric center of each rectangle; either horizontal or vertical orientation of the branches is correct. The sampling trees shall cover at least 80% of the height and 60% of the width of the air entrance to the unit (for long horizontal Coils) or shall cover at least 80% of the width and 60% of the height of the air entrance (for tall vertical Coils). If the sampling trees extend beyond the face of the air entrance area, block all branch inlet holes that extend beyond that area. The sample trees shall be located six to twelve inches from the inlet face of the unit. Refer to Figure F3 for examples of how an increasing number of Air Sampling Trees are required for longer condenser Coils.

A maximum of four Air Sampling Trees shall be connected to each Aspirating Psychrometer/Dew-point Hygrometer. The Air Sampling Trees shall be connected to the Aspirating Psychrometer/Dew-point Hygrometer using flexible tubing that is insulated and routed to prevent heat transfer to the air stream. To proportionately divide the flow stream for multiple Air Sampling Trees for a given Aspirating Psychrometer/Dew-point Hygrometer, the flexible tubing shall

AHRI STANDARD 1360-2022 (I-P)

be of equal lengths for each Air Sampling Tree. Refer to Figure F4 to see examples of Air Sampling Tree and Aspirating Psychrometer/Dew-point Hygrometer setups.

If using more than one Air Sampling Tree, all Air Sampling Trees shall be of the same size and have the same number of inlet holes.

Draw air through the Air Sampling Tree using the fans of the psychrometer(s) or, if not using psychrometers, fans that allow adjustment of airflow through the Air Sampling Tree inlet holes as specified in Section F2.3. Return the fan discharge air to the room where the system draws the outdoor coil intake air.

F2.4 *Dry-bulb Temperature Measurement.* Measure dry-bulb temperatures using the psychrometer dry-bulb sensors, or, if not using psychrometers, use dry-bulb temperature sensors with accuracy as described in Section F2.1. Measure the dry-bulb temperature within the conduit Air Sampling Tree at a location between the Air Sampling Tree exit to the conduit and the air sampler fan. When a fan draws air through more than one Air Sampling Tree, the dry-bulb temperature can be measured separately for each Air Sampling Tree or for the combined set of Air Sampling Tree flows. If dry-bulb temperature is measured at the Air Sampling Tree exit to the conduit, the use of a thermocouple thermopile grid or a grid of individual thermocouples for duplicate measurement of dry-bulb temperature is not required—instead use the air-sampling-tree-exit measurement when checking temperature uniformity.

F2.5 *Wet-Bulb or Dew Point Temperature Measurement to Determine Air Water Vapor Content.* Measure wet-bulb temperatures using one or more psychrometers or measure dew point temperature using one or more hygrometers. If using hygrometers, measure dew point temperature within the conduit conducting Air Sampling Tree air to the air-sampling fan at a location downstream of the dry-bulb temperature measurement. When a fan draws air through more than one Air Sampling Tree, the dew point temperature can be measured separately for each Air Sampling Tree or for the combined set of Air Sampling Tree flows.

When more than one Air Sampling Tree feeds a single water vapor content measurement instrument, measure relative humidity as required in Section F2.7 to allow assessment of water vapor content uniformity.

F2.6 *Monitoring and Adjustment for Air Sampling Tree Conduit Temperature Change and Pressure Drop.* If dry-bulb temperature is measured at a distance from the Air Sampling Tree exits, determine average conduit temperature change as the difference in temperature between the remote dry-bulb temperature and the average of thermopiles or thermocouple measurements of all Air Sampling Trees collecting air that is measured by the remote dry-bulb temperature sensor. If this difference is greater than 0.5°F, measure dry-bulb temperature at the exit of each Air Sampling Tree (as described in Section F2.4), and use these additional sensors to determine average indoor entering air dry-bulb temperature.

Measure gauge pressure at the sensor location of any instrument measuring water vapor content. If the pressure differs from room pressure by more than 2 in H₂O, use this gauge pressure measurement to adjust the atmospheric pressure used to calculate the humidity ratio (in units of pounds of moisture per pound of dry air) at the measurement location.

If either the 0.5°F temperature difference threshold or the 2 in H₂O pressure difference threshold are exceeded, use a two-step process to calculate adjusted air properties (such as wet-bulb temperature or enthalpy) for the one or more affected Air Sampling Trees. First, calculate the moisture level (pounds water vapor per pound dry air) at the humidity measurement location(s) using either the psychrometer dry-bulb and wet-bulb temperature measurements or the hygrometer dew point measurement, using for either approach the adjusted pressure, if the adjusted pressure differs from the room atmospheric pressure by 2 in H₂O or more. Then calculate the air properties for the Air Sampling Tree location based on the moisture level, the room atmospheric pressure, and the dry-bulb temperature at the Air Sampling Tree location. If the Air Sampling Tree fan or psychrometer serves more than one Air Sampling Tree, and the 0.5°F threshold is exceeded, the dry-bulb temperature used in this calculation shall be the average of the Air Sampling Tree exit measurements. For multiple Air Sampling Trees, if humidity is measured using multiple hygrometers, the moisture level used in this calculation shall be the average of the calculated moisture levels calculated in the first step.

F2.7 *Temperature Uniformity.* The room conditioning equipment airflow shall be set such that recirculation of condenser discharged air is circumvented except as can naturally occur from the equipment. To check for the recirculation of condenser discharged air back into the condenser coil(s) the following method shall be used: Multiple individual reading thermocouples (at least one per Air Sampling Tree location) shall be installed around the unit air discharge perimeter below the plane of condenser fan exhaust and just above the top of the condenser coil(s). These thermocouples shall not indicate a temperature difference greater than 5.0°F from the average inlet air. Air distribution at the test facility, at the point of supply to the unit,

AHRI STANDARD 1360-2022 (I-P)

shall be reviewed to determine if the air distribution requires remediation prior to beginning testing.

Mixing fans can be used to maintain air distribution in the test room. If used, mixing fans shall be oriented to be pointed away from the air intake so that the mixing fan exhaust direction is at an angle of 90°-270° to the air entrance to the condenser air inlet. Pay particular attention to prevent recirculation of condenser fan exhaust air back through the unit.

When not using psychrometers, the psychrometer dry-bulb temperature measurement of Table F2 refers to either the dry-bulb temperature measurement in a single common air conduit serving one or more Air Sampling Trees or the average of the dry-bulb temperature measurements made separately for each of the Air Sampling Trees served by a single Air Sampling Tree fan. The wet-bulb temperature refers to calculated wet-bulb temperatures based on dew point measurements.

Adjust measurements if required by Section F2.6 prior to checking uniformity.

The 1.5°F dry-bulb temperature tolerance in Table F2 between the Air Sampling Tree thermopile (thermocouple) measurements and psychrometer measurements only applies when more than one Air Sampling Tree serves a given psychrometer (see note 2 to Table F2).

The uniformity requirements apply to test period averages rather than instantaneous measurements.

When water vapor content measurement is required, confirm uniformity of wet-bulb temperature variation among Air Sampling Trees. When more than one Air Sampling Tree feeds a single Aspirating Psychrometer or dew point sensor, measure relative humidity of the air external to each of these Air Sampling Trees using a relative humidity sensor having $\pm 2\%$ relative humidity accuracy located within three inches of geometric center of the Air Sampling Tree. Calculate wet-bulb temperature for these Air Sampling Trees using the relative humidity measurement and the dry-bulb temperature measurements from either the thermopiles (thermocouple grid averages), or the measurements at the Air Sampling Tree exits. The maximum allowable difference between the calculated wet-bulb temperature for any Air Sampling Tree and the average wet-bulb temperature for all Air Sampling Trees used to measure outdoor entering air conditions is 1.00°F.

A valid test shall meet the criteria for air distribution and control of air temperature as shown in Table F2.

Table F2. Uniformity Criteria for Outdoor Air Temperature and Humidity Distribution		
Uniformity Criterion ¹	Purpose	Maximum Variation, °F
Deviation from the mean air dry-bulb temperature to the air dry-bulb temperature at any individual temperature measurement station [†]	Uniform dry-bulb temperature distribution	± 2
Difference between dry-bulb temperature measured with air sampler tree thermopile and with Aspirating Psychrometer ²	Uniform dry-bulb temperature distribution	± 1.5
Deviation of local air sampler wet-bulb temperatures and the mean wet-bulb temperature	Uniform humidity distribution	± 1
Deviation from the mean wet-bulb temperature and the individual temperature measurement stations	Uniform humidity distribution	± 1
<p>Notes:</p> <ol style="list-style-type: none"> 1. The uniformity requirements apply to test period averages for each parameter rather than instantaneous measurements. Each measurement station represents a single Aspirating Psychrometer. The mean temperature is the mean of temperatures measures from all measurement stations. 2. Applies when multiple air samplers are connected to a single psychrometer or conduit dry-bulb temperature sensor. If the average of the thermopile measurements differs from the psychrometer or conduit dry-bulb temperature sensor measurement by more than 0.5°F, use air-sampler exit dry-bulb temperature sensors. For this case, the uniformity requirement is based on comparison of each of the air-sampler exit measurements with the average of these measurements. 3. 		

The wet-bulb temperature measurement shall be used only for outdoor entering air for evaporatively-cooled units.

F3 *Indoor Coil Entering Air Conditions.* Follow the requirements for outdoor coil entering air conditions as described in Section C2, except for the following.

- 1) Both dry-bulb temperature and water vapor content measurements shall be completed for all tests.
- 2) Sampled air shall be returned to the room where the system draws the indoor coil entering air. If the loop air enthalpy test method specified in Section 6.1.2 of ASHRAE 37 is used, the sampled air shall be returned upstream of the Air Sampling Tree in the loop duct between the airflow-measuring apparatus and the room conditioning apparatus or to the airflow-measuring apparatus between the nozzles and the fan.
- 3) The temperature uniformity requirements discussed in Section F2.7 do not apply if a single Air Sampling Tree is used.
- 4) If air is sampled within a duct, the Air Sampling Tree shall be installed with the rectangle defined by the Air Sampling Tree inlet holes oriented parallel with and centered in the duct cross section—this rectangle shall have dimensions that are at least 75% of the duct’s respective dimensions.
- 5) If an inlet plenum is not connected to the air inlet during testing (including for a non-ducted Indoor Unit), set up Air Sampling Tree(s) as described Section F2.3.1.

F4 *Indoor Coil Leaving Air and Outdoor Coil Leaving Air Conditions.* Follow the requirements for measurement of outdoor coil entering air conditions as described in Section F2, except for the following.

The temperature uniformity requirements discussed in Section F2.7 do not apply.

Both dry-bulb temperature and water vapor content measurements are required for indoor coil leaving air for all tests and for outdoor coil leaving air for all tests using the outdoor air enthalpy method.

Air in the duct leaving the coil that is drawn into the Air Sampling Tree for measurement shall be returned to the duct just

AHRI STANDARD 1360-2022 (I-P)

downstream of the Air Sampling Tree and upstream of the airflow-measuring apparatus.

For a coil with a blow-through fan (meaning, where the fan is located upstream of the coil), use a grid of individual thermocouples rather than a thermopile on the Air Sampling Tree, even if air-sampler-exit dry-bulb temperature measurement instruments are installed. If the difference between the maximum time-averaged thermocouple measurement and the minimum time-averaged thermocouple measurement is greater than 1.5°F, install mixing devices such as those described in Section 5.3.2 and Section 5.3.3 of ASHRAE 41.1 to reduce the maximum temperature spread to less than 1.5°F.

The Air Sampling Tree (used within the duct transferring air to the airflow-measuring apparatus) shall be installed with the rectangle defined by the Air Sampling Tree inlet holes oriented parallel with and centered in the duct cross section. This rectangle shall have dimensions that are at least 75% of the duct's respective dimensions.

APPENDIX G. INTEGRATED NET SENSIBLE COP RATING - INFORMATIVE

G1 *Purpose.* The purpose of this appendix is to define the Integrated Net Sensible COP (iNSenCOP) rating. A long-term goal is for iNSenCOP is to replace NSenCOP after a testable means has been standardized.

G2 *Background.* Data Centers require CDPR to operate over a wide range of outdoor ambient conditions while providing cooling for ITE that is independent of outdoor temperature conditions, therefore these units are specifically designed to provide continuous year-round cooling at a constant indoor cooling load. The iNSenCOP rating allows for a single standardized value to simplify unit to unit year-round cooling energy efficiency comparisons.

G3 *Test Limitations.* The B, C, and D tests in Table G1 are required to operate at the Standard Rating Condition (see Tables 2 and 3) cooling load, because the data center cooling load is constant year-round. Because the compressor is oversized, and economization means can be included for tests B, C, and D test conditions within the tolerances of the current test method can be difficult to maintain.

G4 *Calculation.* iNSenCOP is calculated based on the NSenCOP ratings from standard Rating Conditions (Tests A) and Reduced Ambient Rating Conditions (Tests B, C, and D). A weighted average of each of these ratings is used based on the normalized values of A = 13.4%, B = 27.1%, C = 38.1%, and D = 21.5%. See Equation G1.

$$iNSenCOP = (C_1 \cdot \text{Test A NSenCOP}) + (C_2 \cdot \text{Test B NSenCOP}) + (C_3 \cdot \text{Test C NSenCOP}) + (C_4 \cdot \text{Test D NSenCOP}) \tag{G1}$$

Where:

- C₁ = 0.134
- C₂ = 0.271
- C₃ = 0.381
- C₄ = 0.215

iNSenCOP = Integrated Sensible Coefficient of Performance

NSenCOP = Net Sensible Coefficient of Performance

Standard Rating Conditions (Test A) are shown in Table 2 and Table 3. Reduced ambient ratings (Tests B, C, and D) are shown in Table G1. Refer to Section 6 for additional rating requirements not defined in this Appendix. For Water-cooled, Glycol-cooled, and chilled water units, include allowances for pumping and fan power in the total unit power used to calculate NSenCOP at each test conditions, as specified in Section 6.3.3, Section 6.3.4, and Section 6.3.5.

Table G1: Cooling Fluid Standard and Reduced Ambient Rating Conditions					
Cooling Fluid	Fluid Condition	Standard and Reduced Ambient Rating Condition Tests			
		A	B	C	D
Air-cooled units	Entering outdoor ambient dry-bulb temperature, °F	95.0	80.0	65.0	40.0
Water-cooled units	Entering water temperature, °F	83.0	70.0	55.0	45.0
	Leaving water temperature, °F	N/A			
	Water flow rate, gpm	Max = Test A ¹			
Glycol-cooled units	Entering glycol temperature, °F	104.0	85.0	65.0	35.0
	Leaving glycol temperature, °F	N/A			
	Glycol flow rate, gpm	Max = Test A ¹			
	Glycol solution concentration	40% Propylene Glycol by Volume			
Notes:					
1. Test setup is as in standard Rating Conditions (Test A), but the head pressure control can lower the flow rate.					

APPENDIX H. EXAMPLE OF DETERMINATION OF FAN AND MOTOR EFFICIENCY FOR NON-STANDARD INTEGRATED INDOOR FAN AND MOTORS - INFORMATIVE

H1 *Background.* An individual model with a non-standard indoor fan motor can be rated within the same basic model as an individual model with a standard fan motor if the former individual model is otherwise identical to the latter individual model, and if the non-standard fan motor has the same or higher relative efficiency as the standard fan motor (determined per Section D2.1). However, for certain direct-drive indoor fans, the motor and fan cannot be separated or are not rated separately, or both. For such fans, the efficiency of the fan and motor combination, rather than the efficiency of the fan motor alone, is used to compare performance of the standard and non-standard fans, per the approach provided in Section D2.2. This method is provided for cases where either or both standard or non-standard fans are integrated fans and motors (IFM). This appendix includes an example to help in the application of the procedures specified in Section D2.2 to determine the relative efficiency of the standard and non-standard fan and motor combinations.

H2 *The Concept.* The standard and non-standard fans are operated at the same airflow and pressure rise, referred to as the duty point. Section D2.2 requires that the electrical power required to run the non-standard fan be not more than 110% of that of the standard fan if both fans are tested at the duty points. The 110% includes the allowance for variance due to testing inaccuracies and biases. Alternatively, the fan performance may be compared without testing by using the fan manufacturer’s software. In that case, because there is no testing variation to account for, the ratio of fan powers is limited to 105%. Figure H1 is an example of output from a fan manufacturer’s software where there two non-standard fans.

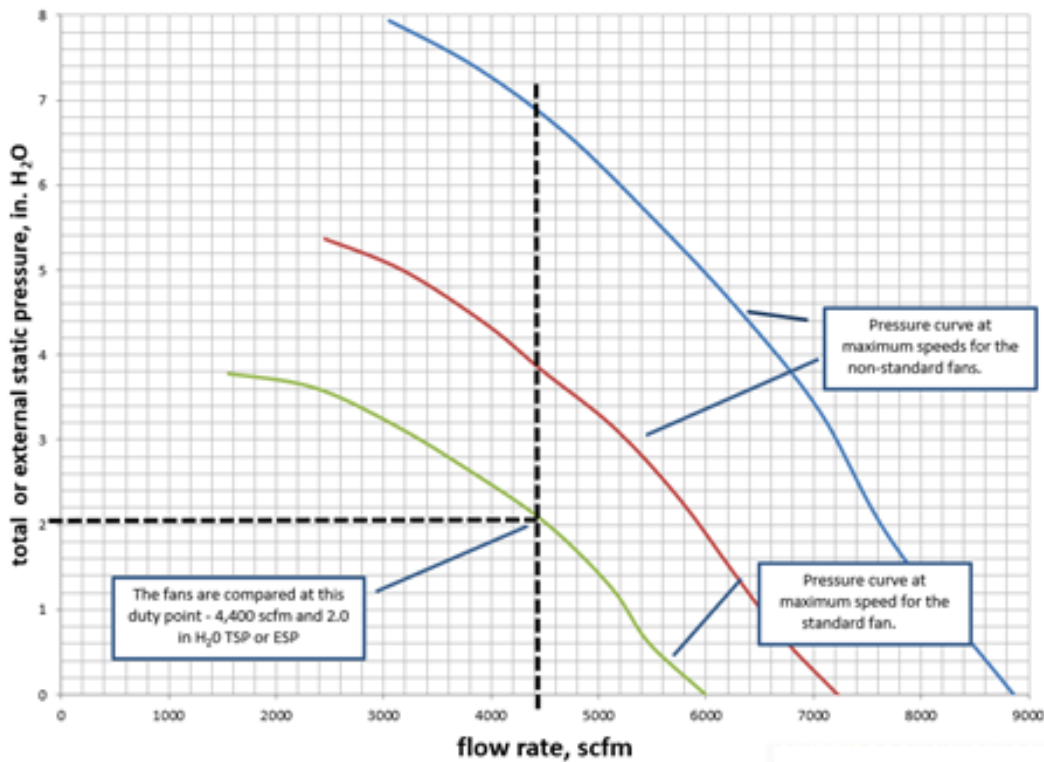

Figure H1. Illustration of the Duty Point Where Standard and Non-standard Fan Input Power is Compared

H3 *Testing Both Fans Inside a Unit.* The Manufacturer-specified airflow for the unit is 4400 scfm. The standard fan is set to the highest speed, and the ESP is adjusted so that the airflow is 4402 scfm, that is within 2% of the Manufacturer-specified airflow. An ESP of 2.0 in. H₂O is measured. The fan power of 2100 W is recorded. Then, a unit with a non-standard fan is tested with the goal of operating at the same airflow and ESP where the standard fan is tested. Section D2.2 requires the tested airflow and ESP of the standard fan to be within the tolerances shown in Table D3 when compared to the non-standard fan and the measured fan input power of the non-standard fan be not more than 2310 W (2100 W X 110%). Laboratory variance is accounted for in the 110% allowance.

AHRI STANDARD 1360-2022 (I-P)

H4 *Example – Comparison Using Software Based on Testing by Either the Requirements of AMCA 210 or ISO 5801.* The fan manufacturer can provide software that calculates the fan input power at any airflow and total static pressure within the fan's operating envelope. If the underlying tests are performed using either AMCA 210 or ISO 5801, and performance for non-tested speeds is interpolated per the requirements of Annex I of AMCA 211 (in the software calculations), the manufacturer's software may be used instead of testing.

For this example, using the graph above, the maximum speed of the standard fan is 1800 RPM, and the green line represents the performance at that speed. The TSP of the operating point is equal to the value of the green line at 4400 scfm. This shows a total static pressure of 2.0 in. H₂O. The software shows that fan input power of the standard fan at this operating point is 2000 W. The fan input power of the other fans is determined at the same duty point. For both non-standard fans, the fan input power determined cannot exceed 2100 W (2000 W X 105%).