

Note: This guideline has been withdrawn because the information is outside the scope of AHRI. The information is readily available from other sources including manufacturers' installation instructions. The information is not referenced in any international codes or standards.

# Guidelines For Roof Mounted Outdoor Air-Conditioner Installations



Air-Conditioning, Heating,  
and Refrigeration Institute

Sheet Metal and  
Air-Conditioning Contractors  
National Association



**GUIDELINE B-1997**

Withdrawn from publication 16 February 2025

## ACKNOWLEDGEMENT

These guidelines for Roof Mounted Outdoor Air-Conditioner Installations were prepared by the of the Air-Conditioning, Heating, and Refrigeration Institute (AHRI) and the Sheet Metal and Air-Conditioning Contractors National Association (SMACNA).

Therefore, thanks are in order for efforts by the technical staffs of each organization and the committees within each organization for their review and comments to finalize this document.

### **Note:**

This guideline has been withdrawn because the information is outside the scope of AHRI. The information is readily available from other sources including manufacturers' installation instructions. The information is not referenced in any international codes or standards.

This guideline supersedes ARI Guideline B-1986.

---

# GUIDELINES FOR ROOF MOUNTED OUTDOOR AIR-CONDITIONER INSTALLATIONS

Prepared by:

**Air-Conditioning, Heating, and  
Refrigeration Institute**

2111 Wilson Boulevard, Suite 500,  
Arlington, VA 22201

**Sheet Metal and Air-Conditioning  
Contractors National Association**

4201 Lafayette Center Dr., Chantilly, VA 22021

June 1997

This guideline has been withdrawn because the information is outside the scope of AHRI. The information is readily available from other sources including manufacturers' installation instructions. The information is not referenced in any international codes or standards.

## TABLE OF CONTENTS

	<b>Page</b>
Preface .....	1
Section A—Curb Criteria for Roof Mounted Equipment.....	2
Section B—Stand Mounting Criteria .....	3
Section C—Unit Installation .....	9
Section D—External Connections	
D-1—Exterior Duct Closures and Connection to Equipment .....	11
D-2—Electrical .....	15
D-3—Piping .....	16
D-4—Drains .....	19
Section E—General Instructions	
E-1—Checklist for Equipment Installation and Service .....	20
E-2—Flashings .....	21

## **PREFACE**

This guideline has been withdrawn because the information is outside the scope of AHRI. The information is readily available from other sources including manufacturers' installation instructions. The information is not referenced in any international codes or standards.

This document contains guidelines for the installation of roof mounted outdoor air-conditioner equipment as developed and agreed upon by the Air-Conditioning, Heating, & Refrigeration Institute (AHRI) and Air-Conditioning Contractor's National Association, Inc. (SMACNA). The purpose of these Guidelines which cover curb and roof penetrations and sealings is to set forth good construction practices. The Guidelines are just that—guidelines—and are not standards, warranties or certifications.

The information contained in these Guidelines should serve as a supplement to the unit manufacturer's specific installation instructions. The precise steps to be taken with respect to a specific curb, roof penetration or sealing may vary according to particular circumstances, job conditions and manufacturer's specifications. In all cases, the necessary installation work should be done by and under the supervision of skilled and qualified personnel.

These Guidelines cover instructions on the interface between the roof and the location at which the unit, piping, electrical wiring or sheet metal ductwork pass through the roof. For more detailed design information, see the SMACNA Architectural Sheet Metal Manual, HVAC Duct Construction Standards, and the National Electrical Code. These documents were the source for many of the recommendations made in these Guidelines. No changes in these AHRI - SMACNA Guidelines shall be made without the approval of AHRI and SMACNA.

## Section A

---

### **Curb Criteria for Roof Mounted Equipment**

---

1. The top of the curb should be level after installation.
2. The curb and the equipment should be structurally capable of supporting intended loads and should be so designed that no penetration for drains, power lines, etc., will occur through the roof flashing.
3. The curb should be furnished with a wood nailer which provides a minimum of 3-½ inches of nailing surface, mounted at the top of the curb, to permit mechanical attachment of the flashing material.
4. Caution should be used when considering the use of wood that has been treated with an oil borne preservative for wood nailers. The oil that is used in many lumber treatments can act as a solvent on roofing materials and can cause bitumen drippage. When wood nailers constructed of wood that has been treated with an oil borne preservative are used, a barrier of rosin-sized sheathing paper or similar material should be placed between the built-up roof membrane and the nailer.
5. The curb should provide a minimum clearance of 10 inches between the top of the finished roof surface and the top of the wood nailer, continuous around the curb perimeter. In no case should the curb be less than 14 inches in height. (See *Figure 6.*)
6. If the curb does not include a counterflashing receiver, a separate counterflashing receiver should be installed prior to the installation of the equipment. All receivers should be of watertight construction.
7. The metal counterflashing may extend down over the base flashing so that no composition material is exposed, thereby reducing the danger to foot abuse. (See *Figure 6.*)

## Section B

---

### Stand Mounting Criteria

---

Some mechanical equipment installations require that roofing materials be installed or maintained beneath them. Table 1 presents guidelines for the clearances necessary to accomplish this purpose. Units which allow access from the sides may permit reduction of these values.

Typical methods for flashing of unit supports are shown in Figures 1 through 5.

**Table 1**  
**WORKING CLEARANCES**

<b>Width of Equipment</b>	<b>Height Above Roof Surface</b>
<b>Up To 24"</b>	<b>14"</b>
<b>25" To 36"</b>	<b>18"</b>
<b>37" To 48"</b>	<b>24"</b>
<b>49" To 60"</b>	<b>30'</b>
<b>61" And Wider</b>	<b>48"</b>

**Figure 1**  
**Mechanical Equipment Stand**

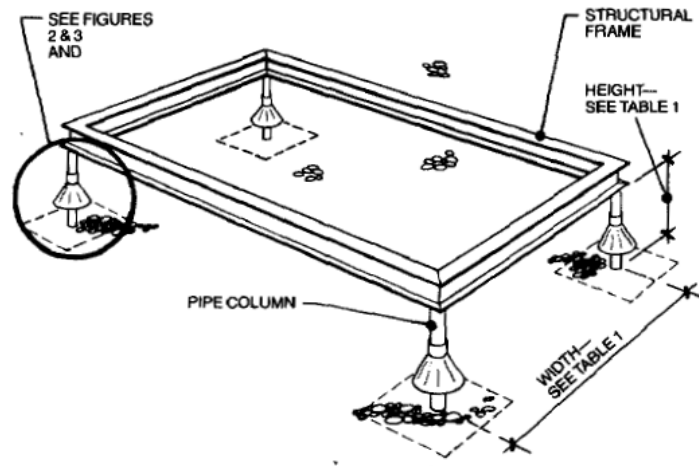



Figure 2

---

**Insulated Steel Deck Frame**

---

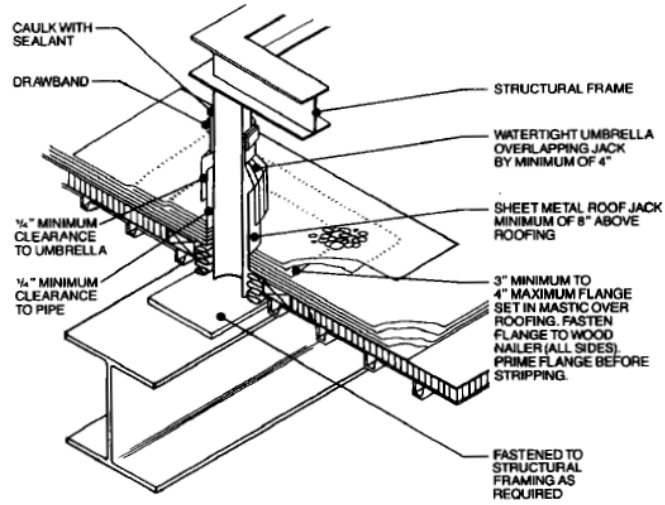
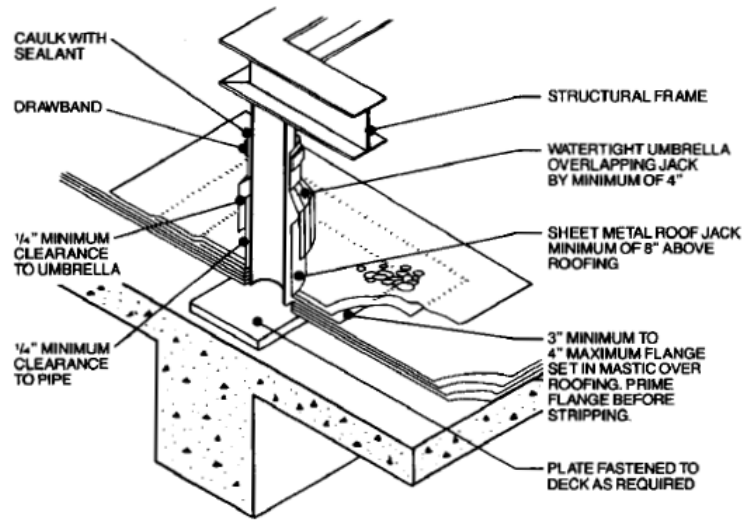

Figure 3

---

Concrete Deck And Frame

---



# Figure 4

---

## Equipment Support

---

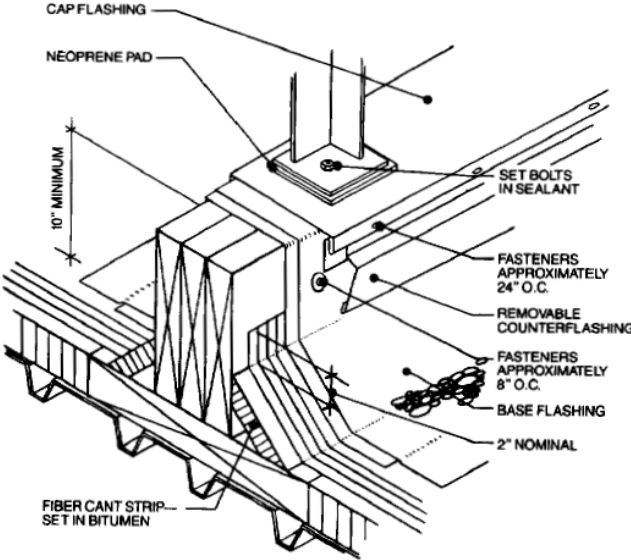

NOTE: SEE TABLE 1 FOR RECOMMENDED HEIGHTS FOR STAND ABOVE ROOF SURFACE

Figure 5

Flashing Structural Member Through Roof Deck

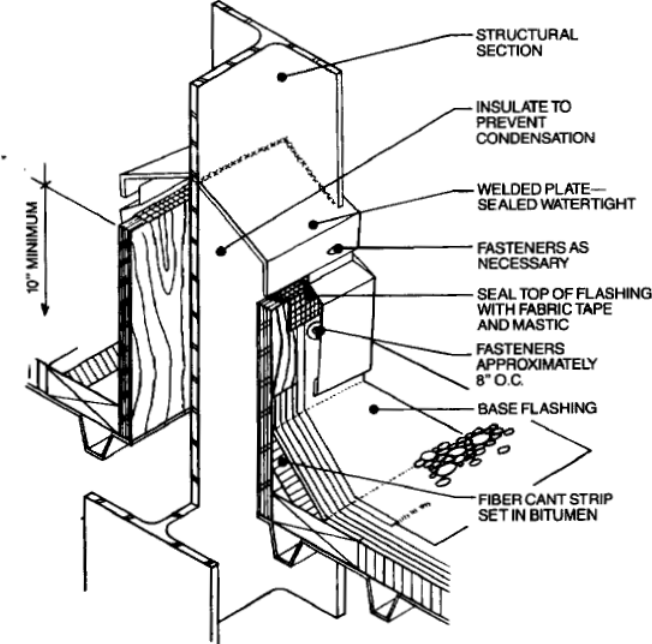

## Section C

---

### Unit Installation

---

1. WHEN UNITS ARE HANDLED, THE UNIT MANUFACTURER'S INSTRUCTIONS MUST BE CAREFULLY FOLLOWED. Units should not be moved over a roof membrane but should in some manner be lifted from the ground onto the curb or support framework.
2. **Seal** (to curbing): When setting the unit onto the curb, the installer should ensure that a sealing material is positioned between the unit and curb to provide a continuous watertight connection.  
(See Figure 6.)
3. The base of curb mounted units should extend beyond the curb. (See Figure 6.)
4. Installation should be in accordance with local code requirements.
5. Installation should provide for minimum blockage of snow.
6. Equipment mounting should be of heavy masonry or equivalent construction, or an auxiliary mounting platform shall be provided, to minimize vibration effects (see Paragraph 4.1.2 of AHRI Standard 270-95)" (formerly ARI Standard 270-95) Sound Rating of Outdoor Unitary Equipment."

**Figure 6**  
**Curb Detail For Rooftop**  
**Air Handling Units**

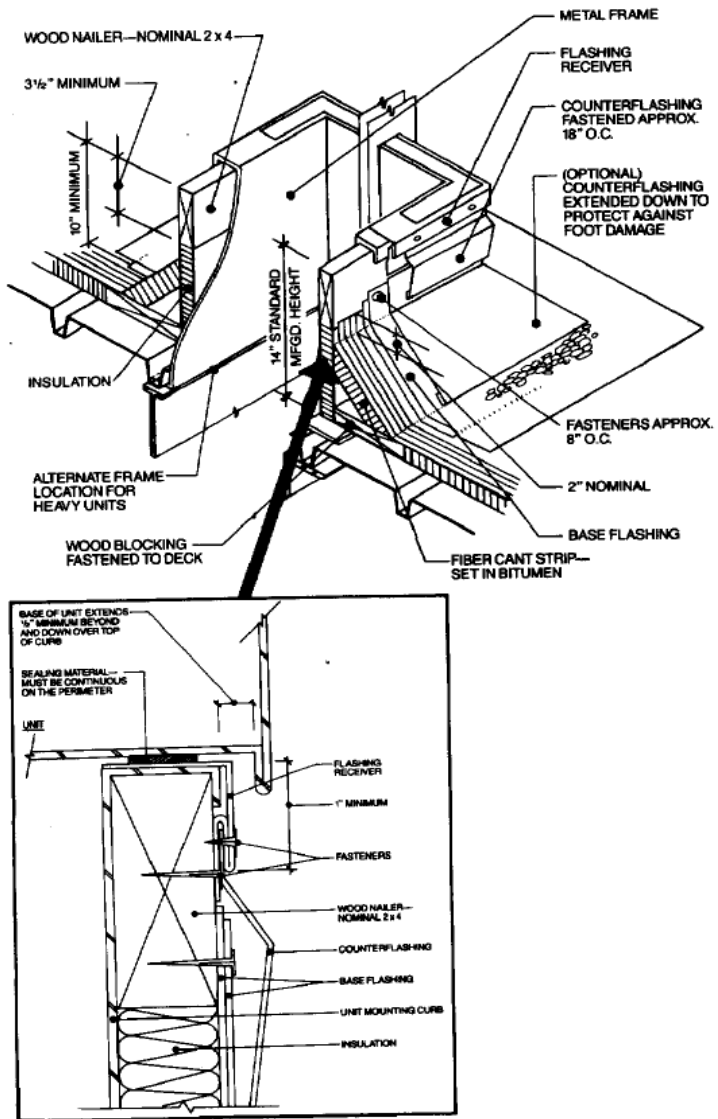

## Section D

---

### **External Connections**

---

#### Section D-1

---

### **Exterior Duct Closures and Connection to Equipment**

---

1. All ducts that are not watertight through the use of welded construction or protective shields and are exposed directly to weather and solar radiation should have secure watertight mechanical connections and receive exterior duct sealant treatment as defined in paragraph 2.
2. Exterior duct sealant treatment should consist of the supplemental application of a product or products marketed specifically as forming a positive air and watertight seal, bonding well to the metal involved, remaining watertight with metal movement and having a suitable service temperature range. If exposed to direct sunlight, it should also be ultraviolet ray and ozone resistant or should, after curing, be painted with a compatible coating that provides that resistance. The term "sealant" here is not limited to materials of adhesive or mastic nature but is inclusive of tapes and combinations of woven fabric strips and mastics. Asphalt based compounds are not recommended for sealing ductwork.
3. Unless otherwise prescribed by the equipment manufacturer, ducts should be attached to equipment with mechanical fastening supplemented with exterior duct sealant treatment as defined in paragraph 2. Typical connections are shown in Figure 7. The attachment method should accommodate disconnection if this is required for routine maintenance of the equipment.

4. Where vibration isolation material is required at the connection of ducts to equipment, such material should be watertight.
5. Roof penetrations by ducts should utilize counter-flashed curbs. Typical arrangements are shown in Figure 8.
6. All penetrations into ducts should be sealed watertight. Attachment of supports should use a minimum number of duct penetrations.
7. Duct systems should not be pressurized without sufficient time for curing of sealant systems. Follow sealant manufacturers recommendations for application of the sealant.
8. Adequate clearances between ducts and roof penetration openings should be provided.
9. Ducts should be supported to avoid transfer of duct weight across flexible connections.
10. Horizontal ducts should be pitched and provided with drainage outlets as illustrated (by the system designer).
11. Ducts should be installed at a height sufficient to install roofing and flashing. (*See Table 1.*)



# Figure 7

---

## Rooftop Duct Insulation

---

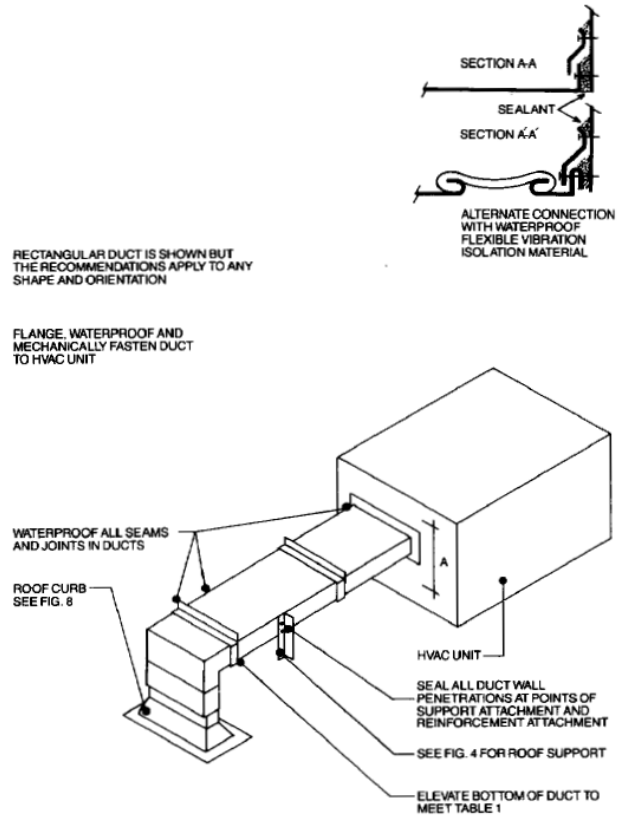
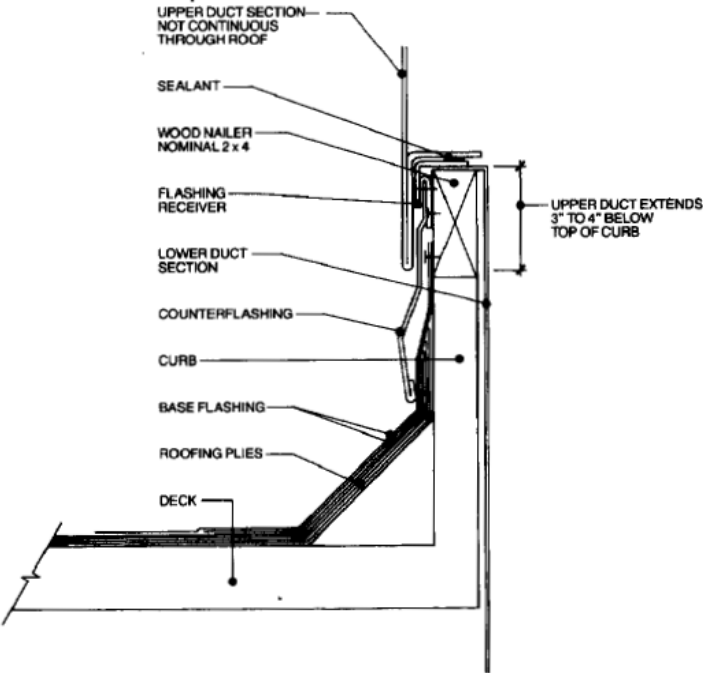

Figure 8

---

Duct Penetration of roof

---



## Section D-2

---

### **Electrical**

---

1. Whenever possible, electrical conduit should be run to the unit inside the roof curb.
2. Electrical conduit connections made to exposed junction boxes on units should be made on the bottom of the box. Installation should comply with local code requirements. The installation should be made watertight.
3. Where an external electrical junction box is not used, watertight fittings should be used at the panel joint. If electrical conduit passes through a hole in the panel, that joint should be made watertight.
4. Where electrical conduit passes through the building roof, the construction shown in Figure 9 should be used.
5. Installation should be in accordance with the NFPA "National Electrical Code."

## Section D-3

---

### Piping

---

1. Whenever possible, piping should be brought down through the unit and inside the roof curb.
2. Piping connections made through the side of units not designed to accommodate water entry should be protected by a sheet metal enclosure whenever possible. Piping should be brought into the bottom of the enclosure. Where a sheet metal enclosure is not used watertight fittings should be used. Installation should comply with local plumbing code requirements.
3. Where piping passes through the building roof, the construction shown in Figure 9 and 10 should be used.
4. Where piping is insulated, insulation should not be installed until after the flashing has been completed.

# Figure 9

---

## Conduit and Piping Through Roof Deck

---

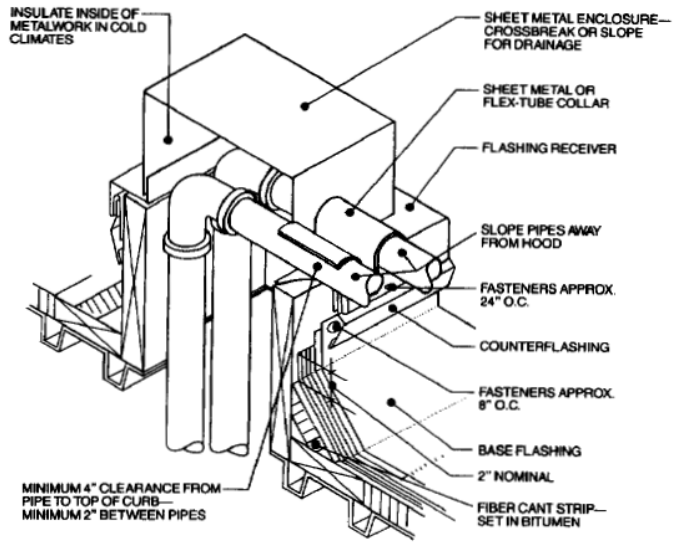
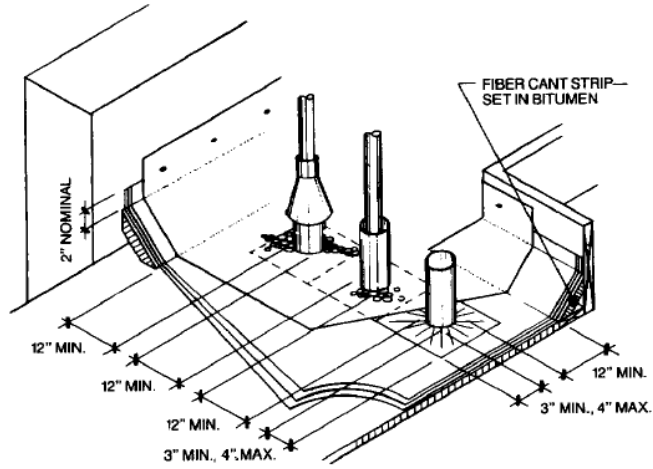

Figure 10

---

**Clearances For Multiple Pipes -  
Between Pipes and From Walls  
And Curbs**

---



---

**Drains**

---

If recommended by the manufacturer of the equipment, condensate drain lines should be provided with a "P" trap according to the manufacturer's specifications. If the condensate line passes through the building roof, the construction shown in Figure 9 should be used. Condensate lines should not drain onto the roof.

Some means of clean out for the "P" trap should be provided. If "P" trap is to be glued, a tee should be installed before the "P" trap.

## Section E

---

### **General Instructions**

---

#### Section E-1

---

### **Checklist for Equipment Installation and Service**

---

1. Exercise care in removing and replacing panels.
2. Replace all panels. Replace all panel fasteners and seals. Replace seals as required.
3. Connect all drain lines.
4. Report possible roofing and flashing damage observed during the servicing of equipment.
5. Remove debris.
6. Oil spills will damage the roof and should be immediately reported.
7. Servicemen should not place tools, equipment and materials on ductwork. Stay off of ducts and units.
8. Walk on walkways if provided.
9. Do not kick or damage cants or flashings.
10. Check unit for airtight fit on curb.



## Section E-2

---

### Flashings

---

1. Flashings are subjected to some of the most demanding conditions on the roof. The details included here establish the best known methods of installation for rooftop mounted equipment.
2. Never attach any roof flashing directly to rooftop unit.
3. For details not included in this manual, refer to the latest edition of The SMACNA Architectural Sheet Metal Manual.
4. Pitch pockets (also commonly referred to as pitch pans) are flanged, metal containers placed around columns or other roof penetrations. They are generally filled with asphalt plastic cement or pitch plastic cement and are top-poured with a compatible bitumen to seal the opening in the roof membrane created by the penetrating element. **Pitch pockets have not been shown in these details because, by the nature of their design, they are NOT continuously watertight and require frequent inspection and maintenance.** Though pitch pockets are frequently used as a cost compromise, their use is NOT recommended since better methods of sealing roof penetrations are available.